



Grain Handling

**DOUBLE-AUGER
GRAIN CARTS**

MODEL 1654

Serial Number B39880100 & Higher

Part No. 276935

Foreword



This symbol identifies important safety messages. When you see it, read the message that follows and be alert to the possibility of personal injury.

Remember, safety instructions stated in this manual are for your protection. Read them carefully and follow them closely when working around or using this machine.

Read and study this manual completely before attempting to operate this implement. Take this manual to the field for handy reference when operating, adjusting, or servicing your machine.

When referenced, “Right-Hand” (RH) and “Left-Hand” (LH) side of the machine are determined by standing behind the machine and facing in the direction of travel.



Product Information

When ordering parts or when requesting further information or assistance, always give the following information:

- Machine name
- Model number
- Serial number

All products manufactured by Unverferth Mfg. Co., Inc. are warranted to be free from material and workmanship defects for one full year from time of consumer delivery. Your local dealer will gladly assist you with any warranty questions.

Please fill out and retain this portion for your records.

Purchase Date _____ Model _____ Serial No. _____

Dealer _____ City _____

Dealer Contact _____ Phone _____



Serial Number Location

IMPORTANT

- *The information, specifications, and illustrations in the manual are based on information available at the time it was written. Due to continuing improvements in the design and manufacture of Parker products, all specifications and information contained herein are subject to change without notice.*

Table of Contents

Section I Safety

General Hazard Information	1-2
Safety Decals	1-3
Following Safety Instructions	1-6
Before Servicing or Operating	1-7
During Operation	1-8
Before Transporting	1-8
During Transport	1-8
Driveline Safety	1-9
Pressurized Oil	1-10
Preparing for Emergencies	1-11
Wearing Protective Equipment	1-11

Section II Set-Up

Set Up Checklist	2-2
Driveline Installation	2-3
Driveline Set-Up	2-3
Auger Set Up	2-6
7-Pin Connection & Auger Pivot Shipping Block Removal	2-6
Auger Spout Cylinder Stop Removal	2-7
Jack and Optional Hydraulic Jack	2-8
Jack	2-8
Install Hydraulic Jack (Optional)	2-8
Upper Side Ladder Extension	2-10
Wheel & Tire Set-Up	2-11
Tire Pressure	2-11
Wheel Nuts	2-11
SMV Emblem & SIS Decals	2-12
Video System (Optional)	2-12
Belt Engagement	2-13
Operational Check	2-14

FOR SCALE, TRACK, UHARVEST, ELECTRIC TARP, AND / OR WATER DELIVERY SYSTEM INFORMATION, PLEASE REFER TO THE INDIVIDUAL MANUALS.

Table of Contents

**Section III
Operation**

Operating Checklist 3-2

Preparing Tractor 3-3

Preparing Cart 3-4

 Hardware 3-4

 Pivot Pins 3-4

 Hitch 3-4

 Rear Drop Hitch (Optional) - For SN B44630100 & Higher 3-4

 Auger 3-5

 Hydraulic System 3-5

 Optional Hydraulic Brake System 3-5

 Tires/Wheels 3-5

Hitching to Tractor

 Drawbar Connection 3-6

 Jack Usage 3-7

 Optional Hydraulic Jack Usage 3-8

 Transport Chain Connection 3-9

 Hydraulic Connections 3-10

 Optional Implement Brake Connection 3-11

 Electrical Connections 3-12

 Towing 3-13

Auger Operation

 PTO-Driven Auger 3-14

 Vertical Auger Fold 3-16

 Auger Field Rest Position 3-17

 Auger Road Transport Position 3-18

 Upper Auger Rest Adjustments 3-19

 Auger Overload Procedure 3-20

Electric Over Hydraulic Operation (Optional)

 Electric/Hydraulic Connection 3-21

 Auger Fold & Spout Operation 3-22

 Flow Door Operation 3-23

 Auger Fold to Transport 3-23

Cart Loading Sequence 3-24

Vertical & Horizontal Cleanout Door Operation

 Closing Vertical Cleanout Door 3-25

 Opening Vertical Cleanout Door 3-26

 Horizontal Cleanout Door 3-27

In-Line Tandem 3-28

 Optional Implement Brake System for In-Line Tandem 3-28

Ladder Operation

 Side Ladder Operation - For SN B40560100 & Higher 3-29

 Rear Ladder Operation - For SN B44630100 & Higher 3-33

Rear Access Door Operation - For SN B44630100 & Higher 3-35

Rear Drop Hitch Operation (Optional) - For SN B44630100 & Higher

 Storage to Working Position 3-37

 Rear Hitch Connection 3-38

 Electrical Connection 3-39

 Rear Drop Hitch Adjustment 3-40

Video System (Optional) 3-41

Weather Guard Tarp 3-41

 Wireless Receiver and Control Box Location - For SN B43110100 & Higher 3-43

FOR SCALE, TRACK, UHARVEST, ELECTRIC TARP, AND / OR WATER DELIVERY SYSTEM INFORMATION, PLEASE REFER TO THE INDIVIDUAL MANUALS.

Table of Contents

**Section IV
Maintenance**

Lubrication - Cart..... 4-2

PTO Driveshaft Lubrication - Benzi PTO 4-6

PTO Driveshaft Lubrication - GKN Walterscheid PTO..... 4-7

Hydraulic System..... 4-8

 Purge Hydraulic System..... 4-8

Manual Override for Optional Electric Over Hydraulic System..... 4-9

Auger System

 Vertical Auger Height Check..... 4-12

 Vertical Auger Folding Linkage Adjustment..... 4-14

 Vertical Auger Timing..... 4-15

 Horizontal Auger..... 4-16

 Horizontal Auger Driveline Bearings..... 4-17

Baffle Adjustment..... 4-18

Horizontal Cleanout Door Adjustment..... 4-20

Belt Tightener Adjustment..... 4-22

V-Belt Alignment..... 4-24

 Split Tapered Bushings..... 4-25

Horizontal Auger Removal and Replacement - For SN B40450100 & Higher..... 4-26

Horizontal Auger Removal and Replacement - For SN B40450099 & Lower..... 4-32

Driveline Removal..... 4-37

Gearbox..... 4-37

Verify Telescoping PTO Shaft Length..... 4-38

PTO Shaft Length Adjustment..... 4-40

PTO Shaft & Clutch - Benzi PTO..... 4-41

PTO Shaft & Clutch - GKN Walterscheid PTO..... 4-43

Wheel, Hub and Spindle Disassembly and Assembly..... 4-45

Wheels & Tires

 Wheel Nut Torque Requirements..... 4-47

 Tire Pressure..... 4-48

 Tire Warranty..... 4-50

Bleeding Procedure for Braking System..... 4-51

Hydraulic Jack Cylinder Replacement..... 4-52

Seasonal Storage..... 4-54

Troubleshooting..... 4-55

Auger Switch Troubleshooting..... 4-57

Tarp Troubleshooting Inspection & Maintenance..... 4-58

Electrical System Diagram..... 4-59

Electrical Diagram..... 4-61

Electrical Over Hydraulic (EOH) System Schematic..... 4-71

Optional Electric Over Hydraulic Valve Electric Schematic 5 Spool..... 4-72

Electrical System Schematic - Optional Wireless Electric Tarp - For SN B43110100 & Higher..... 4-73

Electrical System Schematic - Optional Electric Tarp - For SN B43110099 & Lower..... 4-74

Braking System Schematic..... 4-75

Torque Chart - Hardware Grade 5..... 4-76

Torque Chart - Hardware Grade 8..... 4-77

Hydraulic Fittings - Torque and Installation..... 4-78

FOR SCALE, TRACK, UHARVEST, ELECTRIC TARP, AND / OR WATER DELIVERY SYSTEM INFORMATION, PLEASE REFER TO THE INDIVIDUAL MANUALS.

Table of Contents

**Section V
Parts**

Please visit www.unverferth.com/parts/ for the most current parts listing.

Decals	5-2
Touch-Up Paint	5-5
Front End Components	5-6
Side Ladder Components - SN B41030100 & Higher	5-8
Rear Ladder Components - SN B44630100 & Higher	5-10
Rear Access Door Components - SN B44630100 & Higher	5-11
Hopper Cross Brace & Cleanout Door Components	5-12
Sideboards - SN B43120100 & Higher	5-14
Sideboards - SN B43120099 & Lower	5-16
Tandem Axle Components	5-18
Tandem Hub Components	5-20
Tandem Wheels & Tires	5-21
Tandem Grease Bank Assembly	5-21
Brake Components (Optional)	5-22
Track Axle Components	5-24
Track Panel Kit Components	5-25
Hopper Flow Door Components	5-26
Front and Rear Flow Door Components	5-28
Flow Door Indicator Assembly	5-30
Rear Runner Brace Components	5-32
Vertical Auger Flighting Components	5-34
Horizontal Auger Components - SN B40450100 & Higher	5-36
Horizontal Auger Components - SN B40450100 & Lower	5-38
Auger Fold Linkage Components	5-40
Downspout Components	5-44
Rotating Spout Components	5-46
Optional Spout Rotate Switch Assembly Components	5-48

FOR SCALE, TRACK, UHARVEST, ELECTRIC TARP, AND / OR WATER DELIVERY SYSTEM INFORMATION, PLEASE REFER TO THE INDIVIDUAL MANUALS.

(Continued on next page)

Table of Contents

**Section V
Parts (Continued)**

Please visit www.unverferth.com/parts/ for the most current parts listing.

Lower Auger Cleanout Door, Covers & Rest Components.....	5-50
Lower Auger Linkage Components.....	5-52
Lower Auger Idler Assembly Components.....	5-54
Lower Auger Retainer Assembly Components.....	5-56
Cut Out Clutch PTO Assembly - Benzi.....	5-58
Cut Out Clutch Assembly - Benzi.....	5-59
Cut Out Clutch PTO Assembly - Walterscheid.....	5-60
Cut Out Clutch Assembly - Walterscheid.....	5-61
Gearbox Components.....	5-62
EOH Valve Assembly Components - Optional.....	5-64
EOH Valve Functions and Wire Locations - Optional.....	5-66
EOH Tractor Circuit Hydraulic Components - Optional.....	5-67
EOH Spout Rotate Option and Tilt Hydraulic Components.....	5-68
Auger Pivot Hydraulic Components.....	5-70
Auger Fold Hydraulic Components.....	5-71
Flow Door Circuit Hydraulic Components.....	5-72
Cylinders.....	5-74
Hopper Rear Electrical Components.....	5-76
Electrical Components.....	5-78
End Caps, Tarp Bows & Mounting Brackets.....	5-80
Weather Guard Tarp.....	5-82
Hydraulic Jack - Kit #296289B (Optional).....	5-84
Rear Drop Hitch (Optional) - SN B44630100 & Higher.....	5-85
Video System (Optional).....	5-86

FOR SCALE, TRACK, UHARVEST, ELECTRIC TARP, AND / OR WATER DELIVERY SYSTEM INFORMATION, PLEASE REFER TO THE INDIVIDUAL MANUALS.

Section I Safety

General Hazard Information	1-2
Safety Decals	1-3
Following Safety Instructions	1-6
Before Servicing or Operating	1-7
During Operation	1-8
Before Transporting	1-8
During Transport.....	1-8
Driveline Safety.....	1-9
Pressurized Oil	1-10
Preparing for Emergencies.....	1-11
Wearing Protective Equipment	1-11

General Hazard Information

No accident-prevention program can be successful without the wholehearted cooperation of the person who is directly responsible for the operation of the equipment.

A large number of accidents can be prevented only by the operator anticipating the result before the accident is caused and doing something about it. No power-driven equipment, whether it be transportation or processing, whether it be on the highway, in the field, or in the industrial plant, can be safer than the person who is at the controls. If accidents are to be prevented--and they can be prevented--it will be done by the operators who accept the full measure of their responsibility.

It is true that the designer, the manufacturer, and the safety engineer can help; and they will help, but their combined efforts can be wiped out by a single careless act of the operator.

It is said that, "the best kind of a safety device is a careful operator." We, at Unverferth Mfg. Co., Inc. ask that you be that kind of operator.



REMEMBER:
THINK SAFETY
A CAREFUL OPERATOR IS THE
BEST INSURANCE AGAINST AN
ACCIDENT!

SIGNAL WORDS



INDICATES AN EXTREMELY HAZARDOUS SITUATION OR ACTION THAT WILL RESULT IN SERIOUS INJURY OR DEATH.



INDICATES A HAZARDOUS SITUATION OR ACTION THAT COULD RESULT IN SERIOUS INJURY OR DEATH.



INDICATES AN UNSAFE SITUATION OR ACTION THAT MAY RESULT IN PERSONAL INJURY.



Is used for instruction on operating, adjusting, or servicing a machine.

Safety Decals

WARNING

- REPLACE LOST, DAMAGED, PAINTED, OR UNREADABLE DECALS IMMEDIATELY. IF PARTS THAT HAVE DECALS ARE REPLACED, ALSO MAKE SURE TO INSTALL NEW DECALS. THESE DECALS INFORM AND REMIND THE OPERATOR WITH OPERATIONAL INFORMATION AND SAFETY MESSAGES.

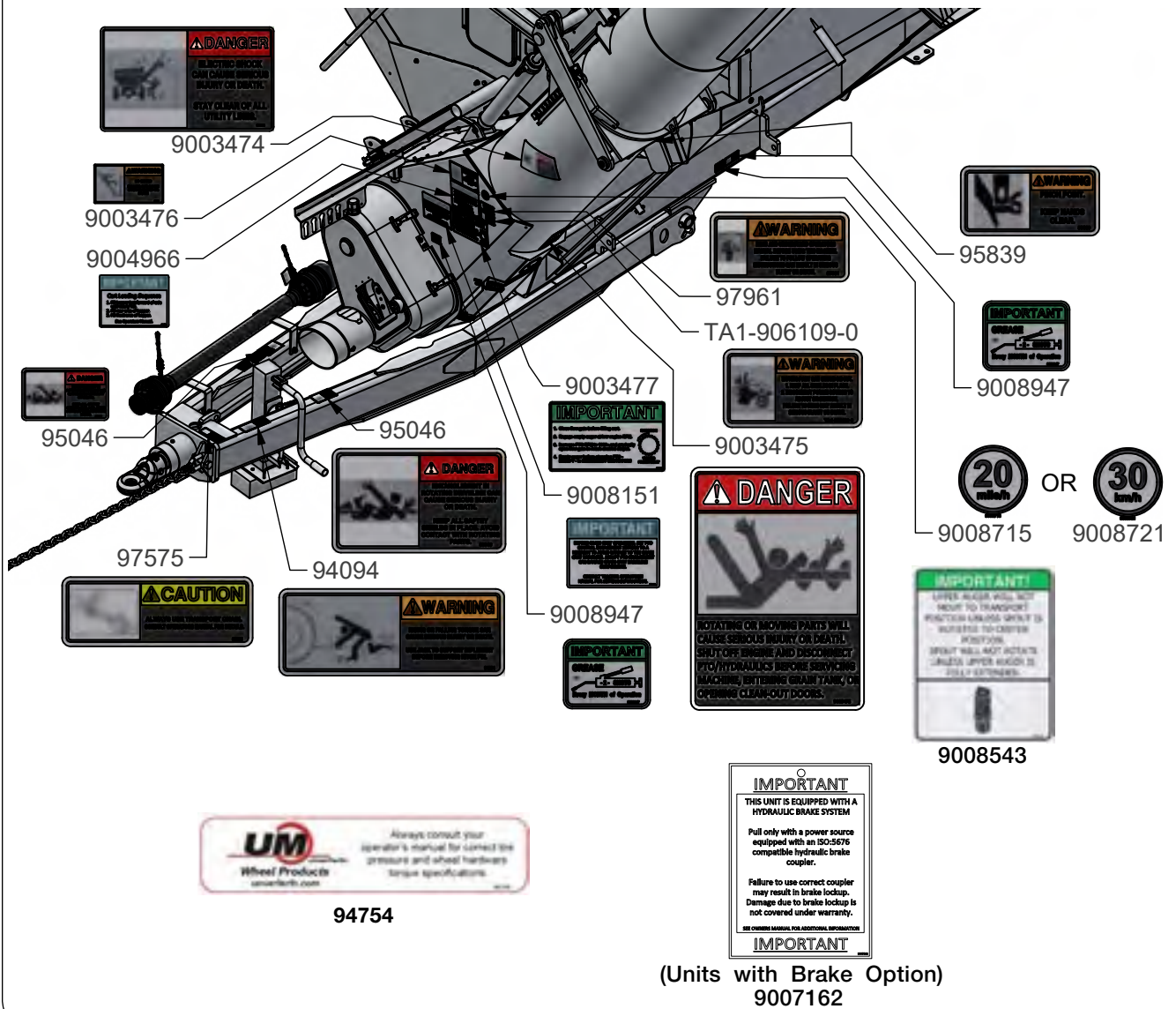

Safety Decals (continued)

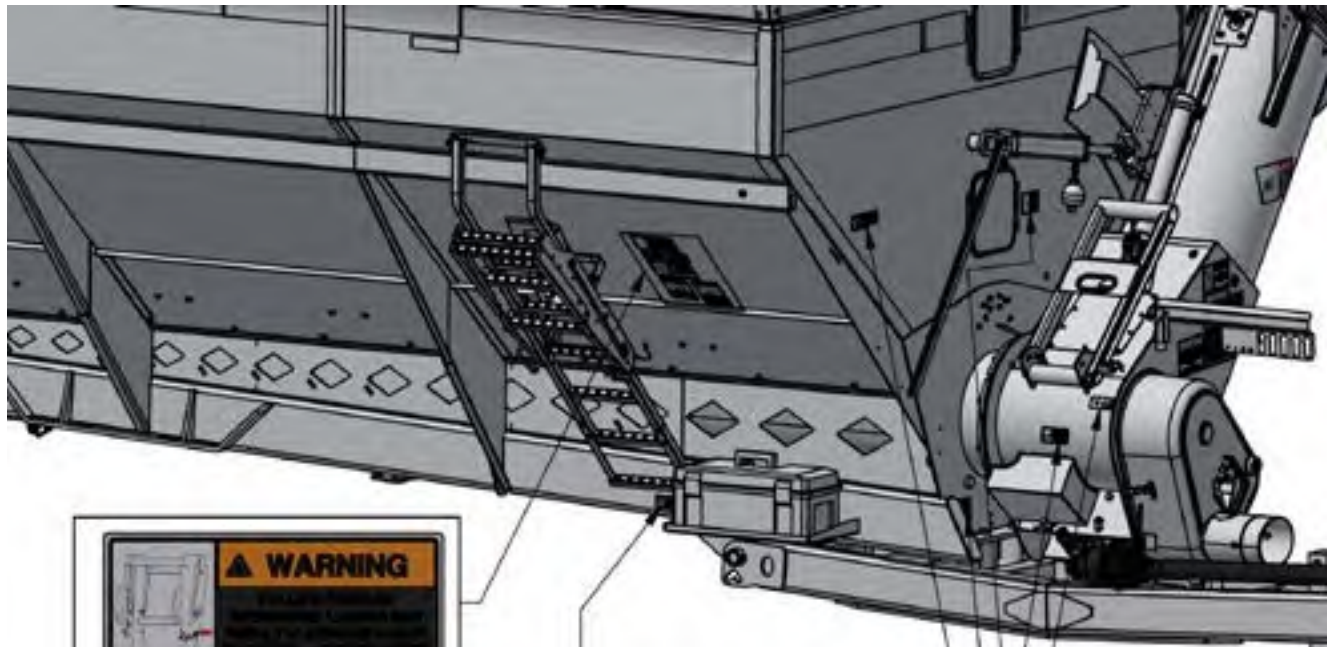

9009168

95839

95008

9003476

9003478

9003475

95839

9008947

98229

9008947

95839

95445

900024

9005971

WARNING

TO PREVENT SERIOUS INJURY OR DEATH:

NEVER ADJUST OR SERVICE SUSPENSION SYSTEM WHEN UNIT IS LOADED.



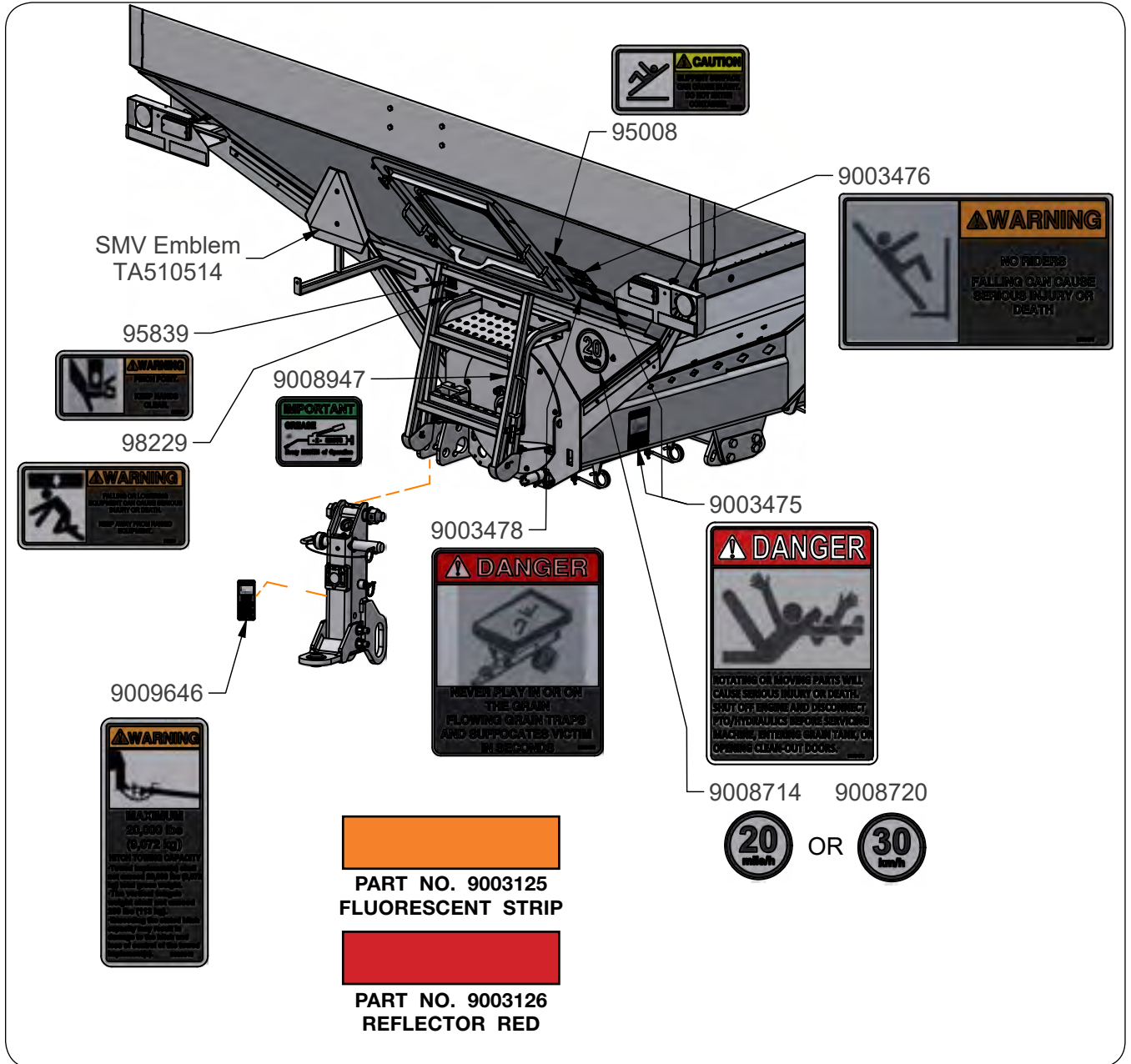

SEE OPERATOR MANUAL FOR SAFETY PROCEDURES AND WARNINGS.

PART NO. 9003127 REFLECTOR AMBER

Safety Decals (continued)



Following Safety Instructions

- Read and understand this operator's manual before operating. 
- All machinery should be operated only by trained and authorized personnel.
- To prevent machine damage, use only attachments and service parts approved by the manufacturer.
- Always shut tractor engine off and remove key before servicing. 
- Avoid personal attire such as loose fitting clothing, shoestrings, drawstrings, pants cuffs, long hair, etc., that may become entangled in moving parts.
- Do not allow anyone to ride on the implement. Make sure everyone is clear before operating machine or towing vehicle. 
- Never attempt to operate implement unless you are in the driver's seat.
- Never enter a cart containing grain. Flowing grain traps and suffocates victims in seconds. 
- This unit may be equipped with a hydraulic brake system. Pull only with a power source equipped with an ISO:5676 compatible hydraulic brake coupler. Failure to use correct coupler may result in brake lockup. Damage due to brake lockup is not covered under warranty.

Before Servicing or Operating

- Avoid working under an implement; however, if it becomes absolutely unavoidable, make sure the implement is safely blocked. 

- Ensure that all applicable safety decals are installed and legible.

- When working around the implement, be careful not to be cut by sharp edges.

- To prevent personal injury or death, always ensure that there are people who remain outside the cart to assist the person working inside, and that all safe workplace practices are followed. There is restricted mobility and limited exit paths when working inside the implement.

- Secure drawbar pin with safety lock and lock tractor drawbar in fixed position.

- Explosive separation of a tire and rim can cause serious injury or death. Only properly trained personnel should attempt to service a tire and wheel assembly.

- Verify that all safety shields are in place and properly secured. 

- Add sufficient ballast to tractor to maintain steering and braking control at all times. Do not exceed tractor's lift capacity or ballast capacity.

- Do not stand between towing vehicle and implement during hitching. 

- Always make certain everyone and everything is clear of the machine before beginning operation.

During Operation

- Regulate speed to working conditions. Maintain complete control at all times.
- Never service or lubricate equipment when in operation.
- Keep away from overhead power lines. Electrical shock can cause serious injury or death.
- Use extreme care when operating close to ditches, fences, or on hillsides.
- Do not leave towing vehicle unattended with engine running.



Before Transporting

- Secure transport chain to towing vehicle before transporting. DO NOT transport without chain.
- Check for proper function of all available transport lights. Make sure that all reflectors are clean and in place on machine. Make sure the SMV emblem and SIS decals are visible to approaching traffic.
- Make sure auger is folded and vertical auger assembly is positioned in its narrowest configuration.
- This implement may not be equipped with brakes. Ensure that the towing vehicle has adequate weight and braking capacity to tow this implement.

During Transport

- Comply with all laws governing highway safety when moving machinery.
- Use transport lights as required by all laws to adequately warn operators of other vehicles.
- Regulate speed to road conditions and maintain complete control.
- Maximum transport speed of this implement should never exceed 20 m.p.h. as indicated on the machine. Maximum transport speed of any combination of implements must not exceed the lowest specified speed of the implements in combination. Do not exceed 10 m.p.h. during off-highway travel.
- Slow down before making sharp turns to avoid tipping. Drive slowly over rough ground and side slopes.
- Do not transport grain cart on roads while loaded.
- It is probable that this implement is taller, wider and longer than the towing vehicle. Become aware of and avoid all obstacles and hazards in the travel path of the equipment, such as power lines, ditches, etc.

Driveline Safety

- Do not allow children near equipment that is running or engaged.

- Do not exceed 1000 r.p.m. PTO speed.
- Disengage the PTO, stop the tractor engine, and remove key from ignition before making inspections, or performing maintenance and repairs.
- Inspect the driveline, quick disconnect, overload shear-bolt limiter or clutch, and shielding often. Repair immediately. Use replacement parts and attaching hardware equivalent to the original equipment. Only alterations described in this manual for overall length adjustment are allowed. Any other alteration is prohibited.
- Avoid excessively long hardware or exposed and protruding parts which can snag and cause entanglement.
- Lubricate the driveline as recommended in the MAINTENANCE section.
- Keep hoses, wiring, ropes, etc. from dangling too close to the driveline.
- Install driveline and shields according to recommended lengths and attaching methods with recommended hardware. The driveline shield should rotate independently a full rotation and telescope freely. The retaining chain must be secured to the implement safety shield.
- Adjust drawbar to height and length recommended in the OPERATION section.
- Use caution when turning to avoid contact between tractor tires and driveline.
- Check the length of the telescoping members to insure the driveline will not bottom out or separate when turning and/or going over rough terrain. Refer to “PTO Shaft Length Adjustment” in MAINTENANCE section.
- Proper extended and collapsed lengths of the telescoping PTO shaft must be verified before first operation with each and every tractor. If the extended length of the PTO shaft is insufficient, it may become uncoupled during operation and cause serious injury or death from contact with uncontrolled flailing of PTO shaft assembly components. Refer to “PTO Shaft Length Adjustment” in MAINTENANCE section.

Pressurized Oil

- Relieve the hydraulic system of all pressure before adjusting or servicing. See hydraulic power unit manual for procedure to relieve pressure.

- High-pressure fluids can penetrate the skin and cause serious injury or death. Leaks of high-pressure fluids may not be visible. Use cardboard or wood to detect leaks in the hydraulic system. Seek medical treatment immediately if injured by high-pressure fluids. 

- Accumulators used in this hydraulic system can retain fluid under pressure even after tractor hydraulic valve is placed in FLOAT. See tractor operators manual for procedure to relieve pressure.

- Hydraulic system must be purged of air before operating to prevent serious injury or death.

- Do not bend or strike high-pressure lines. Do not install bent or damaged tubes or hoses.

- Repair all oil leaks. Leaks can cause fires, personal injury, and environmental damage.

- Route hoses and lines carefully to prevent premature failure due to kinking and rubbing against other parts. Make sure that all clamps, guards and shields are installed correctly.

- Check hydraulic hoses and tubes carefully. Replace components as necessary if any of the following conditions are found:
 - End fittings damaged, displaced, or leaking.
 - Outer covering chafed/cut or wire reinforcing exposed.
 - Outer covering ballooning locally.
 - Evidence of kinking or crushing of the flexible part of a hose.

Preparing for Emergencies

- Keep a first aid kit and properly rated fire extinguisher nearby.



- Keep emergency numbers for fire, rescue, and poison control personnel near the phone.



Wearing Protective Equipment

- Wear clothing and personal protective equipment appropriate for the job.



- Wear steel-toed shoes when operating.



- Wear hearing protection when exposed to loud noises.



- Do not wear additional hearing impairing devices such as radio headphones, etc.



Notes

Section II Set-Up

Set Up Checklist.....	2-2
Driveline Installation.....	2-3
Driveline Set-Up.....	2-3
Auger Set Up.....	2-6
7-Pin Connection & Auger Pivot Shipping Block Removal.....	2-6
Auger Spout Cylinder Stop Removal.....	2-7
Jack and Optional Hydraulic Jack	2-8
Jack.....	2-8
Install Hydraulic Jack (Optional).....	2-8
Upper Side Ladder Extension	2-10
Wheel & Tire Set-Up	2-11
Tire Pressure	2-11
Wheel Nuts.....	2-11
SMV Emblem & SIS Decals	2-12
Video System (Optional).....	2-12
Belt Engagement.....	2-13
Operational Check.....	2-14

FOR SCALE, TRACK, UHARVEST, ELECTRIC TARP, AND / OR WATER DELIVERY SYSTEM INFORMATION, PLEASE REFER TO THE INDIVIDUAL MANUALS.

Set Up Checklist

After the cart has been completely assembled, use the following checklist and inspect the cart. Check off each item as it is found satisfactory or after proper adjustment is made.

- Set or Calibrate tractor PTO control engagement to MINIMUM setting. Refer to tractor operator's manual for setting information.
- Remove auger spout cylinder stop.
- Remove PTO from shipping brackets, install onto gearbox input shaft and set in PTO holder. Remove PTO shipping brackets.
- Move upper ladder extension from shipping to operating position. See "Upper Side Ladder Extension" in this section.
- Torque wheel nuts as specified in MAINTENANCE section.
- Check tire pressure and inflate tires as needed to specified air pressure. See "Tire Pressure" in MAINTENANCE section. (If applicable)
- Ensure optional hydraulic brakes are bled and function properly. See "Brake Bleeding Procedure For Braking System (Optional)" in MAINTENANCE section. (If applicable)
- Verify track has been aligned and is properly conditioned. Refer to 50" / 42" Equalizer Track manual (267909) or 36" x 148" Hydraulic Tension Track manual (267997) MAINTENANCE section for alignment information. (If applicable)
- Lubricate all grease fittings and check gearbox oil level.
- Inspect cleanout door assembly for proper adjustment, refer to "Vertical & Horizontal Clean-Out Door Operation" in the OPERATION section.
- Verify all safety decals are correctly located and legible. Replace if damaged.
- Verify all reflective decals are correctly located.
- Check SMV decal and SIS decals are in place, clean and visible.
- Verify transport lights are working properly.
- Verify PTO length, see "Verify Telescoping PTO Shaft Length" in MAINTENANCE section.
- Align and properly tension belts. See "Belt Tightener Adjustment" and "V-Belt Alignment" in MAINTENANCE section.
- Ensure screens over horizontal auger are in place and properly secured.
- Ensure transport chain on the grain cart is sized according to the weight that is being towed. Refer to "Transport Chain Connection" in OPERATION section for complete transport chain instructions.
- Install transport chains and torque hardware to specification. See "Transport Chain Connection" in OPERATION section.
- Paint all parts scratched in shipment.
- Test run the augers. See "Auger Operation" in OPERATION section.
- Check hydraulics for leaks and check hose routing.

Driveline Installation

Driveline Set Up

DANGER

- ENTANGLEMENT WITH THE DRIVELINE WILL CAUSE SERIOUS INJURY OR DEATH. KEEP ALL GUARDS AND SHIELDS IN GOOD CONDITION AND PROPERLY INSTALLED AT ALL TIMES. AVOID PERSONAL ATTIRE SUCH AS LOOSE FITTING CLOTHING, SHOE STRINGS, DRAWSTRINGS, PANTS CUFFS, LONG HAIR, ETC. THAT CAN BECOME EN-TANGLED IN A ROTATING DRIVELINE.

WARNING

- TO PREVENT PERSONAL INJURY OR DEATH, ALWAYS ENSURE THAT THERE ARE PEOPLE WHO REMAIN OUTSIDE THE CART TO ASSIST THE PERSON WORKING INSIDE AND THAT ALL SAFE WORKPLACE PRACTICES ARE FOLLOWED. THERE IS RESTRICTED MOBILITY AND LIMITED EXIT PATHS WHEN WORKING INSIDE THE IMPLEMENT.
 - TIPPING OR MOVEMENT OF THE MACHINE CAN CAUSE SERIOUS INJURY OR DEATH. BE SURE MACHINE IS SECURELY BLOCKED.
 - EYE PROTECTION AND OTHER APPROPRIATE PERSONAL PROTECTIVE EQUIPMENT MUST BE WORN WHILE SERVICING IMPLEMENT.
 - KEEP HANDS CLEAR OF PINCH POINT AREAS.
 - FALLING OBJECTS CAN CAUSE SERIOUS INJURY OR DEATH. DO NOT WORK UNDER THE MACHINE AT ANY TIME WHILE BEING HOISTED. BE SURE ALL LIFTING DEVICES AND SUPPORTS ARE RATED FOR THE LOADS BEING HOISTED. THESE ASSEMBLY INSTRUCTIONS WILL REQUIRE SAFE LIFTING DEVICES UP TO 30,000 LBS. SPECIFIC LOAD RATINGS FOR INDIVIDUAL LOADS WILL BE GIVEN AT THE APPROPRIATE TIME IN THE INSTRUCTIONS.
1. Remove PTO assembly from the tongue. Remove clamp cone/socket head bolt from torque cut-out clutch.
 2. Clean and grease the Implement Gearbox splined shaft. Gearbox shaft guard has access doors for installing and removing of driveline.
 3. Attach PTO onto the gearbox input splined shaft and use the PTO holder as shown below. (Fig. 2-1)

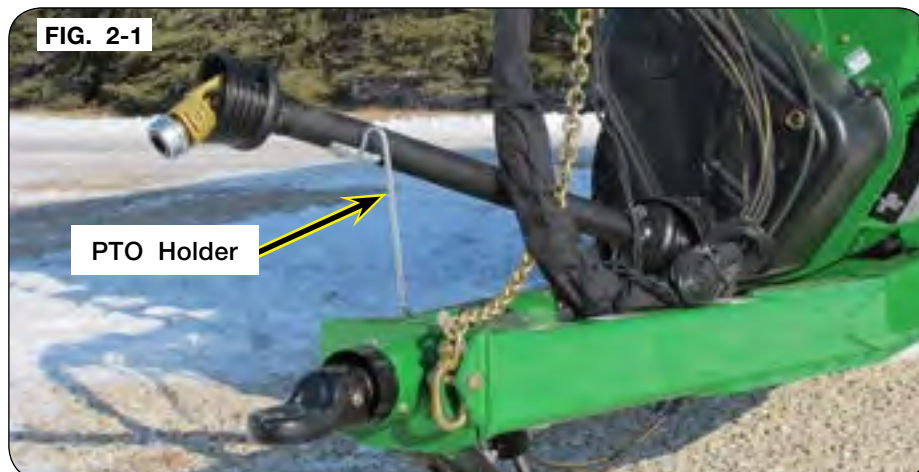

Driveline Install (continued)

Driveline Set Up (continued)

4. Remove the PTO brackets on the tongue, before operating the auger pivot or when connecting the driveline assembly to the tractor. Keep PTO brackets for seasonal storage. Refer to “Seasonal Storage” in MAINTENANCE section. (Fig. 2-2)

IMPORTANT

- *PTO assembly and PTO brackets must be removed before operating the auger pivot or when connecting the driveline assembly to the tractor. Failure to remove PTO assembly and PTO brackets will result in damage to the PTO assembly, tongue, auger and tractor.*

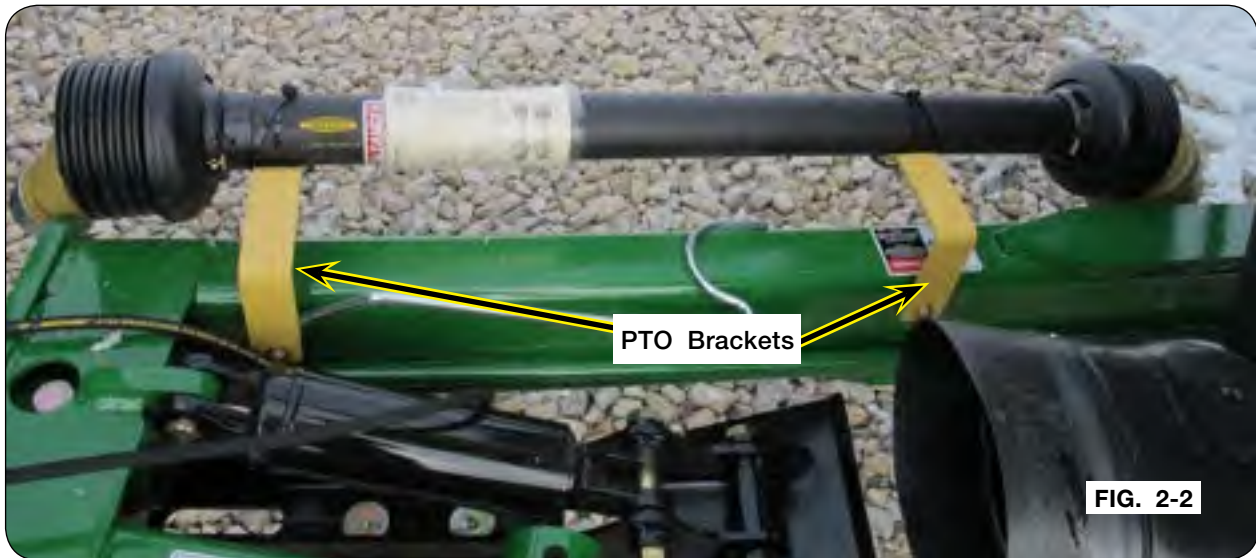

Driveline Install (continued)

Driveline Set Up (continued)

5. Engage PTO drive shaft onto implement PTO shaft until retaining groove of implement PTO shaft aligns with clamping cone/socket head bolt hole.
6. For Benzi clutch, insert socket head bolt into lock washer, collar threaded hole, and threaded insert, hand tighten. (Figs. 2-3 and 2-4)

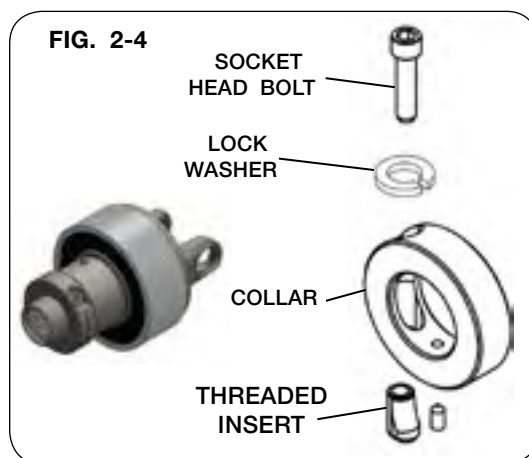

7. For GKN Walterscheid clutch, insert clamping cone into threaded hole, hand tighten. (Fig. 2-5)
8. Torque clamping cone/socket head bolt to 75 ft.-lb. (Figs. 2-4 and 2-5)

NOTE: See MAINTENANCE section - Driveline Removal - for further instructions.

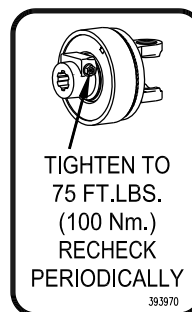
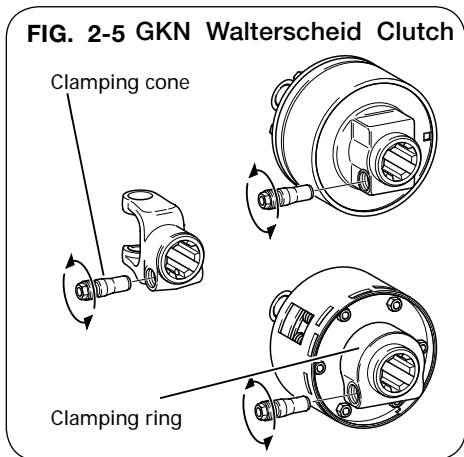

Auger Set Up

⚠ WARNING

- HIGH-PRESSURE FLUIDS CAN PENETRATE THE SKIN AND CAUSE SERIOUS INJURY OR DEATH. LEAKS OF HIGH-PRESSURE FLUIDS MAY NOT BE VISIBLE. USE CARDBOARD OR WOOD TO DETECT LEAKS IN THE HYDRAULIC SYSTEM. SEEK MEDICAL TREATMENT IMMEDIATELY IF INJURED BY HIGH-PRESSURE FLUIDS.
- RELIEVE THE HYDRAULIC SYSTEM OF ALL PRESSURE BEFORE ADJUSTING OR SERVICING. SEE THE HYDRAULIC POWER UNIT OPERATOR'S MANUAL FOR PROPER PROCEDURES.
- HYDRAULIC SYSTEM MUST BE PURGED OF AIR BEFORE OPERATING TO PREVENT SERIOUS INJURY OR DEATH.
- FALLING OR LOWERING EQUIPMENT CAN CAUSE SERIOUS INJURY OR DEATH. KEEP EVERYONE AWAY FROM EQUIPMENT WHEN SUSPENDED, RAISING, OR LOWERING.
- EYE PROTECTION AND OTHER APPROPRIATE PERSONAL PROTECTIVE EQUIPMENT MUST BE WORN WHILE SERVICING IMPLEMENT.
- KEEP HANDS CLEAR OF PINCH POINT AREAS.

7-Pin Connection & Auger Pivot Slide Shipping Block Removal

1. Close the vertical cleanout door.
2. Remove the PTO assembly from the tongue. Refer to "Driveline Install" in this section.
3. Hitch cart to tractor. Refer to "Hitching to Tractor" in the OPERATION section.
4. Park the empty cart on a firm, level surface. Block the machine to keep it from moving. Set the tractor's parking brake.
5. Attach the 7-pin connector to tractor. (FIG. 2-6)

NOTE: Auger hydraulic functions will not operate without power and ground via the 7-pin connector.

6. Use tractor SCV to pivot auger up.
7. Shut-off the engine and remove the ignition key.
8. Remove and discard the wood block from the auger pivot. (FIG. 2-7)
9. Restart engine and cycle auger pivot all the way up and down to ensure movement is free.
10. Check all hoses and cylinders for signs of leakage. Hoses should not be kinked, twisted or rubbing against sharp edges. Re-route hoses as necessary. Refer to SAFETY section for additional information.

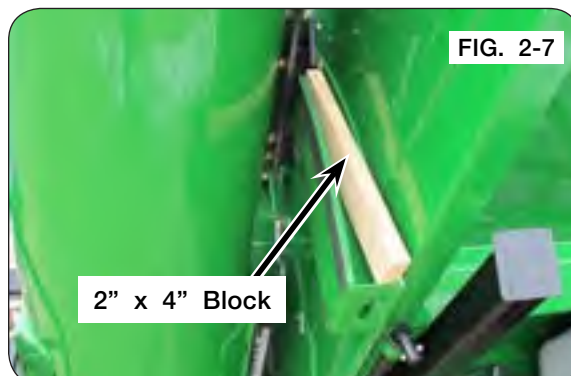
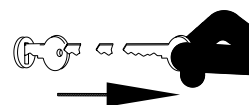
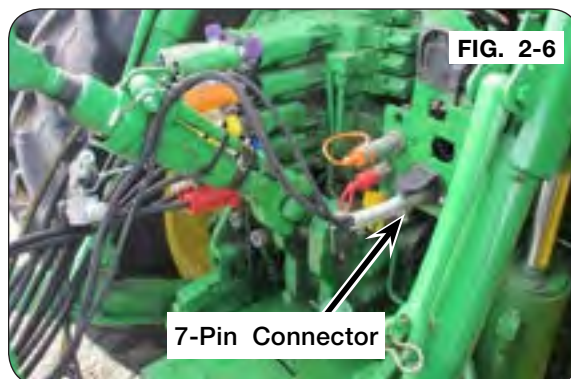

Auger Set Up (continued)

Auger Spout Cylinder Stop Removal

1. Extend spout cylinder before removing the shipping stop. (Figs. 2-8 and 2-9)
2. Support spout to prevent movement while removing the shipping stop from the spout tilt cylinder. (Figs. 2-8 and 2-9)

IMPORTANT

- *Cylinder stop must be removed before operating the auger spout. Failure to remove stop will result in damage to the cylinder and spout.*



Jack & Optional Hydraulic Jack Set Up

Jack

WARNING

- UNHITCHING A LOADED CART CAN CAUSE SERIOUS INJURY OR DEATH DUE TO TONGUE RISING OR FALLING. ALWAYS HAVE A LOADED CART ATTACHED TO A TRACTOR. THE JACK IS INTENDED TO SUPPORT AN EMPTY CART ONLY.

Attach jack to left-inside frame using pin and hair pin. (FIG. 2-10) Pivot the jack 90 degrees and reinstall pin for field use.

FIG. 2-10

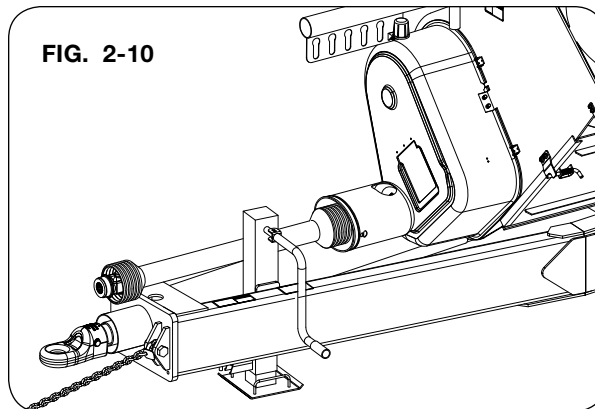

Install Hydraulic Jack (Optional)

1. Park the unit on a firm, level surface. Block the machine to keep it from moving. Set the vehicle parking brake, shut off the engine and remove the ignition key and disconnect the PTO shaft from the tractor.
2. Assemble hoses (9006068) and fittings to cylinder (9009047) as shown in figure 2-11. The valve needs to be attached to the hose on the base end of the cylinder. Assemble the fittings on the cylinder so they face each other, then store the hydraulic hoses on the hose caddy.



FIG. 2-11

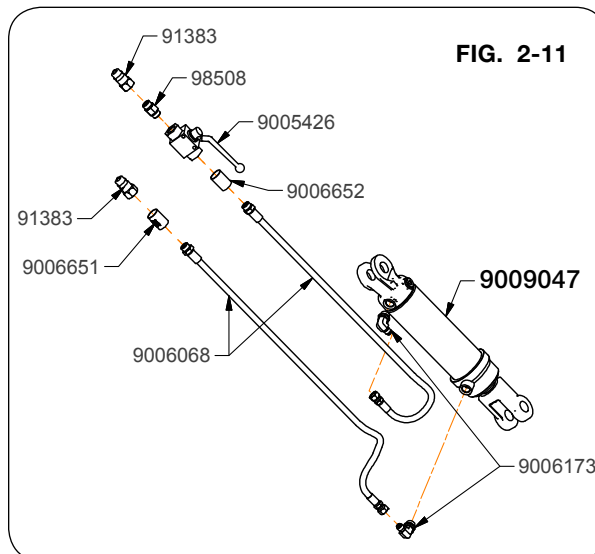

Jack & Optional Hydraulic Jack Set Up (continued)

Install Hydraulic Jack (Optional) (continued)

⚠ WARNING

- KEEP HANDS CLEAR OF PINCH POINT AREAS.

3. Assemble the cylinder (9009047) and jack foot (271723B) to the jack weldment (271712B) as shown in figure 2-12 using 1”-8UNC x 7” capscrews (9390-197) and 1”-8UNC locknuts (92199).

NOTE: Ensure all jack leg weldment (271712B) joints can pivot freely, especially jack foot (271723B).

4. Tighten 1” hardware to jack leg weldment and allow the cylinder and jack foot to freely pivot. (Fig. 2-12)

5. Attach the jack weldment (271712B) to the lower tabs behind the hitch plate on the tongue, shown in figure 2-13 using 1”-8UNC x 7” cap-screws (9390-197) and 1”-8UNC locknuts (92199).

6. Tighten 1” hardware to jack leg weldment and allow the joint to pivot. (Fig. 2-13)

7. Align the base end of the cylinder with the lug on the top of the tongue and assemble the cylinder pin (272587) and snap rings (91192) shown in figure 2-14.

NOTE: Refer to “Optional Hydraulic Jack Usage” in the OPERATION section for additional information.

8. Purge air from system. See “Purge Hydraulic System” in the MAINTENANCE section for procedure.

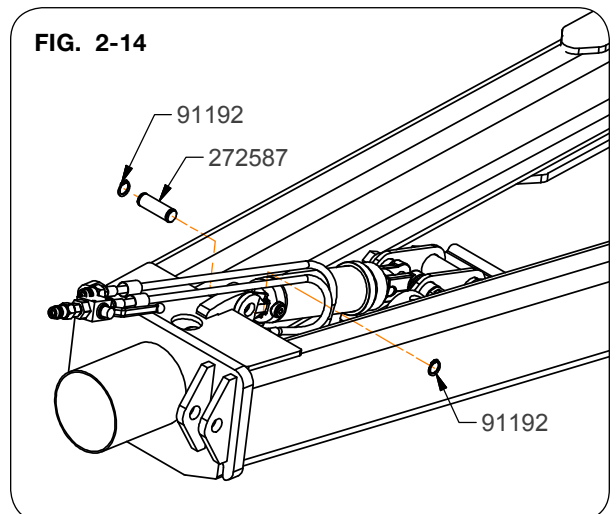
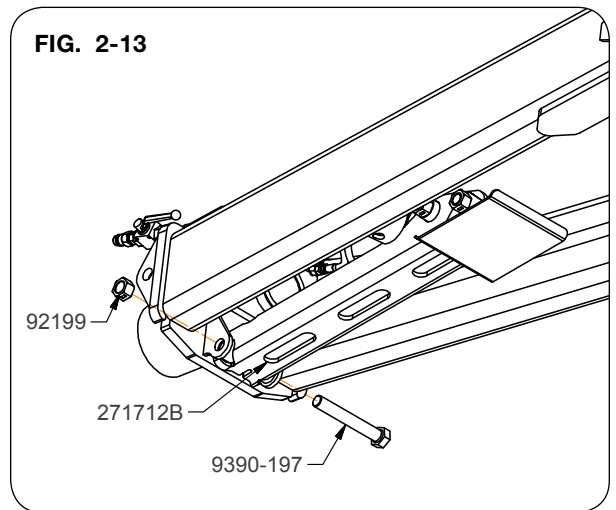
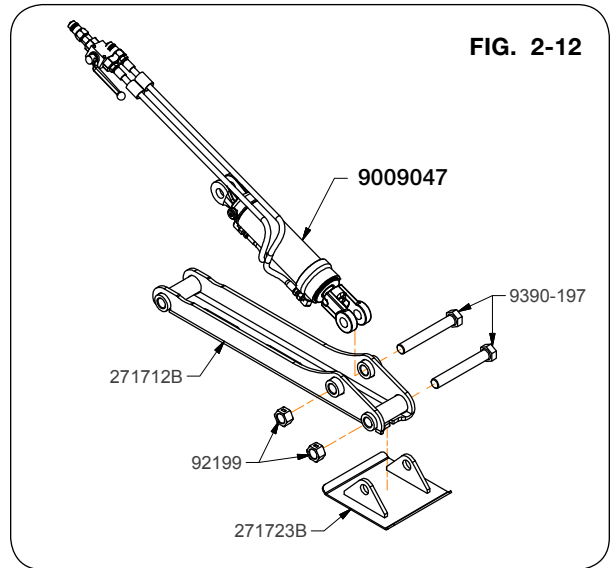

Upper Side Ladder Extension

⚠ WARNING

- FALLING OR LOWERING EQUIPMENT CAN CAUSE SERIOUS INJURY OR DEATH. KEEP EVERYONE AWAY FROM EQUIPMENT WHEN SUSPENDED, RAISING, OR LOWERING.
- KEEP HANDS CLEAR OF PINCH POINT AREAS.
- DO NOT ALLOW ANYONE TO RIDE ON THE LADDER. MAKE SURE EVERYONE IS CLEAR BEFORE OPERATING MACHINE OR TOWING VEHICLE.
- TO PREVENT PERSONAL INJURY OR DEATH, ALWAYS ENSURE THAT THERE ARE PEOPLE WHO REMAIN OUTSIDE THE CART TO ASSIST THE PERSON WORKING INSIDE, AND THAT ALL SAFE WORKPLACE PRACTICES ARE FOLLOWED. THERE IS RESTRICTED MOBILITY AND LIMITED EXIT PATHS WHEN WORKING INSIDE THE IMPLEMENT.
- NEVER ENTER A CART CONTAINING GRAIN. FLOWING GRAIN TRAPS AND SUFFOCATES VICTIMS IN SECONDS.

NOTE: Ensure ladder and steps are free from snow/debris before changing ladder positions and climbing.

NOTE: To change ladder assembly positions, refer to “Ladder Operation” in the OPERATION section.

1. Park the unit on a firm, level surface. Block the machine to keep it from moving. Set the vehicle parking brake, shut off the engine and remove the ignition key.
2. Move the upper ladder extension (289707B) from shipping position by removing the 5/16”-18UNC x 3/4” carriage bolts (9388-024), 5/16” flat washers (9405-064) and 5/16”-18UNC lock nuts (9008441). Keep hardware for next step. (Fig. 2-15)
3. Using hardware from step 2, attach upper ladder extension to the higher set of holes to be in operating position. (Fig. 2-15, Fig. 2-16 and 2-17)
4. Torque hardware to 17 ft.-lbs.

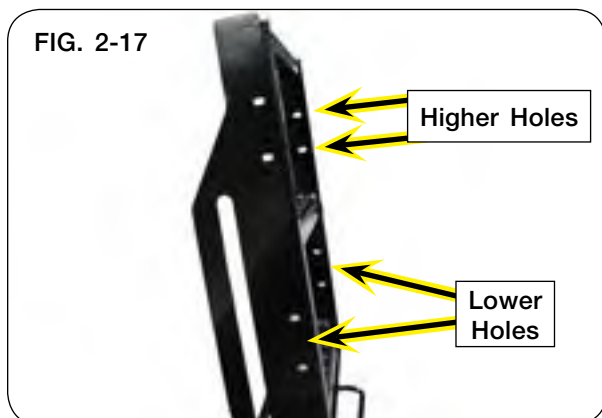
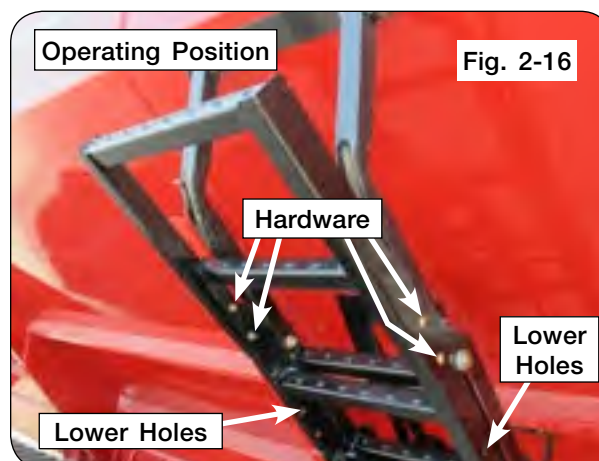
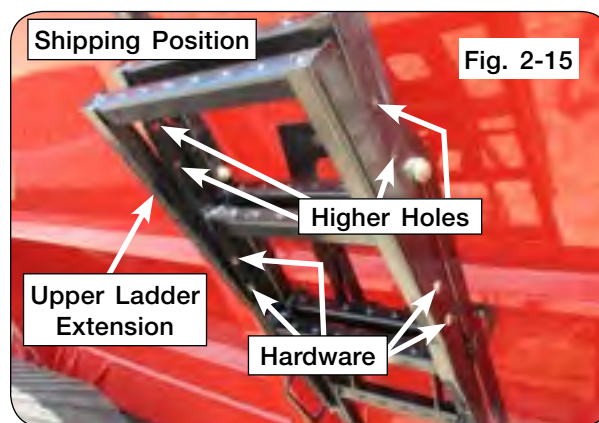

Wheel & Tire Set Up

Tire Pressure

Tire pressure must be verified before first use and adjusted as necessary. Refer to MAINTENANCE section of this manual for information on tire pressure.

Wheel Nuts

WARNING

- **FALLING OBJECTS CAN CAUSE SERIOUS INJURY OR DEATH. DO NOT WORK UNDER THE MACHINE AT ANY TIME WHILE BEING HOISTED. BE SURE ALL LIFTING DEVICES AND SUPPORTS ARE RATED FOR THE LOADS BEING HOISTED. THESE ASSEMBLY INSTRUCTIONS WILL REQUIRE SAFE LIFTING DEVICES UP TO 30,000 LBS. SPECIFIC LOAD RATINGS FOR INDIVIDUAL LOADS WILL BE GIVEN AT THE APPROPRIATE TIME IN THE INSTRUCTIONS.**
- **EYE PROTECTION AND OTHER APPROPRIATE PERSONAL PROTECTIVE EQUIPMENT MUST BE WORN WHILE SERVICING IMPLEMENT.**
- **KEEP HANDS CLEAR OF PINCH POINT AREAS.**
- **TIPPING OR MOVEMENT OF THE MACHINE CAN CAUSE SERIOUS INJURY OR DEATH. BE SURE MACHINE IS SECURELY BLOCKED.**

CAUTION

- **IMPROPERLY TORQUED WHEEL NUTS/BOLTS CAN CAUSE A LOSS OF IMPLEMENT CONTROL AND MACHINE DAMAGE. WHEEL NUTS/BOLTS MUST BE CHECKED REGULARLY. SEE TORQUE PAGE IN THE MAINTENANCE SECTION FOR PROPER WHEEL NUT/BOLT SPECIFICATIONS. WARRANTY DOES NOT COVER FAILURES CAUSED BY IMPROPERLY TORQUED WHEEL NUTS/BOLTS.**

IMPORTANT

- *Install wheels with the tires in the narrowest position. Installing wheels without the proper inset/outset could result in hub or spindle failure. This will cause substantial damage to cart and is not covered by warranty. Inset/outset will vary depending on tire size. Consult dealer for proper inset/offset.*

Wheel nuts must be torqued to specification. Refer to MAINTENANCE section for proper wheel nut torque.

The wheel dish will put the tires to the narrowest or widest position.

SMV Emblem & SIS Decals

The reflective surface of the SMV must face rearward. This may require removal of film protecting the reflective surface or removing and reinstallation of the SMV. (Fig. 2-18)

Install the SMV with the wide part at the bottom and reflective surface facing outward. (FIG. 2-18)



Ensure the front and rear SIS decals are clean and visible after shipping. (FIG. 2-19)

For 20 M.P.H. SIS decals, order 9008715 for the front & 9008714 for the rear.

For 30 K.P.H. SIS decals, order 9008721 for the front & 9008720 for the rear.

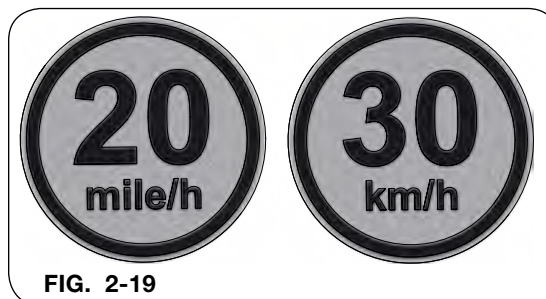

Video System (Optional)

The video system includes its own installation instruction sheet. Reference the provided instruction sheet.

Belt Engagement

WARNING

- **MOVING OR ROTATING COMPONENTS CAN CAUSE SERIOUS INJURY OR DEATH. ENSURE SERVICE COVERS, CHAIN/BELT COVERS AND CLEAN-OUT DOORS ARE IN PLACE AND SECURELY FASTENED BEFORE OPERATING UNIT.**

The unit is shipped without tension applied to the belts. To engage the tensioner use the belt tensioner handle, located on the front left-hand side of the grain cart, behind the first panel. Verify the belts are correctly aligned and are seated in both sheaves. If belt hangs over edge of sheave, detention idler, adjust and retention idler. (Figs. 2-20 and 2-21)

Rotate the handle downwards to engage tensioner. (Fig. 2-20)

NOTE: See MAINTENANCE section - V-Belt Alignment - for more details.



Operational Check

WARNING

- **MOVING OR ROTATING COMPONENTS CAN CAUSE SERIOUS INJURY OR DEATH. ENSURE SERVICE COVERS, CHAIN/BELT COVERS AND CLEAN-OUT DOOR ARE IN PLACE AND SECURELY FASTENED BEFORE OPERATING UNIT.**

IMPORTANT

- *Before running the auger pivot, the vertical auger cleanout door must be closed to prevent machine damage.*

NOTE: The grain cart must have 12V power (blue wire) on the 7-pin plug. Without 12VDC, the auger fold and spout rotate will not operate.

Perform the clean-out door steps to prepare the cart for operation:

1. Retrieve lynch pin from toolbox for the horizontal clean-out doors.
2. Close clean-out doors. Refer to “Vertical & Horizontal Clean-Out Door Operation” in the OPERATION section.

Once set-up has been completed, run the cart to check for operation and functionality:

1. Lights - Work, Turn, Brake
2. Flow Door
3. Flow Door Indicator
4. Auger Fold
5. Auger Pivot
6. Spout Rotate (if applicable)
7. Spout Tilt
8. Auger Startup & Shut-down
9. Brakes (if applicable)
10. Tarp
11. Video System Camera
12. Scale (if applicable)



Section III Operation

Preparing Tractor	3-3
Preparing Cart.....	3-4
Hardware.....	3-4
Pivot Pins	3-4
Hitch	3-4
Rear Drop Hitch (Optional) - For SN B44630100 & Higher.....	3-4
Auger	3-5
Hydraulic System.....	3-5
Optional Hydraulic Brake System.....	3-5
Tires/Wheels.....	3-5
Hitching to Tractor	
Drawbar Connection	3-6
Jack Usage.....	3-7
Optional Hydraulic Jack Usage	3-8
Transport Chain Connection.....	3-9
Hydraulic Connections.....	3-10
Optional Implement Brake Connection	3-11
Electrical Connections.....	3-12
Towing	3-13
Auger Operation	
PTO-Driven Auger	3-14
Vertical Auger Fold.....	3-16
Auger Field Rest Position.....	3-17
Auger Road Transport Position.....	3-18
Upper Auger Rest Adjustments	3-19
Auger Overload Procedure.....	3-20
Electric Over Hydraulic Operation (Optional)	
Electric/Hydraulic Connection.....	3-21
Auger Fold & Spout Operation.....	3-22
Flow Door Operation	3-23
Auger Fold to Transport.....	3-23
Cart Loading Sequence	3-24
Vertical & Horizontal Cleanout Door Operation	
Closing Vertical Cleanout Door.....	3-25
Opening Vertical Cleanout Door	3-26
Horizontal Cleanout Door.....	3-27
In-Line Tandem.....	3-28
Optional Implement Brake System for In-Line Tandem.....	3-28
Ladder Operation	
Side Ladder Operation - For SN B40560100 & Higher.....	3-29
Rear Ladder Operation - For SN B44630100 & Higher.....	3-33
Rear Access Door Operation - For SN B44630100 & Higher.....	3-35
Rear Drop Hitch Operation (Optional) - For SN B44630100 & Higher	
Storage to Working Position.....	3-37
Rear Hitch Connection.....	3-38
Electrical Connection	3-39
Rear Drop Hitch Adjustment	3-40
Video System (Optional).....	3-41
Weather Guard Tarp.....	3-41
Wireless Receiver and Control Box Location - For SN B43110100 & Higher.....	3-43

FOR SCALE, TRACK, UHARVEST, ELECTRIC TARP, AND / OR WATER DELIVERY SYSTEM INFORMATION, PLEASE REFER TO THE INDIVIDUAL MANUALS.

Operating Checklist

- Read and understand all safety precautions before operating cart.
- R.V. antifreeze needs to be completely flushed from the Water Delivery System and disposed of properly. Make certain the Water Delivery System only contains water before placing the Water Delivery System in service. (If applicable)
- Set or Calibrate tractor PTO control engagement to MINIMUM setting. Refer to tractor operator's manual for setting information.
- Torque wheel nuts as specified in MAINTENANCE section.
- Verify track has been aligned and is properly conditioned. Refer to 50" / 42" Equalizer Track manual (267909) or 36" x 148" Hydraulic Tension Track manual (267997) MAINTENANCE section for alignment information. (If applicable)
- Verify track grease pump reservoir is full, if equipped. Refer to track auto grease pump instruction sheet (282986) for setting information.
- Check tire pressure and inflate tires as needed to specified air pressure. See "Tire Pressure" in MAINTENANCE section. (if applicable)
- Lubricate all grease fittings and check gearbox oil level.
- Inspect cleanout door assembly for proper adjustment, refer to "Vertical & Horizontal Clean-Out Door Operation" in the OPERATION section.
- Test operation and functionality of work lights, flow door, flow door indicator, auger fold, auger pivot, spout rotate, spout tilt, tarp, rear access door, and if equipped, rear drop hitch, hydraulic jack stand, scale, joystick, scale remote display, video system, and water delivery system.
- Verify all reflective decals are correctly located.
- Check SMV sign and SIS decals are clearly visible with the cart attached to the tractor.
- Verify transport lights are working properly. Check and follow all regulations before towing on a road or highway.
- Verify tractor drawbar height and length. See "Preparing Tractor" in this section.
- Verify PTO length, see "Verify Telescoping PTO Shaft Length" in MAINTENANCE section.
- Align and properly tension belts. See "Belt Tightener Adjustment" and "V-Belt Alignment" in MAINTENANCE section.
- Ensure screens over horizontal auger are in place and properly secured.
- Ensure all cleanout doors and rear access door are closed and latched.
- Ensure side and rear ladders are in storage position.
- Ensure transport chains are installed and properly secured. See "Transport Chain Connection" in OPERATION section.
- Test run the augers. See "Auger Operation" in OPERATION section.

Preparing Tractor

Before operating cart, read the tractor Operator's Manual and gain an understanding of its safe methods of operation.

Check the tractor brakes and transport lights. Make sure they are in proper working order.

On carts equipped with optional hydraulic brake system, make sure the tractor is equipped with components necessary for operating the cart's hydraulic brakes. This cart is compatible with ISO:5676 brake systems. Consult your tractors Operator's Manual or your tractor dealer for appropriate brake control system.

If equipped, check the tractor and cart electric tarp connection. Refer to electric roll tarp manual (26487) for details.

Set tractor PTO modulation to MINIMUM. Check that your tractor has the latest PTO engagement software from the OEM. If unsure, contact your local dealer for tractor capabilities and recommended setting for grain cart operation.

Read the tractor Operator's Manual for more information on tractor drawbar distance.

Check the tractor hydraulic oil reservoir and add oil if needed.

Verify that the tractor is adequately ballasted for drawbar operation at the anticipated draft load. See tractor manual for ballasting instructions.

If possible, adjust the tractor drawbar vertically so the topside of the drawbar is approximately 17-22 inches from the ground. Ensure that the drawbar is locked in the center position.

NOTE: The grain cart comes with a CAT 4 hitch utilizing a 2" diameter pin. A CAT 5 hitch is available for a 2 3/4" diameter pin.

CAUTION

- **USE OF NON-MATCHING CATEGORY HITCH AND TRACTOR DRAWBAR CONNECTION WILL RESULT IN POOR HITCH PERFORMANCE AS WELL AS DAMAGE TO TRACTOR, IMPLEMENT OR BOTH.**

Hitch pin sizes for each Category to help identify which Category drawbar you have.

Category 4 2" Diameter (50 mm)

Category 5 2-3/4" Diameter (70 mm)

On tractors equipped with a 3-point hitch, raise and secure the linkage to prevent interference with the cart tongue, hydraulic hoses and the hydraulic drive option during turning. It may be necessary to remove tractor 3-point quick attach to avoid damage during turning.

Preparing Cart

Perform the service checks below. Repair or replace any damaged or worn parts before operating.

Hardware

Check for loose bolts and nuts, and tighten as needed. Check again after the first half-day of operation.

Pivot Pins

Check that all pins are in place and in good condition. Replace any worn, damaged or missing pins.

Hitch

Check hitch wear plates for damage and wear. Ensure correct size of hitch pin adapter bushing that is being used. Select correct size for the hitch pin/drawbar you are using.

Rear Drop Hitch (Optional) - For SN B44630100 & Higher

Check rear drop hitch wear plates for damage and wear. Check that the hitch pin is in place and in good condition. Replace worn, damaged or missing hitch pin.

Preparing Cart (continued)

Auger

Inspect auger for damage and wear.

Hydraulic System

Check all hoses and cylinders for signs of leakage. Hoses should not be kinked, twisted or rubbing against sharp edges. Re-route or repair hoses as necessary. Refer to SAFETY section for additional information on safe repair and inspection of hydraulic components.

Optional Hydraulic Brake System

On carts equipped with optional hydraulic brake system, ensure hose is properly connected to the tractor's hydraulic trailer brake coupler. Consult your tractor's Operator's Manual or your tractor dealer for more information.

Ensure brakes are bled before use. See "Bleeding Procedure For Braking System" in the MAINTENANCE section for additional information.

The optional hydraulic brake system is designed to comply with ISO:5676 compatible hydraulic brake coupler.

IMPORTANT

- *Failure to use correct coupler or incorrect plumbing may result in brake lockup. Damage due to brake lockup is not covered under warranty.*

Tires/Wheels

Check tire pressures and maintain at recommended values listed in the MAINTENANCE section of this manual.

CAUTION

- **IMPROPERLY TORQUED WHEEL NUTS/BOLTS CAN CAUSE A LOSS OF IMPLEMENT CONTROL AND MACHINE DAMAGE. WHEEL NUTS/BOLTS MUST BE CHECKED REGULARLY. SEE TORQUE PAGE IN THE MAINTENANCE SECTION FOR PROPER WHEEL NUT/BOLT SPECIFICATIONS. WARRANTY DOES NOT COVER FAILURES CAUSED BY IMPROPERLY TORQUED WHEEL NUTS/BOLTS.**

IMPORTANT

- *Install wheels with the tires in the narrowest position. Installing wheels without the proper inset/offset could result in hub or spindle failure. This will cause substantial damage to cart and is not covered by warranty. Inset/offset will vary depending on tire size. See SET UP section for proper inset/offset.*

For questions regarding new tire warranty, please contact your local original equipment tire dealer. **USED TIRES CARRY NO WARRANTY.** Tire manufacturers' phone numbers and web sites are listed in the MAINTENANCE section of this manual for your convenience.

Hitching to Tractor

Drawbar Connection

This cart is intended to be hitched to a tractor drawbar. Do not attempt to hitch to any other location on the tractor other than the drawbar.

The cart comes with a CAT 4 hitch for use with a 2" diameter hitch pin and designed for a clevis-type tractor drawbar. If a 1 1/2" or 1 3/4" diameter hitch pin is used, a corresponding bushing must be inserted into the hitch tang and held in place with o-rings. (Figure 3-1)

NOTE: CAT 5 tongue is available for a 2 3/4" diameter pin. Contact your dealer for a CAT 5 tongue/hitch, if required.

NOTE: Use of the proper hitch pin/bushing will prevent excessive wear and tear on both the cart and tractor.

NOTE: Bushings and o-rings to adapt the CAT 4 hitch are stored in the toolbox on the right-hand side of the cart.

- Lock tractor drawbar in center position.
- Refer to the tractor Operator's Manual for information on tractor drawbar length.

WARNING

- **DO NOT STAND BETWEEN THE CART AND TRACTOR WHEN HITCHING. ALWAYS ENGAGE PARKING BRAKE AND STOP ENGINE BEFORE INSERTING HITCH PIN.**
- Place wear shoe (281898-CAT 4; 281899-CAT 5) between tractor hitch and grain cart hitch. (Figure 3-2)
- After inserting drawbar pin, secure drawbar pin with a locking device to prevent uncoupling during use.

NOTE: Hitch tang can be flipped providing a drawbar connection height difference of 2 7/8" (Figure 3-3). Position the hitch tang to help assure a level cart when loaded, or the rear of the hopper slightly higher than the front, to maintain rear slope cleanout. Whenever the hitch tang is flipped, the driveline clearances need to be reviewed.

FIG. 3-1

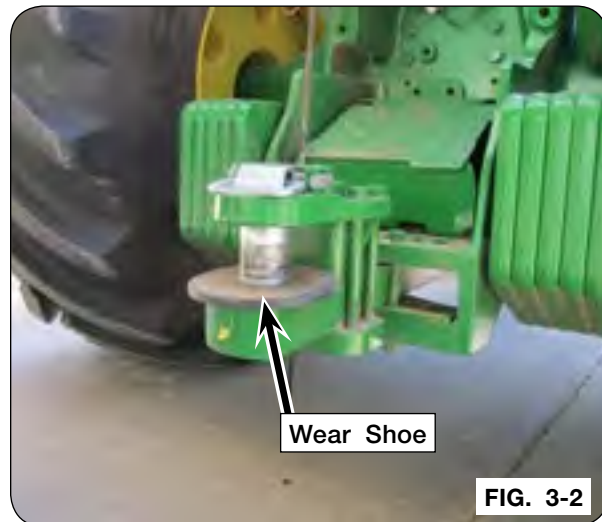
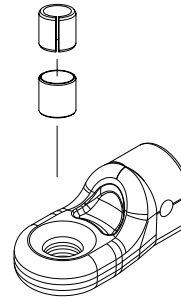

FIG. 3-2

2 7/8" Higher Than
The Standard Position

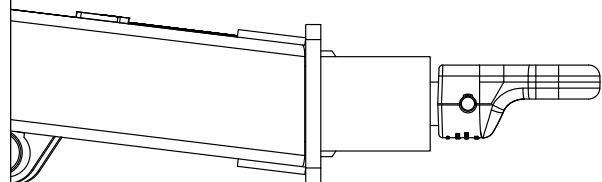

FIG. 3-3

Hitching to Tractor (continued)

WARNING

- UNHITCHING A LOADED CART CAN CAUSE SERIOUS INJURY OR DEATH DUE TO TONGUE RISING OR FALLING. ALWAYS HAVE A LOADED CART ATTACHED TO A TRACTOR. THE JACK IS INTENDED TO SUPPORT AN EMPTY CART ONLY.

Jack Usage

Use jack to support an empty grain cart, never a loaded grain cart. Always have a loaded grain cart hooked to tractor. Attach jack to left inside frame using pin and hair pin. Pivot the jack 90 degrees and reinstall pin for field use. (Fig. 3-4)

IMPORTANT

- After cart is hitched to tractor, pivot jack to storage location. (Fig. 3-4 and 3-5)

FIG. 3-4

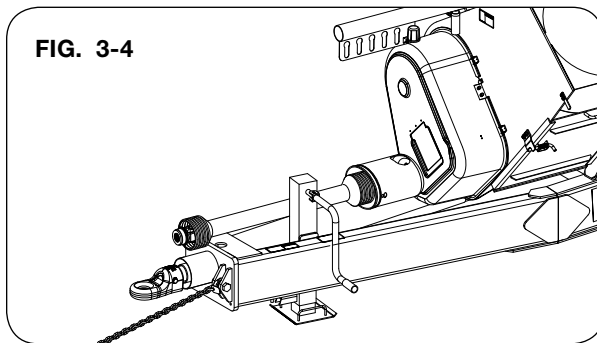

FIG. 3-5



Hitching to Tractor (continued)

Optional Hydraulic Jack Usage

WARNING

- HIGH-PRESSURE FLUIDS CAN PENETRATE THE SKIN AND CAUSE SERIOUS INJURY OR DEATH. LEAKS OF HIGH-PRESSURE FLUIDS MAY NOT BE VISIBLE. USE CARDBOARD OR WOOD TO DETECT LEAKS IN THE HYDRAULIC SYSTEM. SEEK MEDICAL TREATMENT IMMEDIATELY IF INJURED BY HIGH-PRESSURE FLUIDS.
- TIPPING OR MOVEMENT OF THE MACHINE CAN CAUSE SERIOUS INJURY OR DEATH. BE SURE THE MACHINE IS SECURELY BLOCKED.
- OPENING OF HYDRAULIC VALVE CAN CAUSE SUDDEN MACHINE MOVEMENT. KEEP CLEAR OF MACHINE WHEN OPENING VALVE.

IMPORTANT

- After cart is hitched to tractor, attach hydraulic hoses to tractor and retract hydraulic cylinder to store hydraulic jack between the frame rails. (FIG. 3-7)

Use hydraulic jack to support an empty grain cart, never a loaded grain cart. Always have a loaded grain cart hooked to tractor.

Always close the manual valve for the hydraulic jack for in-field use and when unhitched from the tractor.

1. Remove hoses from storage slots.
2. Attach jack cylinder hose couplers to tractor.
3. Open valve to allow hydraulic flow.
4. Use tractor hydraulic valve to extend cylinder and lift tongue.
5. Once attached to tractor drawbar, retract cylinder to lower tongue and to raise jack into storage position.
6. Close valve, relieve pressure on couplers (see tractor operators manual for procedure) and then disconnect hose couplers from tractor.
7. Place hose couplers into storage caddy. Be sure to route hoses to clear PTO driveline during operation.
8. Check for leaks.

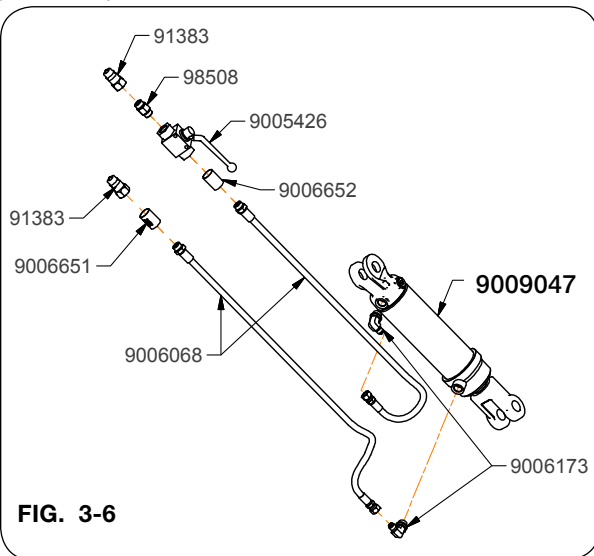

FIG. 3-6



FIG. 3-7

Hitching to Tractor (continued)

Transport Chain Connection

CAUTION

- ALWAYS USE TRANSPORT CHAIN WHEN TRANSPORTING IMPLEMENTS. FAILURE TO USE A TRANSPORT CHAIN COULD CAUSE PERSONAL INJURY IF CART BECOMES DISENGAGED.
- REPLACE TRANSPORT CHAIN IF ANY LINK OR END FITTING IS BROKEN, STRETCHED, DAMAGED OR NOT FUNCTIONING. DO NOT WELD TRANSPORT CHAIN.
- USE ONLY AN UNVERFERTH ASABE TRANSPORT CHAIN WITH A WEIGHT RATING EXCEEDING THE GROSS COMBINED WEIGHT OF ALL TOWED IMPLEMENTS. CONTACT YOUR UNVERFERTH DEALER FOR ADDITIONAL INFORMATION.

Tractor must be equipped with a transport chain support. Always use intermediate support when connecting cart directly to a tractor. DO NOT use intermediate chain support as the chain attaching point. See tractor operator's manual for proper chain attachment. FIG. 3-8 shows how the transport chain must be installed between implement and towing vehicle.

The standard transport chain is rated for towing the grain cart empty on public roads. Never tow a loaded grain cart on public roads.

If the grain cart has the rear hitch installed, the standard transport chain must be replaced with PF1238-19 61,000 LBS. transport chain. The PF1238-19 61,000 LBS. transport chain is rated for the empty grain cart plus the rear hitch capacity of 20,000 LBS.



FIG. 3-8

Hitching to Tractor (continued)

Hydraulic Connections

Clean hydraulic hose couplers before connecting to the tractor. For convenience, this unit is equipped with sleeve hose markers attached to the hydraulic hoses. This will help in identifying the hose function and correct hook up. (FIG. 3-9)

NOTE: Hydraulic sleeve color may not match the tractor SCV color.

Color	Function
Red	Flow Door Open / Close
Yellow	Spout Tilt In / Out
Green	Auger Fold / Unfold
Black	Jack Raise / Lower
Orange	Auger Pivot Up / Down
Optional (Red)	Hydraulic Pressure and Return Joystick / Spout Rotate
Optional (Blue)	Brakes

After initial set-up or replacement of any hydraulic component on the cart, air must be removed from the cart's hydraulic system. Reference "Hydraulic System - Purge Hydraulic System" section in the MAINTENANCE section.

Route hoses away from areas that may cause abrasion or kinking of hoses during operation.

(Continued on next page)

Hitching to Tractor (continued)

Hydraulic Connections (continued)

Before disconnecting hoses from tractor, place tractor in Park and shut PTO off, operate auger fold and pivot to the lowest positions. Where possible, remove hydraulic pressure loads and avoid potential pressure buildup in the lines from long storage periods such as upper auger not in rest position. If equipped with hydraulic jack, extend jack to desired position, turn valve to closed position. See tractor operator's manual for proper procedure to relieve pressure from the lines. After SCV pressures have been relieved and tractor engine is off, disconnect hoses from tractor. Install couplers into storage slots provided. (FIG. 3-9)

FIG. 3-9



Optional Implement Brake Connection

Connector must comply with ISO:5676 standards. Brake hydraulic hose is designated with blue color band. See tractor's operators manual for connection location.

Hitching to Tractor (continued)

Electrical Connections

This cart is equipped with a seven-pin SAE connector plug that will connect with the receptacle found on most newer tractors. If your tractor does not have this type of receptacle, an SAE J-560 seven-point socket can be purchased from your Parker dealer (Part number 92824). (FIG. 3-10)

NOTE: 7-pin connector must be plugged into the tractor in order for the spout system to operate.

The wiring schematic for this cart, shown in the MAINTENANCE section, complies with AS-ABE Standards. Always verify correct electrical function before using this cart.

If equipped, check the tractor and cart electrical tarp connection. Refer to electric roll tarp manual (26487) for details.

This unit is equipped with Side Marker lights for enhanced visibility. These lights will have different functionality depending upon the tractor lighting selection.

- When the tractor field lights switch is on; the Side Marker lights and the amber turn signal lights are on solid and will not flash.
- When the flashers and/or turn signal is on; the Side Marker lights flash in unison with their respective side's amber turn lamp.

Compliance with all lighting and marking laws is the responsibility of the operator at the time of travel.

See federal regulation 49 CFR 562; available at www.govinfo.gov for US federal law requirements.

See your Parker dealer for additional brackets, reflectors, or lights to meet your requirements.

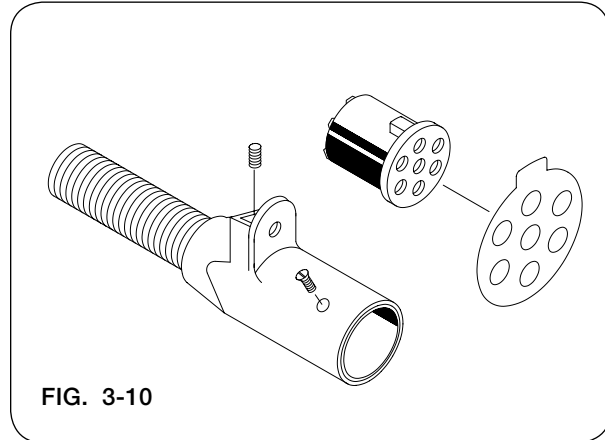

FIG. 3-10

Hitching to Tractor (continued)

Towing

Even if the cart is equipped with brakes, ensure that the towing vehicle has adequate weight and braking capacity to tow this grain cart and up to 20,000 lbs. on the optional towed header transport. See the towing vehicle manual for towing capacity. Never tow a loaded grain cart over public roads.

IMPORTANT

- *To prevent damage to the cart brake system, manually release pressure from the cart hydraulic brakes if towing without a hydraulic brake equipped vehicle.*

Maximum speed of cart should never exceed 20 m.p.h. Do not exceed 10 m.p.h. during off-highway travel. Do not exceed 8 m.p.h. when cart is fully loaded.

Secure drawbar pin with a locking device and lock tractor drawbar in centered position.

The PTO drive shaft must be properly attached to the tractor during transport. See “Driveline Install” in SET UP section and “PTO Shaft and Clutch” in MAINTENANCE section before connecting the PTO drive shaft to the tractor.

Secure transport chain to tractor before towing.

Carts equipped with brakes require a tractor with rear hydraulic brake ports. If your tractor is not equipped with rear hydraulic brake ports, consult your dealer.

Verify brake operation/release before towing.

CAUTION

- **THE STANDARD TRANSPORT CHAIN IS DESIGNED ONLY FOR AN EMPTY GRAIN CART DURING ROAD TRAVEL.**

IMPORTANT

- *Upper auger must be in Transport Position for public road travel.*
- *Position vertical auger with discharge hood within hopper width for public road travel.*

Regulate speed to road conditions and maintain complete control.

It is probable that this cart is taller, wider and longer than the towing tractor. Become aware of and avoid all obstacles and hazards in the travel path of the equipment, such as power lines, ditches, etc.

Slow down before making sharp turns to avoid tipping. Drive slowly over rough ground and side slopes.

Always have auger folded into transport position when auger is not in use. (Fig. 3-11)



Road Transport Position Shown

FIG. 3-11

Auger Operation

PTO Driven Auger

DANGER

- ELECTROCUTION WILL CAUSE SERIOUS INJURY OR DEATH. ELECTROCUTION CAN OCCUR WITHOUT DIRECT CONTACT. KEEP AWAY FROM ALL ELECTRICAL LINES AND DEVICES.



WARNING

- NEVER ENTER CART WITH AUGER OR TRACTOR RUNNING. SERIOUS OR FATAL INJURY CAN OCCUR DUE TO ENTANGLEMENT WITH ROTATING COMPONENTS. ALWAYS STOP ENGINE AND REMOVE KEY BEFORE ENTERING CART.
- TO PREVENT PERSONAL INJURY OR DEATH, ALWAYS ENSURE THAT THERE ARE PEOPLE WHO REMAIN OUTSIDE THE CART TO ASSIST THE PERSON WORKING INSIDE, AND THAT ALL SAFE WORKPLACE PRACTICES ARE FOLLOWED. THERE IS RESTRICTED MOBILITY AND LIMITED EXIT PATHS WHEN WORKING INSIDE THE IMPLEMENT.

1. Before loading cart or operating auger, verify that the flow control door is closed.

NOTE: If spout rotate moves out of center, the auger will not unfold to unloading position. The spout must be manually rotated to center position. See “Manual Override for Optional Electric Over Hydraulic System” in the MAINTENANCE section.

2. Choose an area free from obstructions and unfold auger into unloading position. Allow sufficient time for the cylinder to fully engage the two augers and over-center latch to fully engage.
3. Engage PTO at low engine RPM, then increase engine RPM until 1000 PTO RPM is reached.

IMPORTANT

- *Operating the PTO at less than 1000 RPM can result in damage to the PTO and driveline components in addition to excessive auger wear and cart vibration.*

Auger Operation (continued)

4. Open flow control door to desired unloading rate. Numbers on the auger tube provide a point of reference for operator convenience. (FIG. 3-12)
5. To slow or stop grain flow, close flow door, do not reduce tractor RPM. Close flow door fully when unloading is complete.

NOTE: If an overload occurs, see “Auger Overload Procedure.”

NOTE: It is not recommended to disengage auger with flow control door open. Auger system will require substantially more torque to start, placing extra stress on both cart and tractor driveline.

Cart is equipped with baffles that can be adjusted to accommodate the flow of different materials and/or torque demands associated with different materials. See the MAINTENANCE section for the procedure.

6. When auger is empty, reduce PTO rpm to idle, and stop PTO.
7. After PTO has come to a complete stop, align the checkered flag decals to locate center as shown in FIG. 3-13.
8. Once spout is centered, fold auger to the transport position or field position.

NOTE: Spout can be TILTED to any position, but must be ROTATED to center for auger to fold.

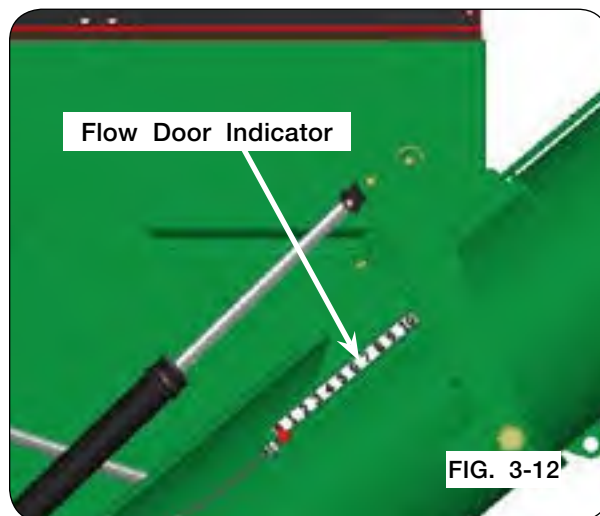

FIG. 3-12



FIG. 3-13

Spout Centered Position

Auger Operation (continued)

Vertical Auger Fold

WARNING

- DO NOT STAND ON LADDER OR FRAME UNLESS TRACTOR ENGINE IS TURNED OFF AND KEYS ARE REMOVED FROM THE IGNITION.

Actuate hydraulic auger fold circuit to move vertical auger between transport and operating positions. When unfolding auger, allow sufficient time for cylinder to rotate the outside fold link into an over-center position. (FIG. 3-14)

NOTE: Auger spout will not rotate until auger is fully extended and auger will not fold until the spout is centered. It may be necessary to manually rotate auger spout in order to unfold the auger. See “Manual Override for Optional Electric Over Hydraulic System” in the MAINTENANCE section for details.

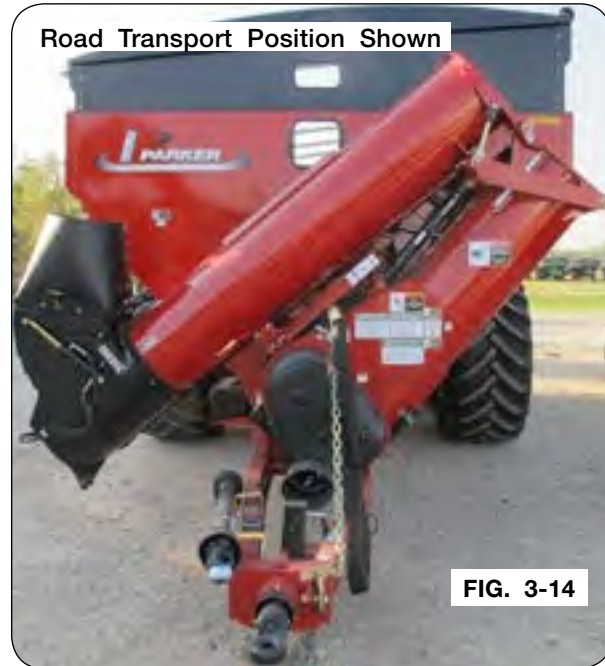

Auger Operation (continued)

Auger Field Rest Position

IMPORTANT

- Auger field rest is *ONLY* for use in the field. Auger must be folded to road transport position during road transport.
1. Extend auger to the unload position. Shut-off tractor's engine and remove the ignition key.



2. Remove hairpin cotter from latch pin (Figure 3-15) and pull latch pin to disengage (Figure 3-16). Raise auger rest stand up to field position and release latch pin. Make sure the pin is engaged in the field position hole and re-install hairpin removed earlier in this step.

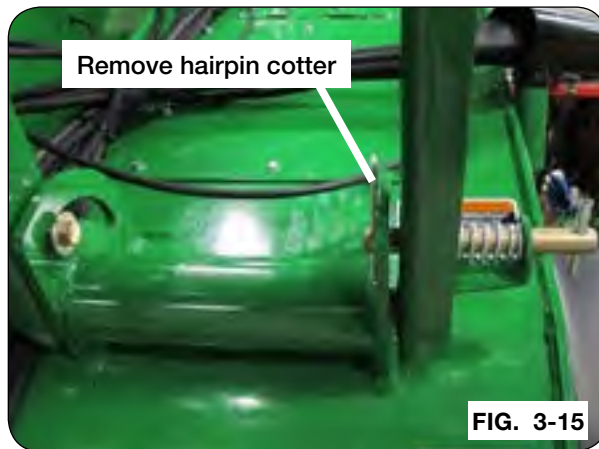

FIG. 3-15

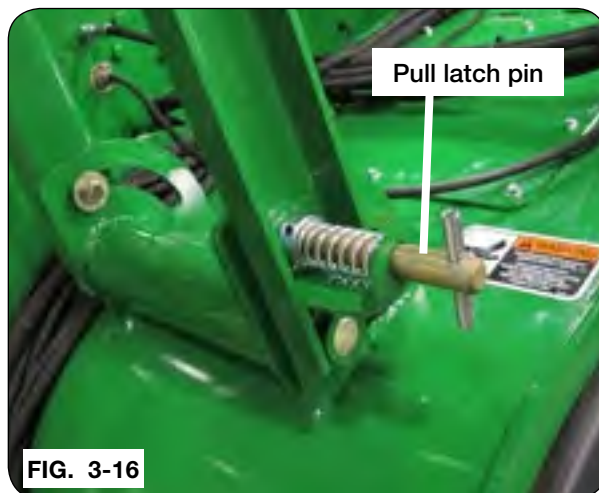

FIG. 3-16

3. Fold auger back to field rest position (Figure 3-17), making sure upper auger rest engages the field rest tube and activates the auger switch.

NOTE: Upper auger rest is factory adjusted. Bolts can be used for re-alignment of upper auger rest. See FIG. 3-17.



FIG. 3-17

Auger Operation (continued)

Auger Road Transport Position

1. Extend auger to the unload position. Shut-off tractor's engine and remove the ignition key.



2. Remove hairpin and pull latch pin towards you to disengage. Lower field rest to the road transport position and release the latch pin (Figure 3-18). Make sure the pin is engaged in the road transport position hole and re-install hairpin removed earlier in this step.
3. Fold auger down to road transport position. (Figure 3-19)



Auger Operation (continued)

Upper Auger Rest Adjustments

1. Loosen mounting capscrews of upper auger rest . (Figure 3-20)
2. Raise auger approximately 6” out of the lower rest and install cylinder stops on the fold cylinder to prevent the auger from lowering unexpectedly.
3. Position upper auger rest as needed so that it appears to be centered over the lower auger rest tube.
4. Hand tighten the mounting capscrews of the upper auger rest.
5. Remove the cylinder stops installed in step 2, and lower the auger down into the lower rest.
6. Ensure the upper auger rest contacts the lower tube evenly.
7. Torque mounting capscrews to 65 ft.-lbs.

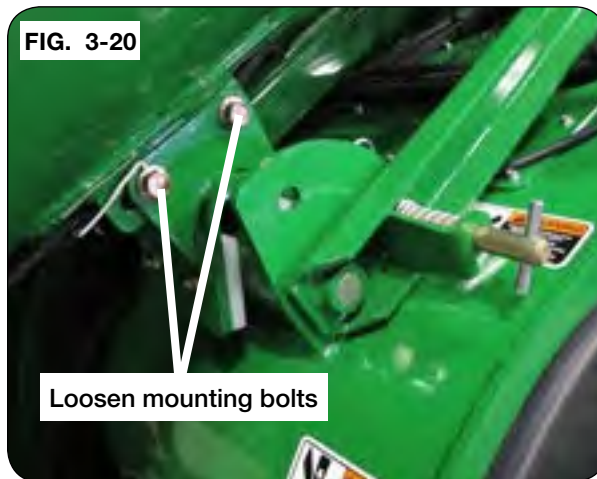

Auger Operation (continued)

Auger Overload Procedure

IMPORTANT

- Extensive operation while the clutch is slipping may damage drive components.

NOTE: When over loading occurs, drivelines equipped with cut-out clutch will make a “clicking” noise when torque has been exceeded. Immediately shut off PTO and shut the flow door.

NOTE: Once PTO RPM has significantly decreased, cut-out clutch will automatically reset.

1. Close flow door.
2. Shut-off the engine and remove the ignition key.

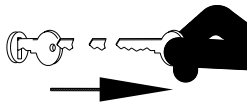

3. With the PTO off and driveline stopped, disengage the belt tensioner using the belt tensioner handle, this disengages the horizontal auger from the drivetrain. (FIG. 3-21)
4. Restart and engage the tractor PTO at low engine RPM.
5. Increase engine RPM until 1,000 PTO RPM is reached to empty the vertical auger.



IMPORTANT

- Operating the PTO at less than 1000 RPM can result in damage to the PTO and driveline components in addition to excessive auger wear and cart vibration.

6. Once vertical auger is empty, stop PTO.
7. Shut-off the engine and remove the ignition key.

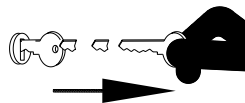

8. With the tractor PTO off and driveline stopped, reengage the belt tensioner using the belt tensioner handle. Return handle to storage. (FIG. 3-22)
9. Restart and engage the tractor PTO at low engine RPM.
10. Increase engine RPM until 1,000 PTO RPM is reached to empty the drag auger.

NOTE: If the grain cannot be relieved by above method, open bottom clean out doors (see “Vertical & Horizontal Clean-Out Door Operation” in this section) to remove grain from auger before repeating these steps to clean out auger.

Electric Over Hydraulic Operation (Optional)

Electric/Hydraulic Connection

Before operating cart, familiarize yourself with the functions associated with the joystick controller by operating with an empty cart.

The joystick comes with a mounting pin allowing storage inside the tractor cab when not in use.

1. Connect the red wire from power harness (9008251) to a key-switched +12VDC power supply. (Fig. 3-23)
2. Connect the white wire from power harness (9008251) to ground. (Fig. 3-23)

FIG. 3-23

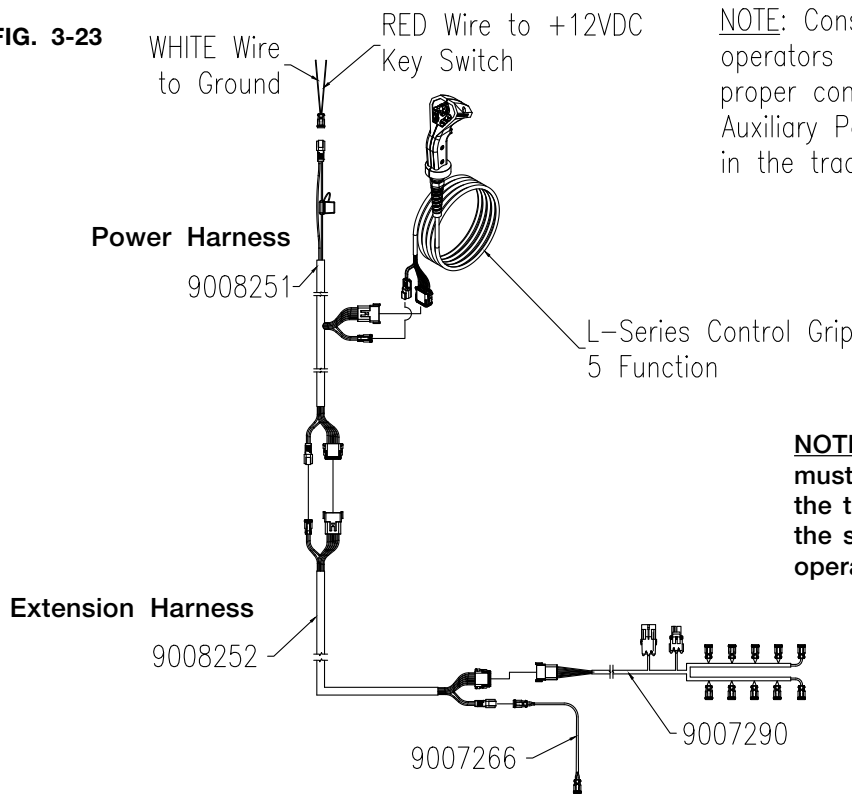

NOTE: Consult the tractor's operators manual for proper connection to the Auxiliary Power Outlet in the tractor cab.

NOTE: 7-pin connector must be plugged into the tractor in order for the spout system to operate.

Kit #291490B

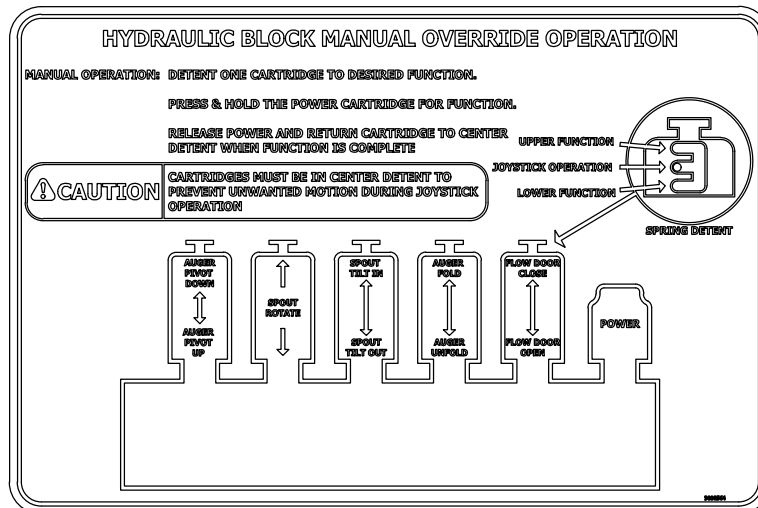

Electric Over Hydraulic Operation (Optional) (continued)

Auger Fold & Spout Operation

NOTE: Cartridge valves (9008416 and 9008463) must be locked in center position for joystick to function properly. Refer to “Manual Override for Opt. Electric Over Hydraulic System” in MAINTENANCE section.

1. Connect the Hydraulic Pressure and Return hoses to the tractor SCV remote so that the Pressure line is able to be put in continuous detent.
2. Place the remote in continuous detent so that the Hydraulic Pressure hose is pressurized and set the hydraulic flow to a maximum 6 gal/min to minimum 4 gal/min.
3. To fold auger out from transport to operating position, push down the auger unfold button on joystick face until the upper and lower auger are engaged and fold linkage is over center. See Fig. 3-24.

NOTE: Joystick has a double tap feature, which allows the operator to quickly double tap a function in order to operate it for a set time. If the auger fold or auger unfold buttons are double tapped, the function will stay on for 60 seconds to complete the full cycle without holding the buttons down. Pressing either of those buttons during these timed cycles will CANCEL the cycle. This double tap feature only applies to auger fold and unfold functions.

4. To pivot spout OUT away from cart, push hat switch toward OUT. Hold the switch until desired position is achieved. See Fig. 3-24.
5. To pivot spout IN toward cart, push hat switch toward IN. Hold the switch until desired position is achieved. See Fig. 3-24.
6. To pivot the entire auger UP, press and hold the auger pivot UP button until the desired height is achieved. See Fig. 3-24.
7. To pivot the entire auger DOWN, press and hold the auger pivot DOWN button until the desired height is achieved. See Fig. 3-24.
8. To pivot the spout FORWARD, push hat switch RIGHT. Hold the switch until desired position is achieved. See Fig. 3-24.
9. To pivot the spout REARWARD, push hat switch LEFT. Hold the switch until desired position is achieved. See Fig. 3-24.

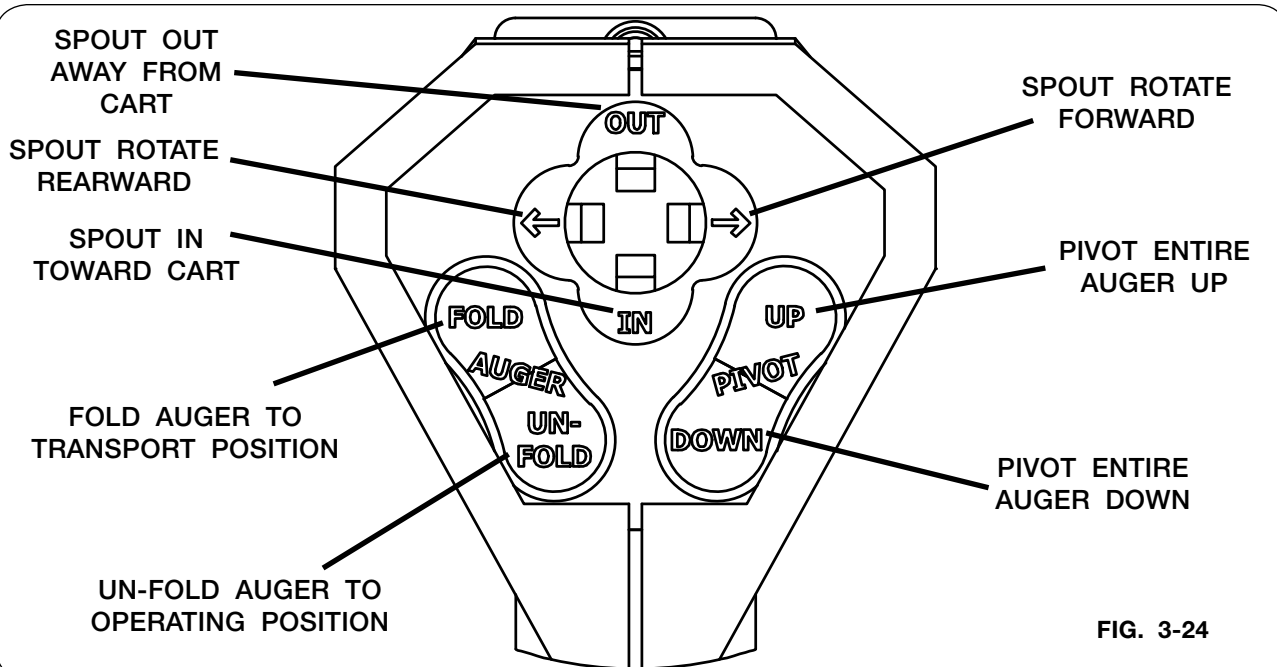

FIG. 3-24

Electric Over Hydraulic Operation (Optional) (continued)

Flow Door Operation

1. To open flow door, rotate the switch upwards. Observe flow door indicator to determine when to release trigger and stop flow door movement. See Fig. 3-25.

FIG. 3-25

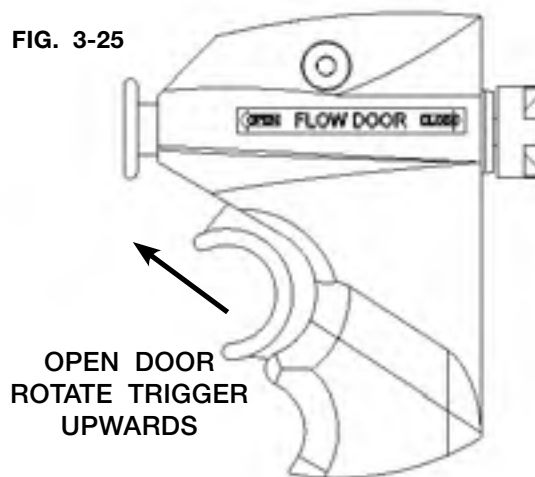

2. To close flow door, rotate the switch downwards. Observe the flow door indicator and release trigger when door is closed to desired position. See Fig. 3-26.

FIG. 3-26

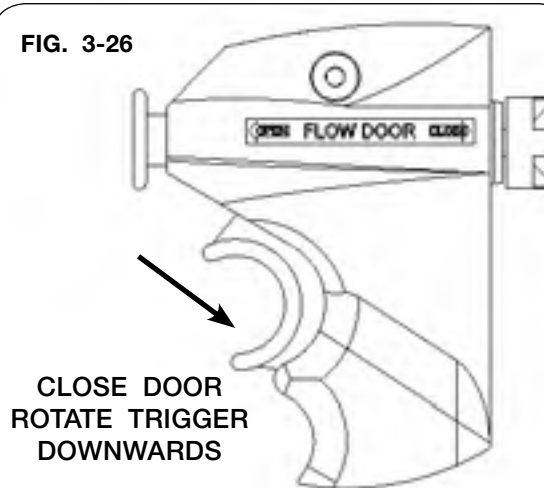

Auger Fold to Transport

NOTE: Refer to “Troubleshooting” for EOH, vertical auger and/or rotating spout issues in the MAINTENANCE section.

1. To fold auger from operating position to transport position:
 - A. Rotate spout to centered position. Align the checkered flag decals to locate center as shown in Fig. 3-27.
 - B. Press auger FOLD button on joystick.
 - C. Double tap FOLD button until upper auger is on field rest or in transport position.
13. Once unloading is complete, stop hydraulic flow. **ALWAYS** stop continuous detent when auger functions are not required or active.

FIG. 3-27



Cart Loading Sequence

WARNING

- NEVER LOAD THE REAR OF A GRAIN CART FIRST. LOAD THE CART EVENLY TO MAINTAIN WEIGHT ON THE TRACTOR DRAWBAR. LOADING ONLY THE FRONT, OR ONLY THE REAR, CAN CAUSE A LOSS OF CONTROL.
- TIPPING OR MOVEMENT OF THE MACHINE CAN CAUSE SERIOUS INJURY OR DEATH. BE SURE THE MACHINE IS SECURELY BLOCKED.
- UNHITCHING A LOADED CART CAN CAUSE SERIOUS INJURY OR DEATH DUE TO THE TONGUE RISING OR FALLING. ALWAYS HAVE A LOADED CART ATTACHED TO A TRACTOR. THE JACK IS INTENDED TO SUPPORT AN EMPTY CART ONLY.
- NEVER ENTER A CART CONTAINING GRAIN. FLOWING GRAIN TRAPS AND SUFFOCATES VICTIMS IN SECONDS.

1. Ensure auger flow door is closed before loading cart.
2. Fill the cart starting just forward of the axle until nearly full.

NOTE: Overfilling the front or rear area of the hopper can result in reduced control of the cart when towing.

3. Fill the rear area of the hopper before topping off the front area. This maintains proper weight on the hitch of the tractor.

Vertical & Horizontal Cleanout Door Operation

WARNING

- MOVING OR ROTATING COMPONENTS CAN CAUSE SERIOUS INJURY OR DEATH. ENSURE SERVICE COVERS, CHAIN/BELT COVERS AND CLEANOUT DOORS ARE IN PLACE AND SECURELY FASTENED BEFORE OPERATING UNIT.

- KEEP HANDS CLEAR OF PINCH POINT AREAS.

- TIPPING OR MOVEMENT OF THE MACHINE CAN CAUSE SERIOUS INJURY OR DEATH. BE SURE THE MACHINE IS SECURELY BLOCKED.

- EYE PROTECTION AND OTHER APPROPRIATE PERSONAL PROTECTIVE EQUIPMENT MUST BE WORN WHILE SERVICING THE IMPLEMENT.

Closing Vertical Cleanout Door

1. Raise the vertical auger to highest position.
2. Park the empty grain cart on a clean level surface. Block the machine to keep it from moving. Set the tractor's parking brake, shut-off the engine, remove the ignition key and disconnect the PTO shaft.

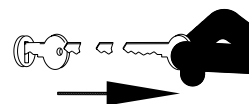

3. To completely close cleanout door, ensure the vertical auger cleanout door top edge clears the vertical position stop (key stop). (FIG. 3-28)
4. Attach eye bolt ends of over center latches to the hooks on the vertical auger. (FIG. 3-28)
5. Clasp the over center latch handles to lock the door in the closed position. (FIG. 3-28)
6. Inspect and verify cleanout door perimeter for gaps. Ensure all grain dust and filings are removed that may prevent the door from shutting completely.
7. If gaps are present, unclasp the over center latch and tighten eye bolt to improve door seal contact on the vertical auger.

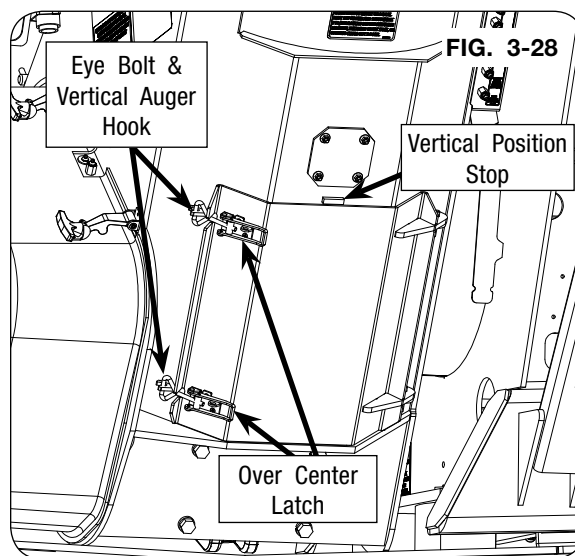

8. Rehook eye bolt to vertical auger and clasp the over center latch.

NOTE: Repeat steps 4 - 8, as necessary.

Vertical & Horizontal Cleanout Door Operation (continued)

Opening Vertical Cleanout Door

1. Raise the vertical auger to highest position.
2. Park the empty grain cart on a clean level surface. Block the machine to keep it from moving. Set the tractor's parking brake, shut-off the engine, remove the ignition key and disconnect the PTO shaft.

NOTE: Remove the vertical auger cleanout door to improve vertical auger cleaning.

3. To open and remove the vertical auger cleanout door, unclasp the over center latch. (FIG. 3-29)
4. Unhook the eye bolt from the vertical auger and open the cleanout door. (FIG. 3-29)

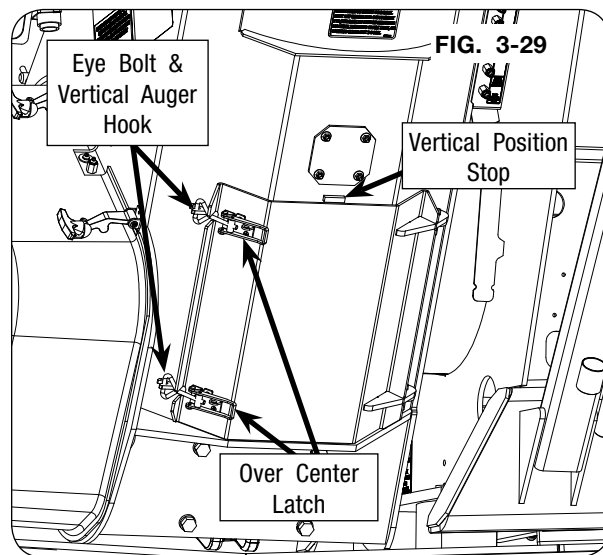
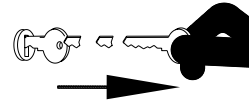

5. The hinge on the vertical auger cleanout door is set on a pin. Lift and remove the cleanout door from the vertical auger. Keep vertical auger cleanout door. (FIG. 3-30)
6. Inspect and verify all debris is removed from inside the vertical auger housing.
7. Reattach the vertical cleanout door to the vertical auger.

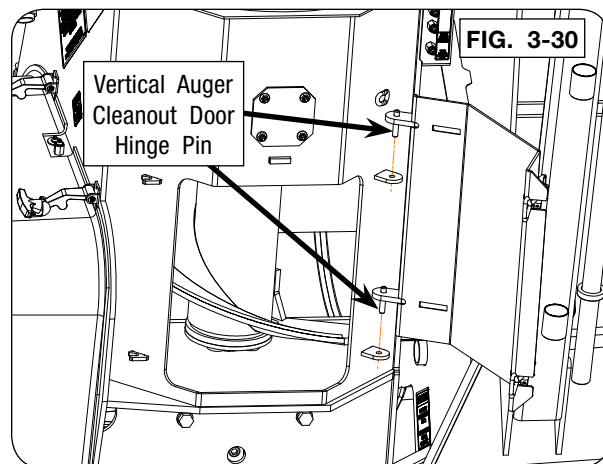

Vertical & Horizontal Cleanout Door Operation (continued)

Horizontal Cleanout Door

Use the tensioner handle, located on the left-hand side of the grain cart, behind the first panel to open and close the horizontal cleanout doors.

1. Park the empty grain cart on a clean level surface. Block the machine to keep it from moving. Set the tractor's parking brake, shut-off the engine, remove the ignition key and disconnect the PTO shaft.

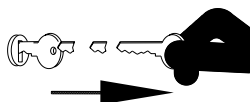

2. Insert tensioner handle into the cleanout door receiver coupler on the rear panel, and remove lynch pin from rockshaft. Keep lynch pin. (FIG. 3-31)

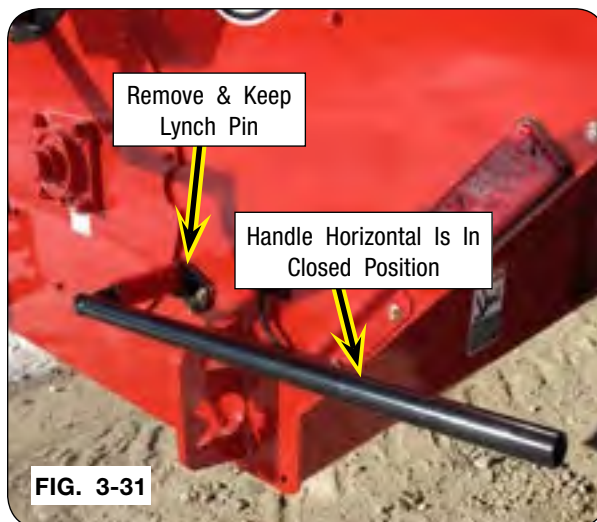

3. Rotate the tensioner handle clockwise to open the cleanout doors. (FIG. 3-32)
4. Insert and lock lynch pin into rockshaft. (FIG. 3-32)

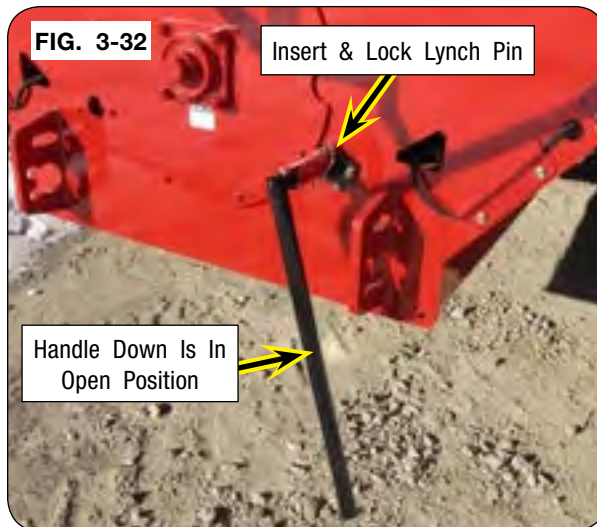

5. Inspect and verify all debris is removed that may prevent the doors from shutting completely. (FIG. 3-33)

NOTE: As the tensioner handle is rotated counter-clockwise near the end of the close position, the coiled springs will extend to apply pressure to cleanout doors. If the doors do not close or visible door perimeter gaps are present, adjust the rockshaft. See “Horizontal Cleanout Door Adjustment” in the MAINTENANCE section.



6. Remove lynch pin from rockshaft and rotate handle counter-clockwise and clockwise to check for smooth door operation.

Vertical & Horizontal Cleanout Door Operation (continued)

Horizontal Cleanout Door

7. Rotate handle counter-clockwise to close doors and ensure all doors seal. (FIG. 3-34)

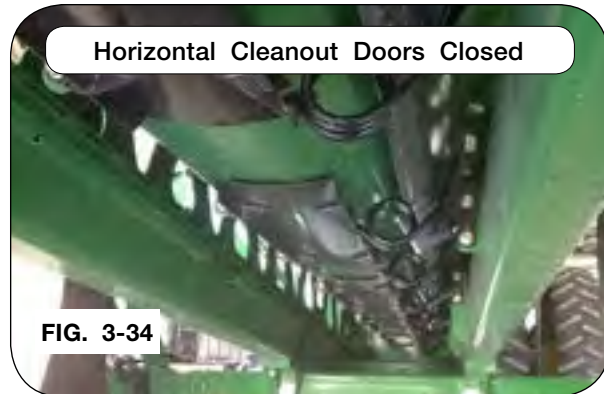

8. Insert and lock lynch pin into rockshaft and return handle to storage location. (FIG. 3-35)

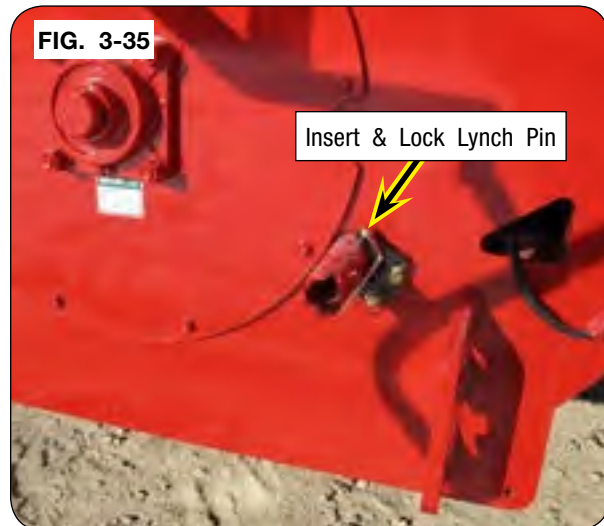

In-Line Tandem

Optional Implement Brake System for In-Line Tandem

This system is for tractors with hydraulic trailer brake option. Once connected and properly bled, this system sends pressure to the implement's brakes when the brake pedal is used. After the brake pedal is released, pressure is removed from the implement calipers. Always check brake operation with an empty cart and familiarize the effectiveness as the load increases in the cart.

Ladder Operation

Side Ladder Operation - For SN B40560100 & Higher

WARNING

- FALLING OR LOWERING EQUIPMENT CAN CAUSE SERIOUS INJURY OR DEATH. KEEP EVERYONE AWAY FROM EQUIPMENT WHEN SUSPENDED, RAISING, OR LOWERING.
- KEEP HANDS CLEAR OF PINCH POINT AREAS.
- DO NOT ALLOW ANYONE TO RIDE ON THE LADDER. MAKE SURE EVERYONE IS CLEAR BEFORE OPERATING MACHINE OR TOWING VEHICLE.
- TO PREVENT PERSONAL INJURY OR DEATH, ALWAYS ENSURE THAT THERE ARE PEOPLE WHO REMAIN OUTSIDE THE CART TO ASSIST THE PERSON WORKING INSIDE, AND THAT ALL SAFE WORKPLACE PRACTICES ARE FOLLOWED. THERE IS RESTRICTED MOBILITY AND LIMITED EXIT PATHS WHEN WORKING INSIDE THE IMPLEMENT.
- NEVER ENTER A CART CONTAINING GRAIN. FLOWING GRAIN TRAPS AND SUFFOCATES VICTIMS IN SECONDS.

NOTE: Ensure ladder and steps are free from snow/debris before changing ladder positions and climbing.

NOTE: Ensure upper ladder extension is attached to higher holes on the ladder. Reference “Upper Side Ladder Extension” section in the SET UP section.

NOTE: Always use lock pin in the working and storage position to lock the ladder extension. The lock pin can be inserted in either left-hand or right-hand ladder hole. (FIG. 3-36 & 3-37)

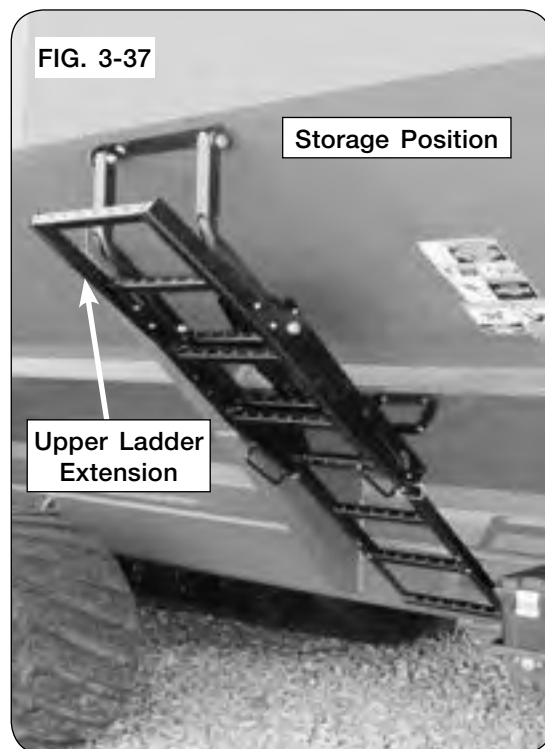

Ladder Operation (continued)

Storage to Working Position

1. Standing in front of ladder, place hands on outside ladder handles.
2. Keep one hand on ladder handle and with opposite hand, remove lock pin from ladder extension. Retain for future use. (FIG. 3-38)
3. With hands back on ladder handles, push ladder towards hopper bin and lift ladder extension to unseat ladder extension rod from the cradle. (FIG. 3-39)



CAUTION

- THE LADDER IS NOW FREE TO PIVOT.

4. Slowly swing ladder outward until hinge is fully extended and locks in the working position. (FIG. 3-40)

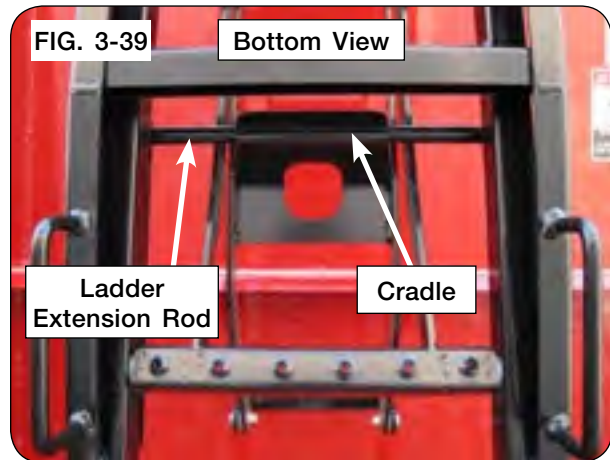
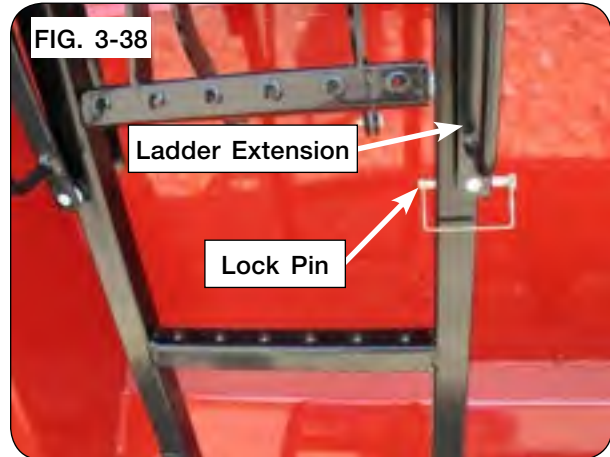

Ladder Operation (continued)

Storage to Working Position

5. Lift and seat ladder extension into shorter leg of “J slot”. (FIG. 3-41)
6. Using lock pin from step 2, insert lock pin into ladder extension and ladder. (FIG. 3-41)

WARNING

- **FALLING FROM AN UNSECURED LADDER MAY CAUSE SERIOUS INJURY OR DEATH. ALWAYS INSERT LOCK PIN BEFORE CLIMBING.**

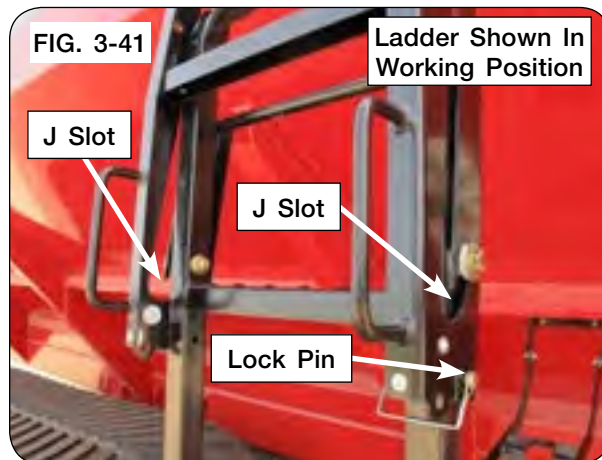

Working to Storage Position

7. Standing in front of ladder, place hands on outside ladder handles.
8. Keep one hand on ladder handle and with opposite hand, remove lock pin from ladder extension. Retain for future use. (FIG. 3-41)
9. With hands back on ladder handles, lift and unseat ladder extension from shorter leg of “J slot”. (FIG. 3-41)
10. Lower ladder extension until fully seated in longer leg of “J slot”. (FIG. 3-42)

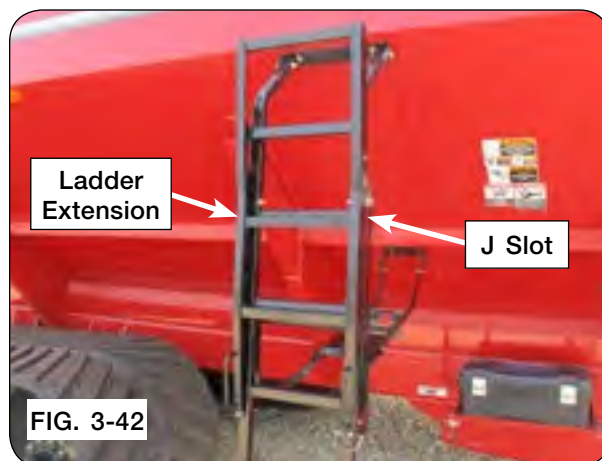

11. Keep one hand on ladder handle and with opposite hand, reach between ladder rungs and grab the ladder hinge hole. (FIG. 3-43)
12. Slowly lift ladder hinge until the ladder starts folding.
13. Remove hand from ladder hinge hole and place onto ladder handle.
14. Slowly push ladder towards hopper bin.



Ladder Operation (continued)

Working to Storage Position

15. Lower ladder extension and seat ladder extension rod onto the cradle. (FIG. 3-44)

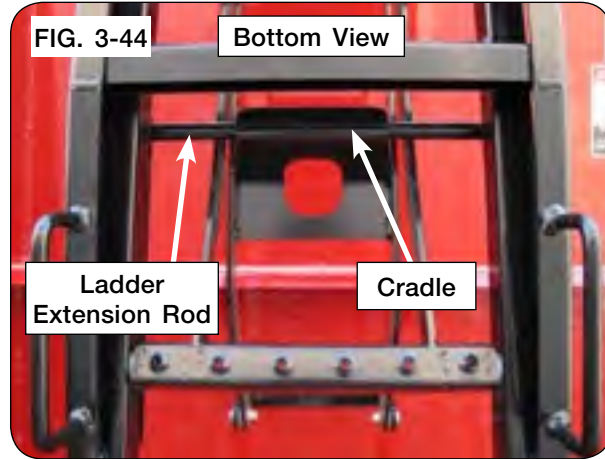

16. Using lock pin from step 8, insert lock pin into ladder extension and ladder. (FIG. 3-45)

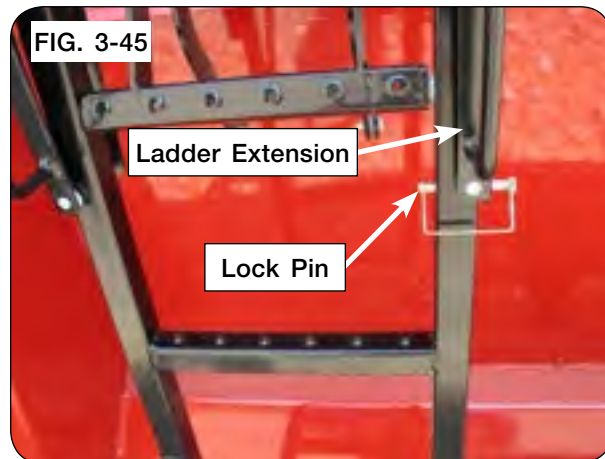

Ladder Operation (continued)

Rear Ladder Operation - For SN B44630100 & Higher

WARNING

- **FALLING OR LOWERING EQUIPMENT CAN CAUSE SERIOUS INJURY OR DEATH. KEEP EVERYONE AWAY FROM EQUIPMENT WHEN SUSPENDED, RAISING, OR LOWERING.**
- **DO NOT ALLOW ANYONE TO RIDE ON THE LADDER. MAKE SURE EVERYONE IS CLEAR BEFORE OPERATING MACHINE OR TOWING VEHICLE.**
- **KEEP HANDS CLEAR OF PINCH POINT AREAS.**
- **TO PREVENT PERSONAL INJURY OR DEATH, ALWAYS ENSURE THAT THERE ARE PEOPLE WHO REMAIN OUTSIDE THE CART TO ASSIST THE PERSON WORKING INSIDE, AND THAT ALL SAFE WORKPLACE PRACTICES ARE FOLLOWED. THERE IS RESTRICTED MOBILITY AND LIMITED EXIT PATHS WHEN WORKING INSIDE THE IMPLEMENT.**
- **NEVER ENTER A CART CONTAINING GRAIN. FLOWING GRAIN TRAPS AND SUFFOCATES VICTIMS IN SECONDS.**

NOTE: Ensure ladder and steps are free from snow/debris before changing ladder positions and climbing.

NOTE: The lower ladder section must be raised and locked in the storage position when not used.

Storage to Working Position

1. Park the empty grain cart on a firm and level surface. Block the machine to keep it from moving. Set the tractor's parking brake, shut-off the engine, remove the ignition key and disconnect the PTO shaft.

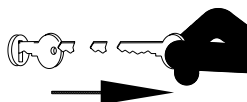

2. While holding ladder handle, remove rubber latch from holder. (FIG. 3-46 and 3-47)
(Continued on next page)

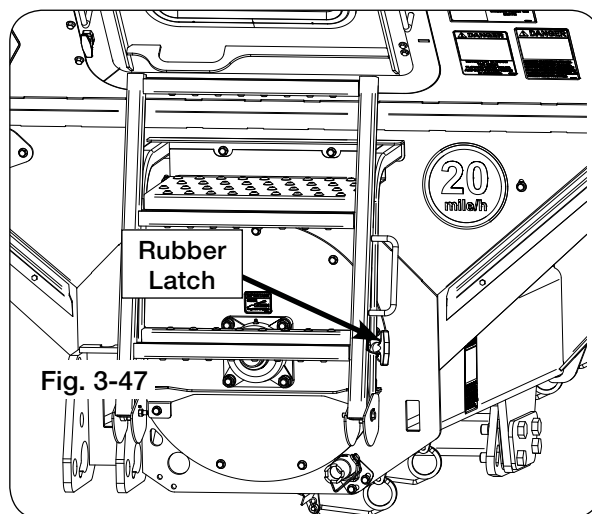
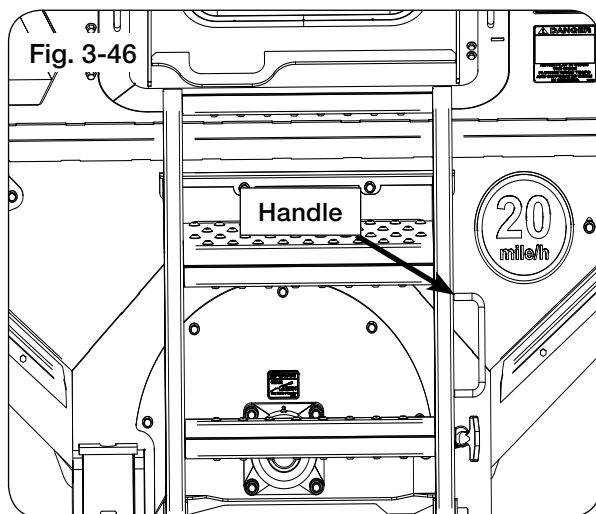

Ladder Operation (continued)

3. While holding ladder handle, slowly swing the lower ladder section completely down to working position. (FIG. 3-48)

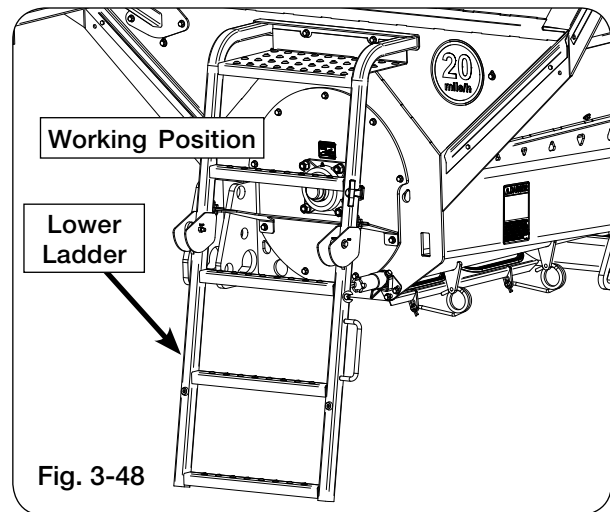

Working to Storage Position

1. Slowly lift and swing the lower ladder section up to storage position. (FIG. 3-49)
2. While holding ladder handle, attach rubber latch into holder to lock ladder in storage position. (FIG. 3-50 and 3-51)

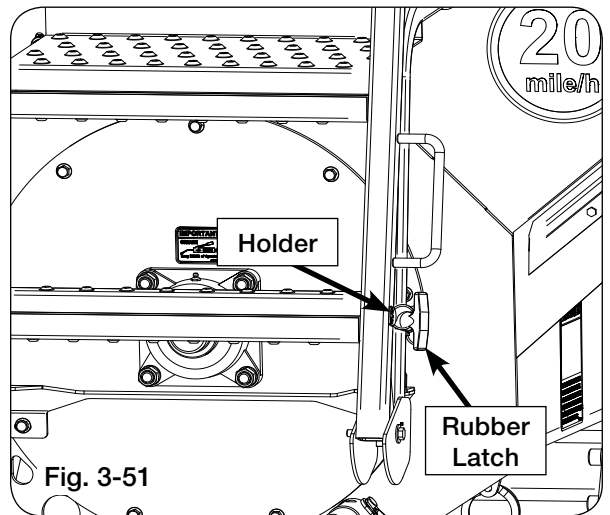
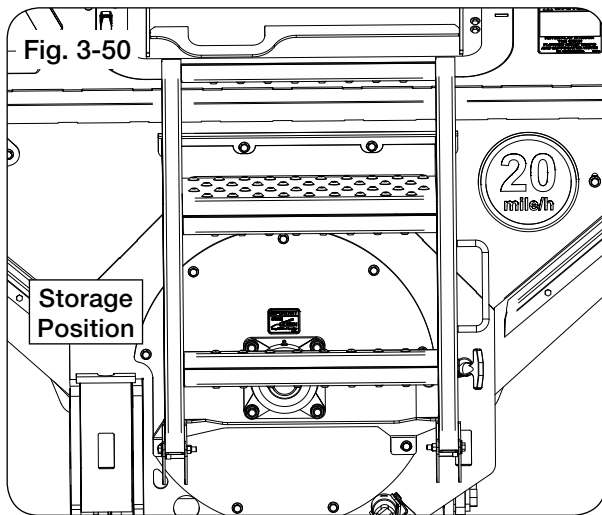
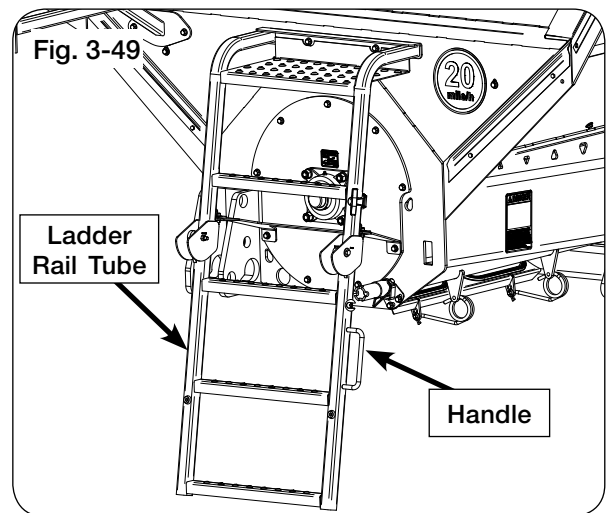

Rear Access Door Operation - For SN B44630100 & Higher

WARNING

- ENSURE SCREENS OVER HORIZONTAL AUGERS ARE IN PLACE AND PROPERLY SECURED.
- TO PREVENT PERSONAL INJURY OR DEATH, ALWAYS ENSURE THAT THERE ARE PEOPLE WHO REMAIN OUTSIDE THE CART TO ASSIST THE PERSON WORKING INSIDE, AND THAT ALL SAFE WORKPLACE PRACTICES ARE FOLLOWED. THERE IS RESTRICTED MOBILITY AND LIMITED EXIT PATHS WHEN WORKING INSIDE THE IMPLEMENT.
- EYE PROTECTION AND OTHER APPROPRIATE PERSONAL PROTECTIVE EQUIPMENT MUST BE WORN WHILE SERVICING THE IMPLEMENT.
- MOVING OR ROTATING COMPONENTS CAN CAUSE SERIOUS INJURY OR DEATH. ENSURE SERVICE COVERS, CHAIN/BELT COVERS AND CLEANOUT DOORS ARE IN PLACE AND SECURELY FASTENED BEFORE OPERATING UNIT.
- KEEP HANDS CLEAR OF PINCH POINT AREAS.
- TIPPING OR MOVEMENT OF THE MACHINE CAN CAUSE SERIOUS INJURY OR DEATH. BE SURE THE MACHINE IS SECURELY BLOCKED.
- NEVER ENTER A CART CONTAINING GRAIN. FLOWING GRAIN TRAPS AND SUFFOCATES VICTIMS IN SECONDS.

1. Park the empty grain cart on a firm and level surface. Block the machine to keep it from moving. Set the tractor's parking brake, shut-off the engine, remove the ignition key and disconnect the PTO shaft.

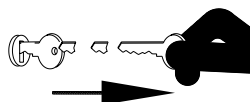

2. Turn both door latches 180 degrees counter clockwise. (Fig. 3-52)
3. Push door handle to open rear access door. (Fig. 3-52)
4. Push door until it stops. While maintaining contact with the outer handles, enter the grain cart. (Fig. 3-52)

(Continued on next page.)

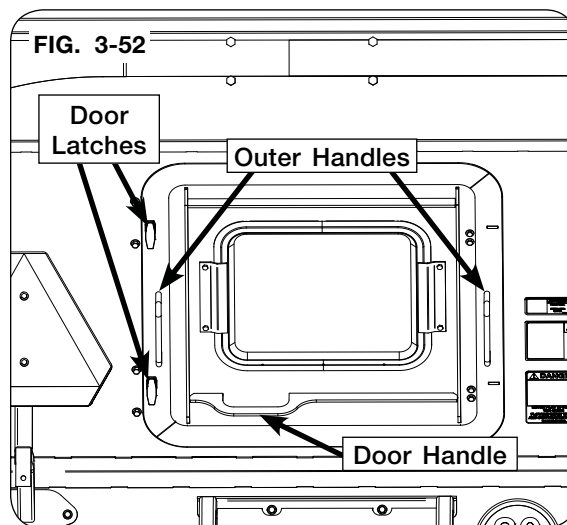

Rear Access Door Operation - For SN B44630100 & Higher

5. To exit, pull inner door handle to open the rear access door, place hand on inner handle and exit grain cart. (Fig. 3-53)

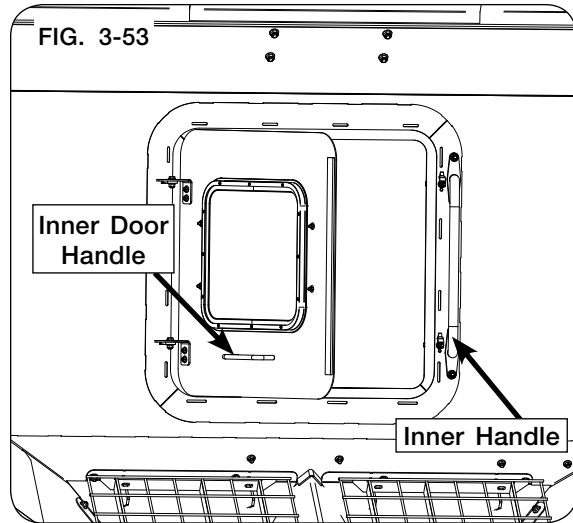

6. While maintaining contact with outer handles, use door handle to close the rear access door. (Fig. 3-54)
7. Turn both door latches 180 degrees clockwise to lock the rear access door. (Fig. 3-54)

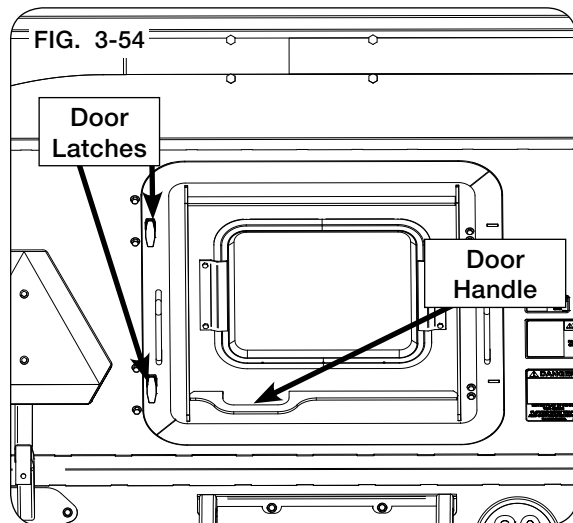

Rear Drop Hitch Operation (Optional)

For SN B44630100 & Higher

WARNING

- KEEP HANDS CLEAR OF PINCH POINT AREAS.
- TIPPING OR MOVEMENT OF THE MACHINE CAN CAUSE SERIOUS INJURY OR DEATH. BE SURE THE MACHINE IS SECURELY BLOCKED.
- EYE PROTECTION AND OTHER APPROPRIATE PERSONAL PROTECTIVE EQUIPMENT MUST BE WORN WHILE SERVICING THE IMPLEMENT.
- FALLING OBJECTS CAN CAUSE SERIOUS INJURY OR DEATH. DO NOT WORK UNDER THE MACHINE AT ANY TIME WHILE BEING HOISTED. BE SURE ALL LIFTING DEVICES AND SUPPORTS ARE RATED FOR THE LOADS BEING HOISTED. THESE ASSEMBLY INSTRUCTIONS WILL REQUIRE SAFE LIFTING DEVICES UP TO 50 LBS. SPECIFIC LOAD RATINGS FOR INDIVIDUAL LOADS WILL BE GIVEN AT THE APPROPRIATE TIME IN THE INSTRUCTIONS.

Storage to Working Position

NOTE: Keep rear drop hitch in storage position when not in use.

1. Park the empty grain cart on a firm and level surface. Block the machine to keep it from moving. Set the tractor's parking brake, shut-off the engine, remove the ignition key.

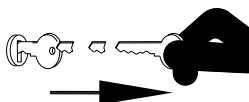

2. Attach a safe lifting device rated for a minimum of 50 lbs. to the rear drop hitch.
3. Remove the keeper from the pivot pin, then remove the pivot pin from the rear drop hitch. (Fig. 3-55)
4. Slowly pivot rear drop hitch to desired position. (Fig. 3-56)
5. Reinstall pivot pin and keeper into rear drop hitch. (Fig. 3-56)

(Continued on next page.)

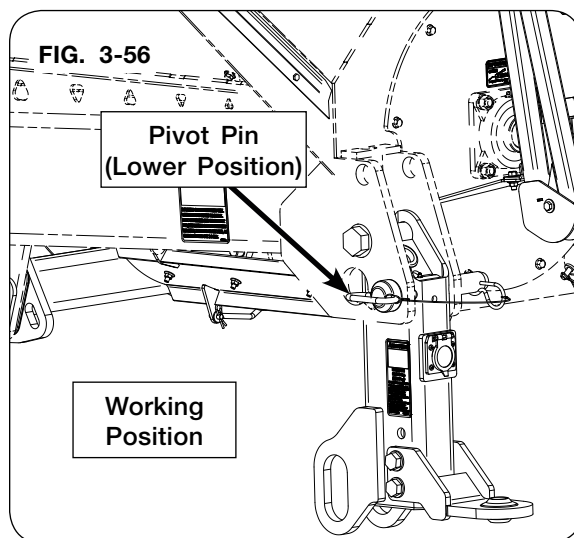
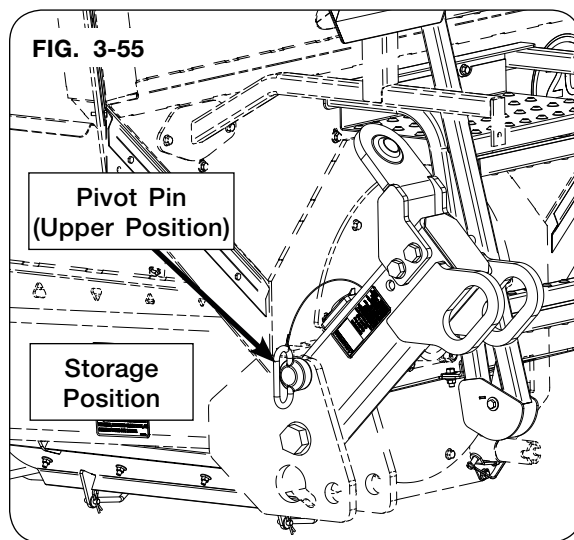

Rear Drop Hitch Operation (Optional) (continued)
For SN B44630100 & Higher

Rear Hitch Connection

IMPORTANT

- The rear ladder **MUST** be folded into storage position to prevent damage when towing with the rear drop hitch.

The transport chain on the grain cart must be sized according to the weight that is being towed. Refer to “Transport Chain” in OPERATION section for complete transport chain instructions.

NOTE: Keep rear drop hitch in storage position when not in use.

1. With hitch in operating position, connect the tongue of the header transport to the rear drop hitch. (Fig. 3-57)
2. If header transport has brakes, attach the brake cable to the rear drop hitch. (Fig. 3-57)
3. Connect transport chains and electrical connection of the header transport to the rear drop hitch. See implement operator’s manual for proper transport chain instructions. (Fig. 3-58)

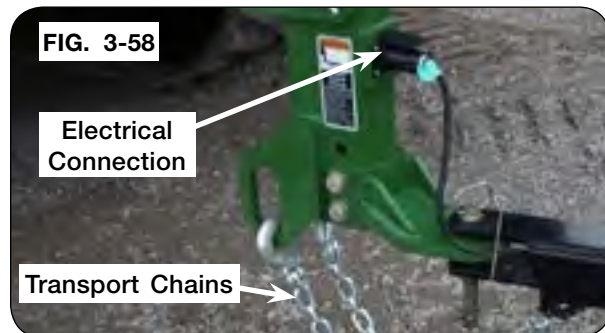
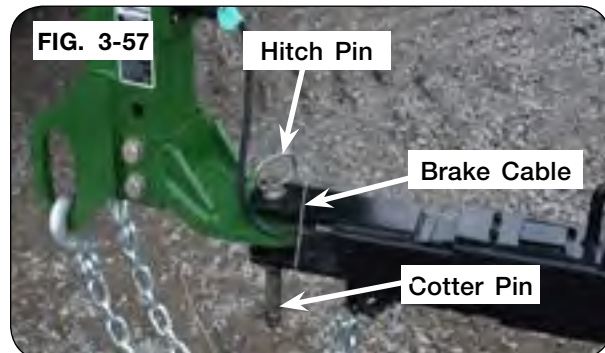

Rear Drop Hitch Operation (Optional) (continued)
For SN B44630100 & Higher

Electrical Connection

The rear drop hitch is equipped with a 7-blade connector which will connect to the plug on most newer header transports to be towed behind the cart. (Fig. 3-59)

The wiring schematic for this connector is shown in the MAINTENANCE section. Verify correct electrical function before using this connector.

Compliance with all lighting and marking laws is the responsibility of the operator at the time of travel.

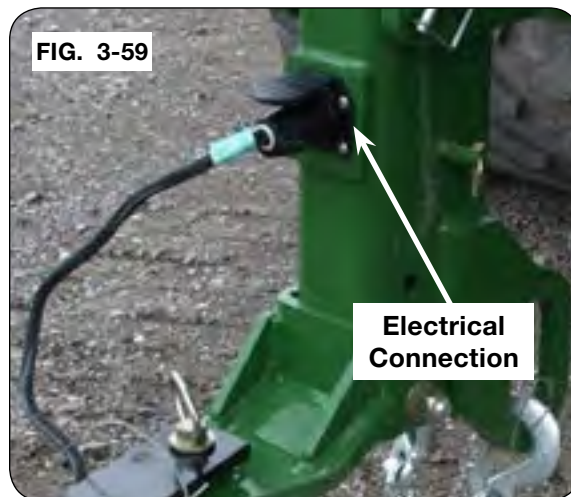

Rear Drop Hitch Operation (Optional)

For SN B44630100 & Higher (continued)

WARNING

- KEEP HANDS CLEAR OF PINCH POINT AREAS.
- TIPPING OR MOVEMENT OF THE MACHINE CAN CAUSE SERIOUS INJURY OR DEATH. BE SURE THE MACHINE IS SECURELY BLOCKED.
- EYE PROTECTION AND OTHER APPROPRIATE PERSONAL PROTECTIVE EQUIPMENT MUST BE WORN WHILE SERVICING THE IMPLEMENT.

Rear Drop Hitch Adjustment

1. Park the empty grain cart on a firm and level surface. Block the machine to keep it from moving. Set the tractor's parking brake, shut-off the engine, remove the ignition key.

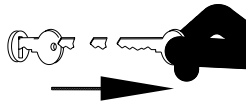

2. Remove the nuts, washers, and bolts from the rear drop hitch.
3. Remove hitch tang and re-install in one of the four positions depending on the height that is needed to maintain a level trailer tongue. There will be a difference of 6 3/4" from position 1 to position 4. (Figs. 3-60 through 3-63)
4. Reinstall the nuts, washers, and bolts to the rear drop hitch and torque to specification.

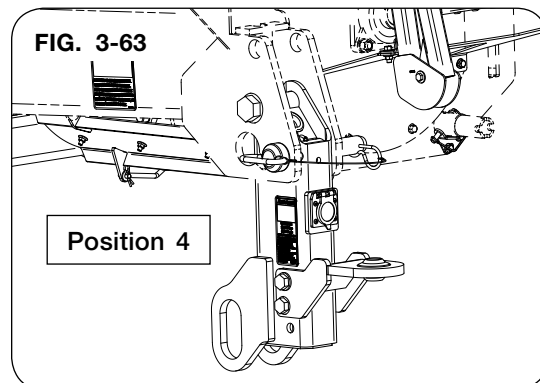
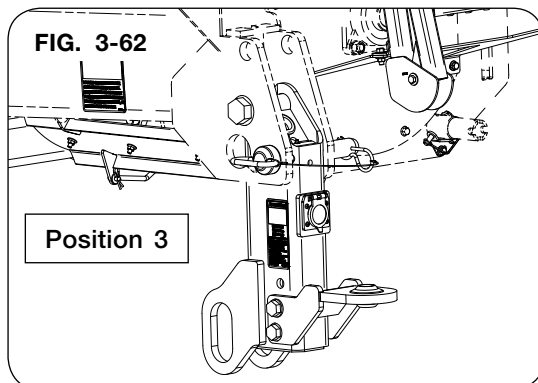
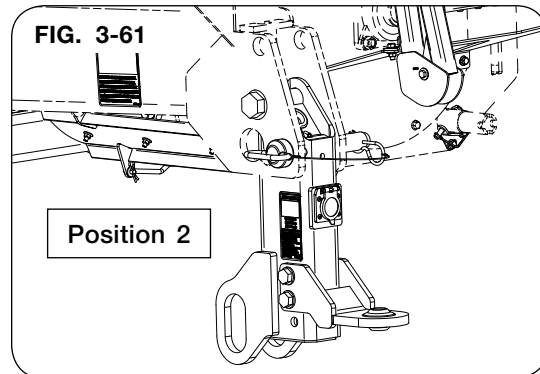
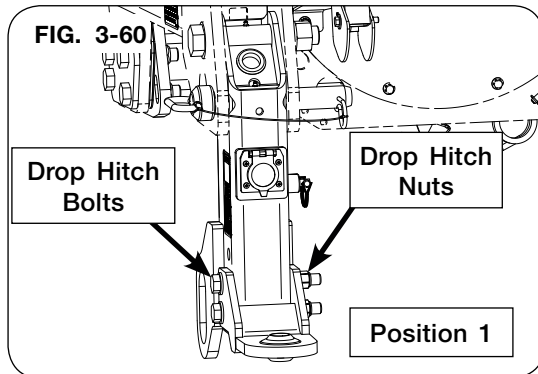

Video System (Optional)

IMPORTANT

- *Do not operate video system below 15°F. Damage to video system can occur.*
- The video system (265770) includes its own operation instruction sheet.

Weather Guard Tarp

WARNING

- **TO PREVENT PERSONAL INJURY OR DEATH, DO NOT ALLOW ANYONE ON A CLOSED TARP. TARP SYSTEM IS NOT DESIGNED TO SUPPORT A PERSON.**
- **FALLING OBJECTS CAN CAUSE SERIOUS INJURY OR DEATH. REMOVE ACCUMULATED WATER/SNOW/ICE OR ANY OTHER OBJECTS FROM TARP BEFORE OPENING TARP.**

IMPORTANT

- *Do not open or close tarp while moving or in high wind conditions. Damage to the tarp may occur.*
- *Tarp should not be used if it is torn or the bungee cords are frayed or show damage. Fully close tarp with tension on the latch plate to prevent water from pooling.*

Always use adequate caution when operating tarp.

If equipped, refer to electric roll tarp manual (26487) for operation details.

Open and close the tarp evenly.

Make sure tarp is open before loading.

Make sure all persons are clear of the tarp system before and during operating.

Do not operate tarp with cart hoisted in an elevated position.

If tarp is covered with snow, it is important to remove snow before operating.

End caps must be free from grain that may be piled on them. Grain should not be heaped higher than the end caps or tarp bows.

Tarp may be fully opened or completely closed while in transit. However, the closed position is recommended.

Ensure everyone who operates the tarp is familiar with the correct procedures outlined in this manual.

Weather Guard Tarp (continued)

NOTE: If equipped with wireless electric roll tarp, skip to next page. For weather guard tarp, continue to step 1.

1. Using both hands, carefully remove tarp handle weldment from tube holder. (FIG. 3-64)
2. Roll tarp to the desired location, choosing either a fully open or fully closed position.
3. To close the tarp, rotate the roll tube clockwise up under the latch plate.
4. Make sure tarp is positioned evenly over latch plate length.

NOTE: Do not tighten if tarp overlaps end of the latch plate. Tearing of the tarp may occur. Reposition tarp, as necessary.

5. Bring the tarp handle weldment down perpendicular to the ground. Continue by lifting it up into the tube holder.

NOTE: Tarp handle weldment U-joint may need to be re-indexed on roll tube to achieve correct tension.

6. To open tarp, turn the roll tube counter clockwise until the tarp is fully open. Place tarp handle weldment in tube holder.

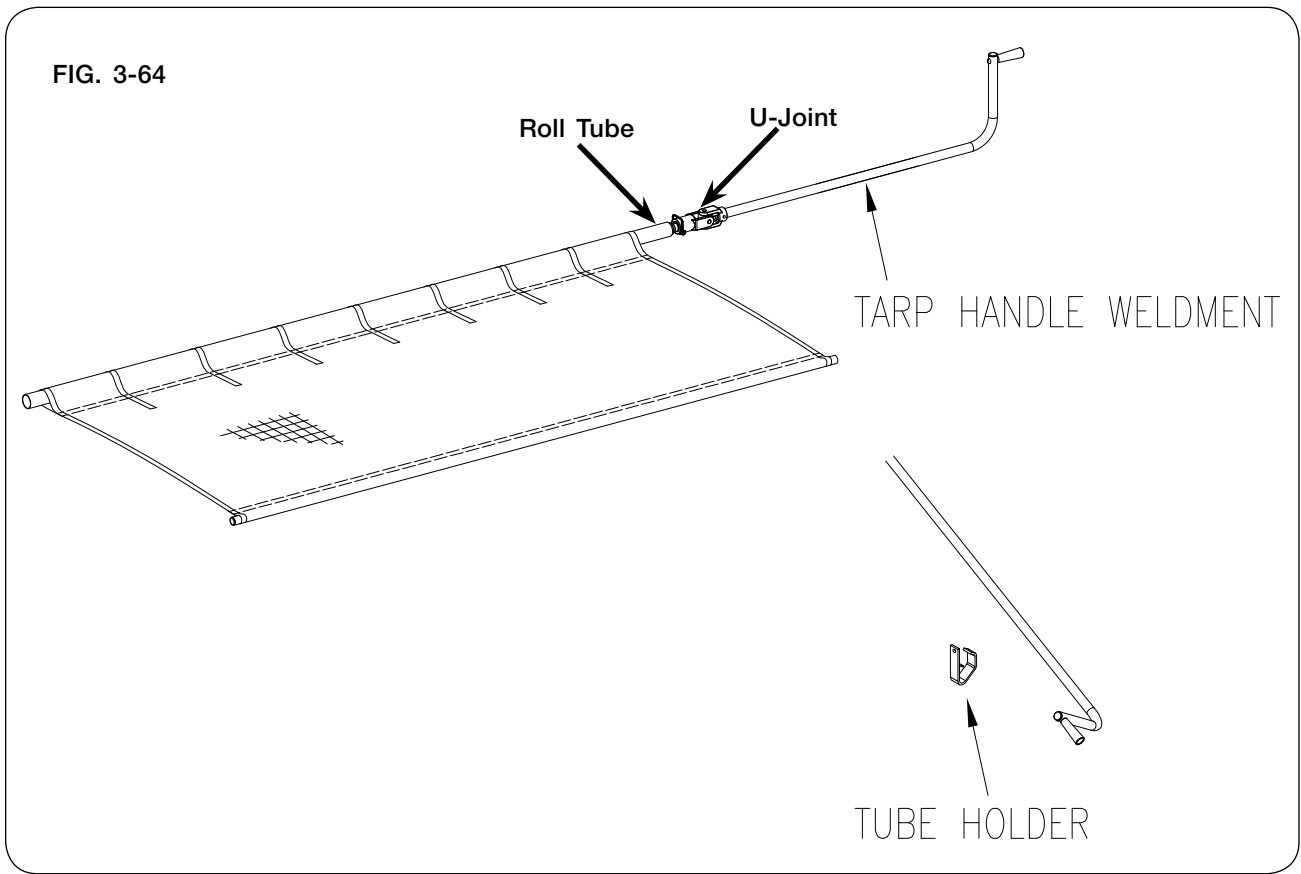

Weather Guard Tarp (continued)

Wireless Receiver and Control Box Location - For SN B43110100 & Higher

NOTE: Refer to electric roll tarp manual (26487) for wireless operation details.

1. Wireless receiver (9009632) and control box (9005398) mount to the left-hand standard behind the vertical auger as shown. (FIGS. 3-65 & 3-66)

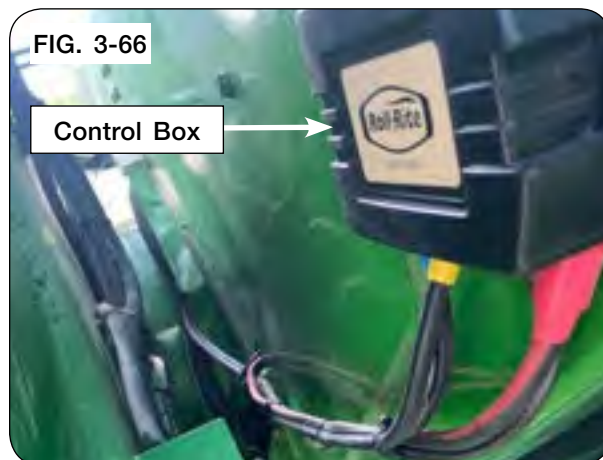

2. Control box wires route along the front of the cart following the isobus harness.
3. Dual connector plug (9005327) attaches to the socket on the back of the tractor as shown. (FIG. 3-67)
4. When electric tarp is not in use, place connector plug into storage caddy. Be sure to route connector plug harness to clear PTO driveline during operation.

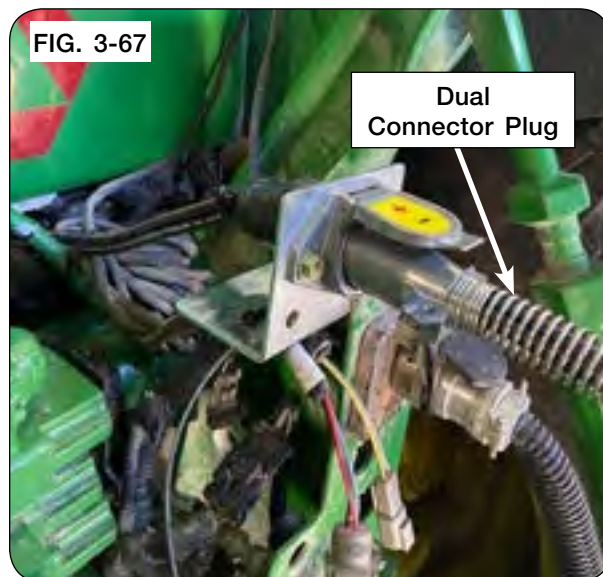

Notes

Section IV Maintenance

Lubrication - Cart.....	4-2
PTO Driveshaft Lubrication - Benzi PTO	4-6
PTO Driveshaft Lubrication - GKN Walterscheid PTO.....	4-7
Hydraulic System.....	4-8
Purge Hydraulic System.....	4-8
Manual Override for Optional Electric Over Hydraulic System.....	4-9
Auger System	
Vertical Auger Height Check.....	4-12
Vertical Auger Folding Linkage Adjustment.....	4-14
Vertical Auger Timing.....	4-15
Horizontal Auger.....	4-16
Horizontal Auger Driveline Bearings.....	4-17
Baffle Adjustment.....	4-18
Horizontal Cleanout Door Adjustment.....	4-20
Belt Tightener Adjustment.....	4-22
V-Belt Alignment.....	4-24
Split Tapered Bushings.....	4-25
Horizontal Auger Removal and Replacement - For SN B40450100 & Higher.....	4-26
Horizontal Auger Removal and Replacement - For SN B40450099 & Lower.....	4-32
Driveline Removal.....	4-37
Gearbox.....	4-37
Verify Telescoping PTO Shaft Length.....	4-38
PTO Shaft Length Adjustment.....	4-40
PTO Shaft & Clutch - Benzi PTO.....	4-41
PTO Shaft & Clutch - GKN Walterscheid PTO.....	4-43
Wheel, Hub and Spindle Disassembly and Assembly.....	4-45
Wheels & Tires	
Wheel Nut Torque Requirements.....	4-47
Tire Pressure.....	4-48
Tire Warranty.....	4-50
Bleeding Procedure for Braking System.....	4-51
Hydraulic Jack Cylinder Replacement.....	4-52
Seasonal Storage.....	4-54
Troubleshooting.....	4-55
Auger Switch Troubleshooting.....	4-57
Tarp Troubleshooting Inspection & Maintenance.....	4-58
Electrical System Diagram.....	4-59
Electrical Diagram.....	4-61
Electrical Over Hydraulic (EOH) System Schematic.....	4-71
Optional Electric Over Hydraulic Valve Electric Schematic 5 Spool.....	4-72
Electrical System Schematic - Optional Wireless Electric Tarp - For SN B43110100 & Higher.....	4-73
Electrical System Schematic - Optional Electric Tarp - For SN B43110099 & Lower.....	4-74
Braking System Schematic.....	4-75
Torque Chart - Hardware Grade 5.....	4-76
Torque Chart - Hardware Grade 8.....	4-77
Hydraulic Fittings - Torque and Installation.....	4-78

FOR SCALE, TRACK, UHARVEST, ELECTRIC TARP, AND / OR WATER DELIVERY SYSTEM
INFORMATION, PLEASE REFER TO THE INDIVIDUAL MANUALS.

Lubrication

To keep your grain cart in top operating condition and to assure its proper performance and reliability for a long period of time, periodic inspection and lubrication is a must.

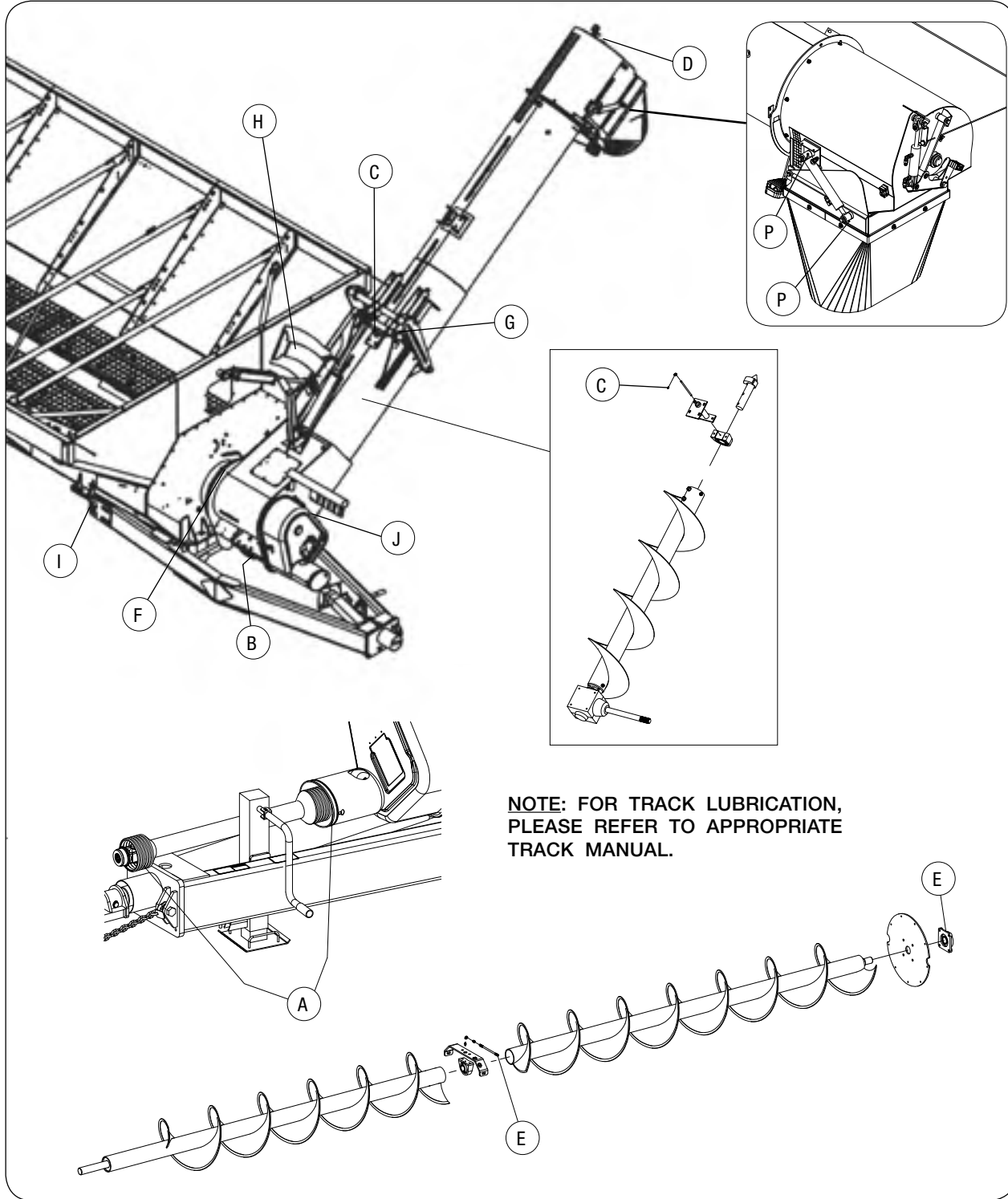

Lubrication (continued)

In-Line Tandem Lubrication Locations

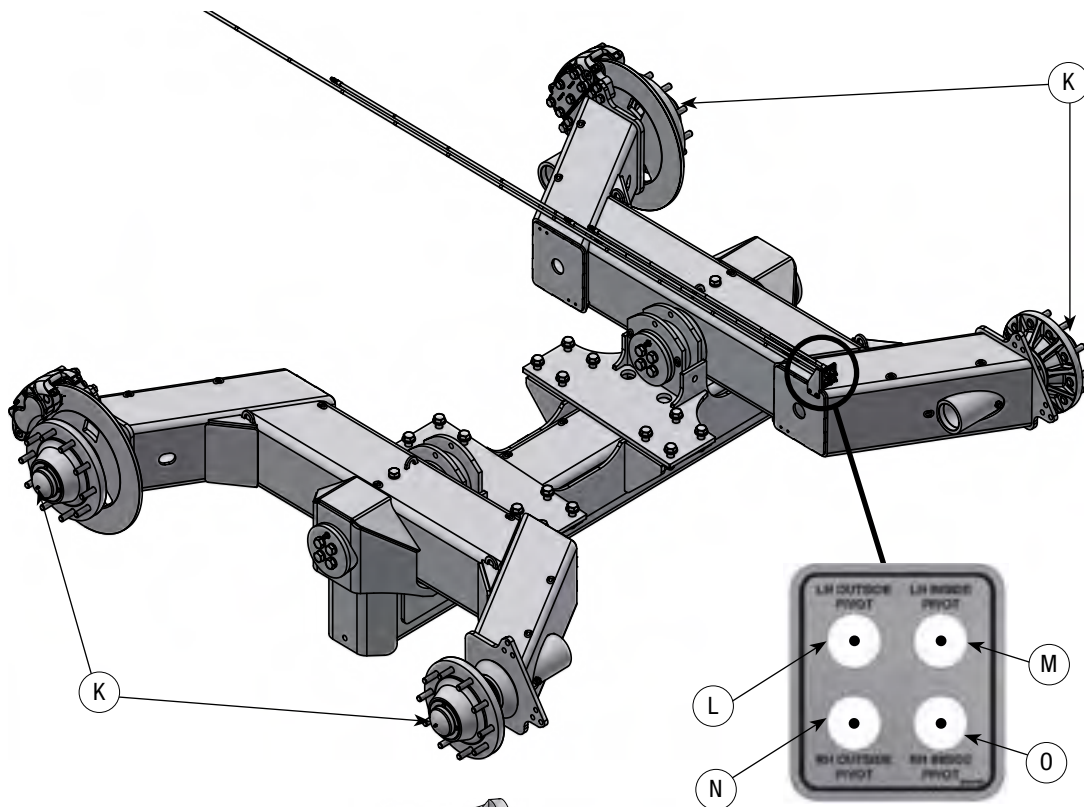

Optional Rear Hitch
For SN B44630100 & Higher

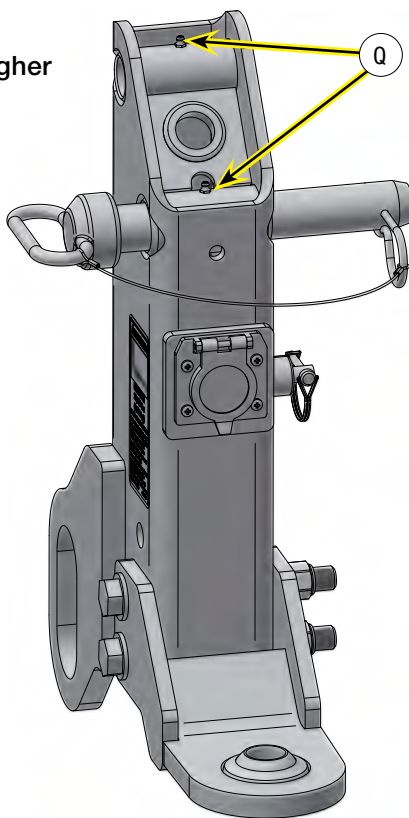

Lubrication (continued)

Lower Auger Pivot Housing Grease Points

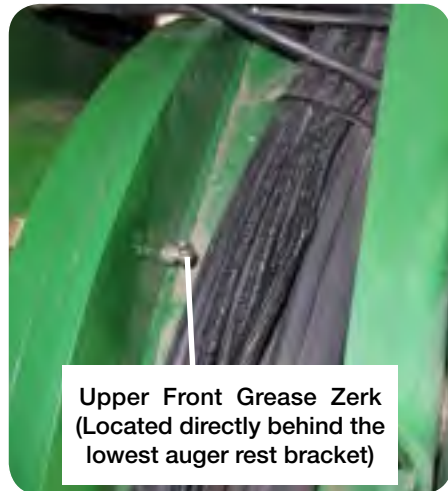
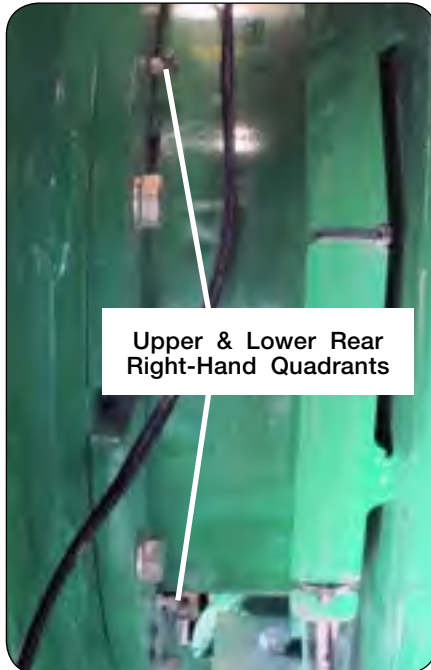

Lubrication (continued)

To keep your grain cart in top operating condition and to assure its proper performance and reliability for a long period of time, periodic inspection and lubrication is a must.

Unverferth Mfg. recommends use of NLGI #2 Extreme Pressure grease.

The lubrication locations and recommended schedule are as follows:

ITEM	DESCRIPTION	POINT	LUBRICANT	QTY.	HOURS
A	PTO Driveshaft - Benzi or GKN Walterscheid	-	EP-2	1 Shot	See Next Pages
B	Gearbox -- Remove Cover - Check oil level every 2 weeks. Replace oil every season. Refer to Gearbox in MAINTENANCE section.	1	EP80W90	Approx 85 oz.	Once Every Season
C*	Hanger Bearing - Vertical Lower Auger See note below*	1	EP-2	2 Shots*	Monthly
D	Top Bearing - Vertical Upper Auger	1	EP-2	1 Shot	Each Season
E	Horizontal Auger End & Center Bearings	2	EP-2	2 Shots	Monthly
F	Auger Pivot Rings - Vertical Lower Auger See previous page for zerk locations.	8	EP-2	2 Shots	Daily
G	Auger Pivot Pin - Vertical Upper Auger	2	EP-2	2 Shots	Daily
H	Grease Slide Plate	1	EP-2	1 Shot	Each Season
I	Tongue Pivot Bushing	2 (one per side)	EP-2	2 Shots	Daily
J	Front Horizontal Auger Bearing & Gearbox Support Bearing	2	EP-2	1 Shot	Weekly
K	Hubs	4	EP-2	Repack	Annually
L	Tandem Grease Bank - LH Outside Pivot	1	EP-2	6 Shots	Daily
M	Tandem Grease Bank - LH Inside Pivot	1	EP-2	6 Shots	Daily
N	Tandem Grease Bank - RH Outside Pivot	1	EP-2	6 Shots	Daily
O	Tandem Grease Bank - RH Inside Pivot	1	EP-2	6 Shots	Daily
P	Spout Tilt Cylinder	2	EP-2	1 Shot	Each Season
Q	Rear Hitch Pivot Pin (Optional) For SN B44630100 & Higher	2	EP-2	2 Shots	Monthly

***NOTE:** Hanger bearing contains hydraulic shut-off grease zerk (9005240) with pressure relief to prevent over-greasing that could push bearing seals out. If grease is coming out of the relief on the zerk, this is normal and the bearing contains enough grease.

PTO Driveshaft Lubrication - Benzi PTO

Lubricate with NLGI grade 2 grease before starting work and every 8 operating hours. Clean and grease PTO driveshaft before each prolonged period of non-use. Molded nipples on the shield near each shield bearing are intended as grease fittings and should be lubricated every 8 hours of operation! Check and grease the guard tubes in winter to prevent freezing.

NOTE: Inner & outer profile tubes must have lubrication to operate successfully regardless of whether a grease fitting is provided for that purpose! Inner & outer profile tubes without fittings should be pulled apart and grease should be added manually.

- Grease the overrunning clutch on front half driveline assembly every 50 operating hours.
- The CAM Cut Out clutch on rear half driveline assembly is pre-greased for 500 operating hours. Contact your dealer for more greasing information.

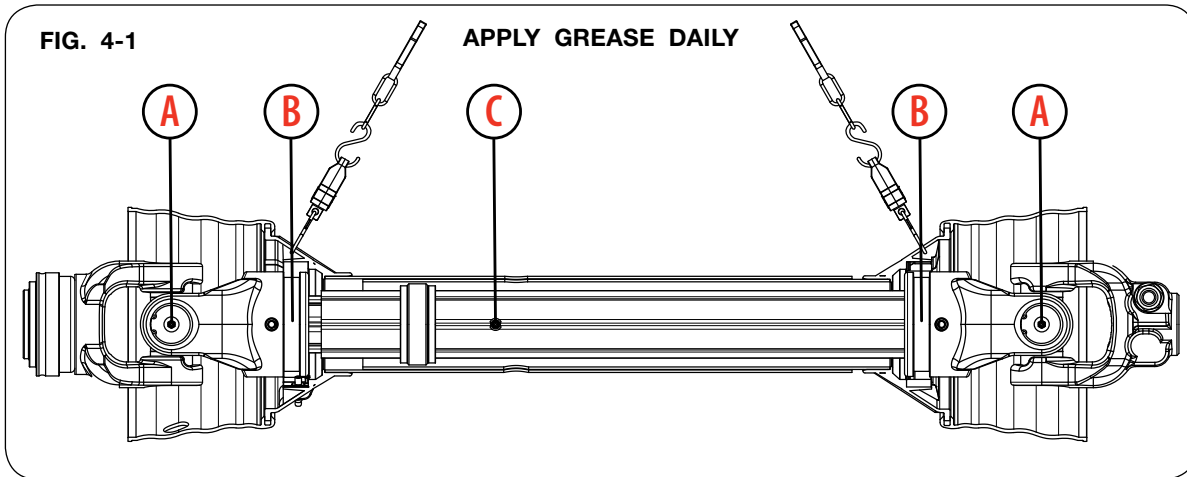

ITEM	DESCRIPTION	POINT	LUBRICANT	QTY.	HOURS
A	U-Joint Cross Kit	1	EP-2	1 Shot	8 Hours
B	Inner & Outer Yoke Groove	1	EP-2	Add Manually	8 Hours
C	Inner & Outer Profile Tube	1	EP-2	Add Manually	Start and End of Each Season

PTO Driveshaft Lubrication - GKN Walterscheid PTO

Lubricate with NLGI grade 2 grease before starting work and every 8 operating hours. Clean and grease PTO driveshaft before each prolonged period of non-use. Molded nipples on the shield near each shield bearing are intended as grease fittings and should be lubricated every 8 hours of operation! Check and grease the guard tubes in winter to prevent freezing.

NOTE: Inner & outer profile tubes must have lubrication to operate successfully regardless of whether a grease fitting is provided for that purpose! Inner & outer profile tubes without fittings should be pulled apart and grease should be added manually.

FIG. 4-2

LUBRICATION INSTRUCTIONS FOR DRIVE LINE

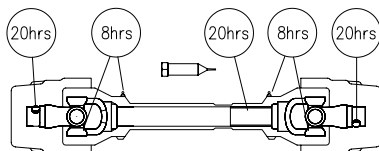

8hrs

20hrs

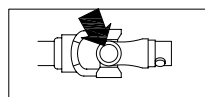

Cross journal

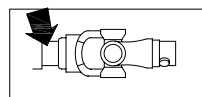

Inner tube

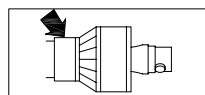

Shield retaining bearing

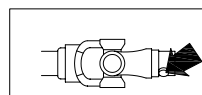

Push-pin set

COAT INNER AND OUTER PROFILES AT BEGINNING AND END OF EACH SEASON

Hydraulic System

Refer to parts section for hydraulic component detail listing.

When properly assembled and maintained, the hydraulic system of the grain cart requires little maintenance.

Replacing Hoses/Fittings/Cylinders:

1. Use replacement hoses, fittings, and cylinders from your Unverferth Manufacturing dealer which are rated for 3000 psi.
2. Do not use hoses, fittings and cylinders that have pipe threads.
3. Do not use Teflon tape or thread sealant on JIC or O-ring fittings. Tighten fittings according to "Torque Chart" in this section.
4. When replacing hoses, always allow sufficient slack to permit hoses to move through the full range of motion of the cylinders.
5. Always purge the hydraulic system after servicing.

Purge Hydraulic System

WARNING

- **HYDRAULIC SYSTEM MUST BE PURGED OF AIR BEFORE OPERATING TO PREVENT SERIOUS INJURY OR DEATH.**

- **RELIEVE HYDRAULIC SYSTEM OF ALL PRESSURE BEFORE ADJUSTING OR SERVICING. SEE THE HYDRAULIC POWER UNIT OPERATOR'S MANUAL FOR PROPER PROCEDURES.**

- **HIGH-PRESSURE FLUIDS CAN PENETRATE THE SKIN AND CAUSE SERIOUS INJURY OR DEATH. LEAKS OF HIGH-PRESSURE FLUIDS MAY NOT BE VISIBLE. USE CARDBOARD OR WOOD TO DETECT LEAKS IN THE HYDRAULIC SYSTEM. SEEK MEDICAL TREATMENT IMMEDIATELY IF INJURED BY HIGH-PRESSURE FLUIDS.** 

- **KEEP CLEAR OF PINCH POINT AREAS.** 

Purge air from system as follows:

- A. Clear all personnel and objects from the area, including where the machine will have full range of motion during the hydraulic movement. Remove transport locks from the machine.
- B. Pressurize the system and maintain system at full pressure for at least 5 seconds after cylinder rods stop moving, or hydraulic motors have completed the required movement. Check that all movements are fully completed.
- C. Check oil reservoir in hydraulic power source and refill as needed.
- D. Pressurize system again to reverse the motion of step B. Maintain pressure on system for at least 5 seconds after cylinder rods stop moving, or hydraulic motors have completed the required movement. Check that all movements are fully completed.
- E. Check for hydraulic leaks using cardboard or wood. Tighten connections according to directions in Torque Chart in this section.
- F. Repeat steps B, C, D, and E 10-12 times.

IMPORTANT

- *Machine damage will occur if the cylinder is incorrectly installed.*

Check for and correct any leaks. Make sure hoses are not kinked, stretched, or twisted. Secure hoses to prevent cuts or chafing during operation.

Manual Override for Optional Electric Over Hydraulic System

⚠ WARNING

- MOVING OR ROTATING AUGER COMPONENTS CAN CAUSE SERIOUS INJURY OR MACHINE DAMAGE. BEFORE OPERATING MANUAL OVERRIDE(S), ENSURE EVERYONE IS AWAY FROM THE SPOUT AND THAT THE SPOUT WILL NOT CONTACT ANY OTHER PARTS OF THE GRAIN CART. ALL CONTROL SWITCHES ARE DEACTIVATED WHILE UTILIZING MANUAL OVERRIDE(S).
- MOVING OR ROTATING PTO COMPONENTS CAN CAUSE SERIOUS INJURY OR DEATH. DO NOT OPERATE PTO WHILE UTILIZING MANUAL OVERRIDE(S).
- FALLING OR LOWERING EQUIPMENT CAN CAUSE SERIOUS INJURY OR DEATH. KEEP EVERYONE AWAY FROM EQUIPMENT WHEN SUSPENDED, RASING, OR LOWERING.

IMPORTANT

- Spout must be centered before operating the auger fold. Align checker flag decals to ensure spout rotate is centered.

NOTE: Manual override operation is intended for emergency use ONLY and is not intended for continuous operation. Spout may rotate into cart causing damage.

NOTE: Manual override operation allows the spout and auger to move regardless of location.

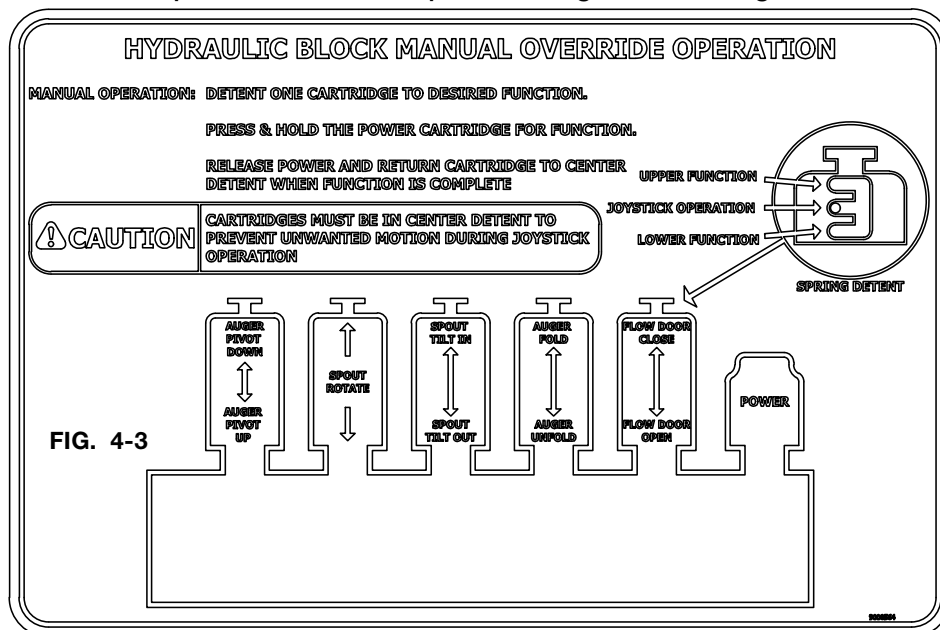

1. Park the grain cart on a firm and level surface. Block the machine to keep it from moving. Set the tractor's parking brake. Keep engine running.

Manual Override for Optional Electric Over Hydraulic System (continued)

2. Remove cover plate (272606B) from the bottom of the lower auger housing to access the EOH block assembly. Keep cover plate. (FIG. 4-4)
3. Connect the desired Hydraulic Pressure and Return hoses to the tractor SCV remote so that the Pressure line is able to be put in continuous detent.
4. To operate the manual override function, place the tractor SCV remote in continuous detent so that the Hydraulic Pressure hose is pressurized.

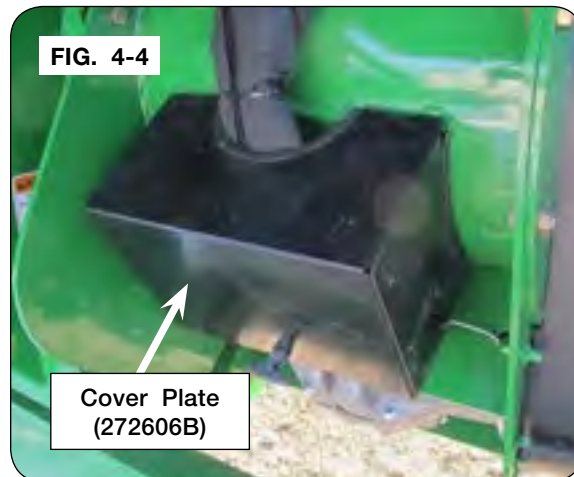

Manual Override for Optional Electric Over Hydraulic System (continued)

NOTE: Only one cartridge valve (9008416 & 9008463) must be in the top or bottom detent position at a time to function properly. All other valves must be in the middle detent position. (FIG. 4-5 & 4-6)

5. Operate the desired function on valve (9008416 & 9008463) by rotating the manual override knurled knob from the locked neutral position. (FIG. 4-5, 4-6, & 4-8)
6. Push and hold the manual override button on valve (9008438). (FIG. 4-7)
7. Once the desired position is reached, release manual override button on valve (9008438).
8. Return knurled knob to center and lock valve (9008416) & (9008463) in position. (FIG 4-5, 4-6 & 4-8)

NOTE: Refer to “Troubleshooting” for EOH, vertical auger and/or rotating spout issues in the MAINTENANCE section.

9. Turn off hydraulic circuit when done. Correct electric/hydraulic system before continued use. Consult your dealer for service and parts.
10. Place cover plate (272606B) from step 2 back onto the bottom of the lower auger housing.

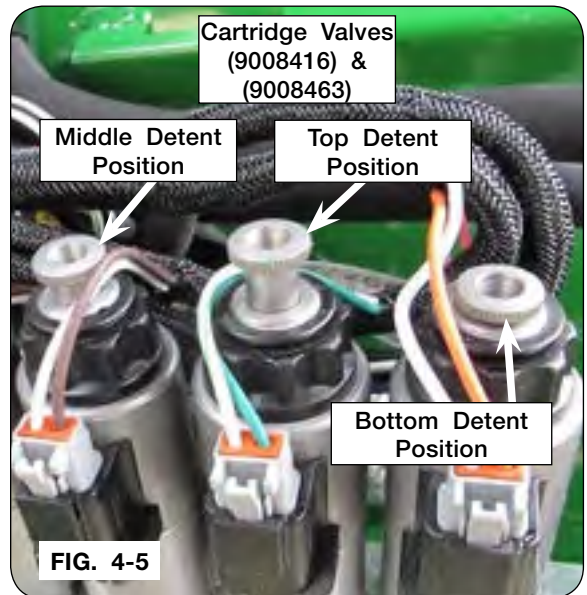

FIG. 4-5

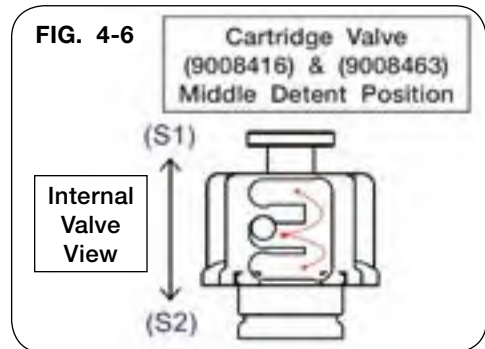

FIG. 4-6



FIG. 4-8

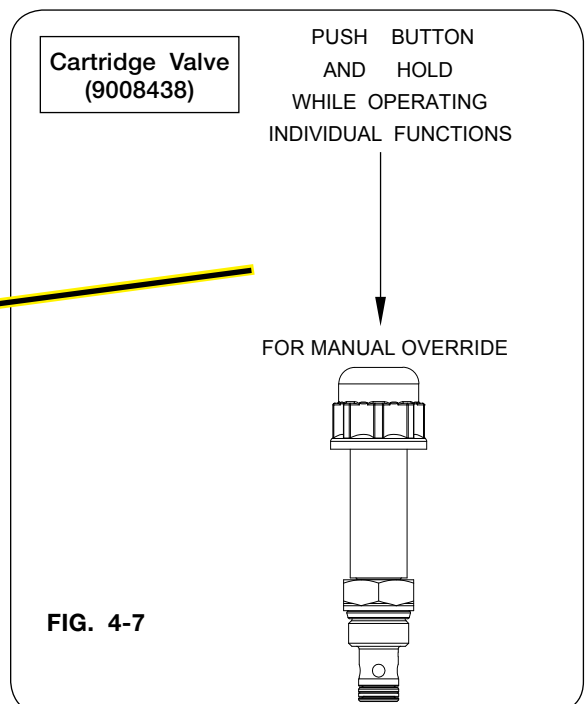

FIG. 4-7

Auger System

WARNING

- TO PREVENT PERSONAL INJURY OR DEATH, ALWAYS ENSURE THAT THERE ARE PEOPLE WHO REMAIN OUTSIDE THE CART TO ASSIST THE PERSON WORKING INSIDE, AND THAT ALL SAFE WORKPLACE PRACTICES ARE FOLLOWED. THERE IS RESTRICTED MOBILITY AND LIMITED EXIT PATHS WHEN WORKING INSIDE THE IMPLEMENT.
- NEVER ENTER CART WITH AUGER OR TRACTOR RUNNING. SERIOUS OR FATAL INJURY CAN OCCUR DUE TO ENTANGLEMENT WITH ROTATING COMPONENTS. ALWAYS STOP ENGINE AND REMOVE KEY BEFORE ENTERING CART.
- KEEP HANDS CLEAR OF PINCH POINT AREAS.
- EYE PROTECTION AND OTHER APPROPRIATE PERSONAL PROTECTIVE EQUIPMENT MUST BE WORN WHILE SERVICING IMPLEMENT.
- FALLING OBJECTS CAN CAUSE SERIOUS INJURY OR DEATH. DO NOT WORK UNDER THE MACHINE AT ANY TIME WHILE BEING HOISTED. BE SURE ALL LIFTING DEVICES AND SUPPORTS ARE RATED FOR THE LOADS BEING HOISTED. THESE ASSEMBLY INSTRUCTIONS WILL REQUIRE SAFE LIFTING DEVICES UP TO 2,000 LBS. SPECIFIC LOAD RATINGS FOR INDIVIDUAL LOADS WILL BE GIVEN AT THE APPROPRIATE TIME IN THE INSTRUCTIONS.
- MOVING OR ROTATING COMPONENTS CAN CAUSE SERIOUS INJURY OR DEATH. ALWAYS DISCONNECT POWER SOURCE BEFORE SERVICING. ENSURE SERVICE COVERS, CHAIN/BELT COVERS AND CLEAN-OUT DOOR(S) ARE IN PLACE AND SECURELY FASTENED BEFORE OPERATING MACHINE.
- WHEN WORKING AROUND THE IMPLEMENT, BE CAREFUL NOT TO BE CUT BY SHARP EDGES.



Vertical Auger Height Check

Before servicing the vertical auger, park the unit on a firm, level surface. Block the machine to keep it from moving. Raise vertical auger to discharge position and close horizontal auger flow door. Set the tractor parking brake, turn off tractor engine, remove ignition key, and disconnect PTO shaft and hydraulic lines from tractor.

Annually check all bolts, nuts, and set screws for tightness. Replace the vertical auger top bearing hardware, as necessary. (FIG. 4-9)

Loosen Bearing Setscrews
To Change Upper Auger
Position In Tube. Retighten
Setscrews.

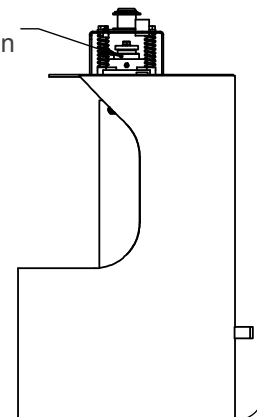

FIG. 4-9

Auger System (continued)

Vertical Auger Height Check (continued)

NOTE: The lower auger position is indexed from the drive dog / tube flange hinge surface as shown. (Figs. 4-11 & 4-12)

Fig. 4-12

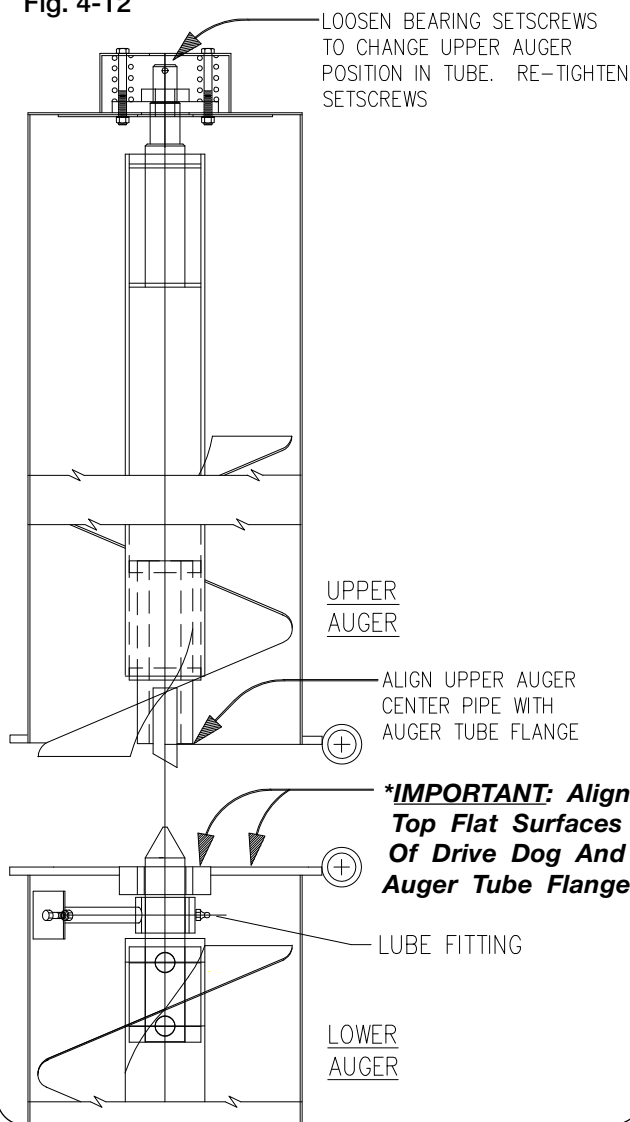

Fig. 4-10

Align Upper Auger Center Pipe With Auger Tube Flange

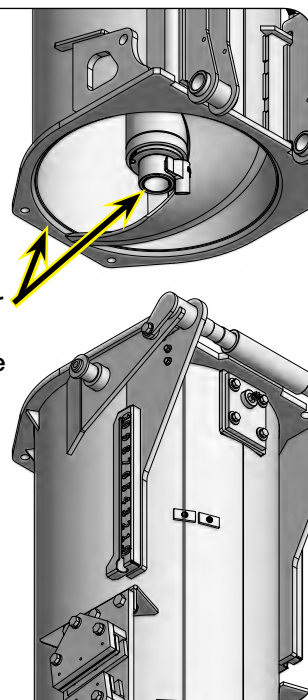
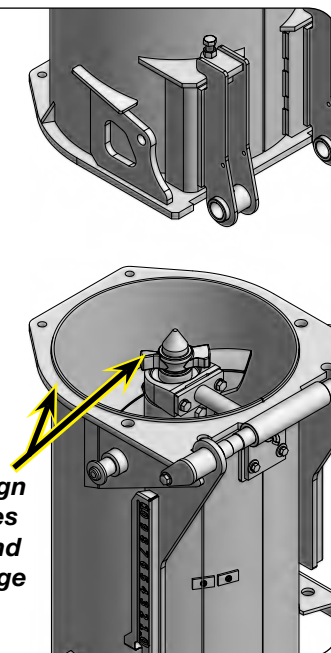

Fig. 4-11

***IMPORTANT: Align Top Flat Surfaces Of Drive Dog And Auger Tube Flange**



Auger System (continued)

Vertical Auger Folding Linkage Adjustment

NOTE: To fold auger from operating position to transport position, refer to “Electric Over Hydraulic Operation (Optional)” in the OPERATION section.

1. Before adjusting the vertical auger folding linkage, park the unit on a firm, level surface. Block the wheels/tracks to keep the machine from moving. Set the tractor parking brake, turn off tractor engine, remove ignition key, and disconnect PTO shaft and hydraulic lines from tractor.



NOTE: The starting distance for the folding linkage pin center-to-center is 13 3/4". (FIG. 4-13)

2. At the FRONT of the auger, remove retaining rings (91192) from the pin (272587) on clevis (9006491). Keep retaining rings and pin. (FIG. 4-13)
3. Adjust the folding linkage until the center-of-pin to center-of-pin measurement is 13 3/4". (FIG. 4-13)
4. Reinsert pin into clevis and attach retaining rings to pin.
5. Repeat procedure for the folding linkage on the BACK of the auger.
6. Reattach PTO. Refer to “Driveline Installation” in SET UP section.
7. Reconnect hydraulic lines to tractor. Refer to “Hitching to Tractor” in OPERATION section.
8. Choose an area free from obstructions and unfold auger to operating position. Allow sufficient time for the cylinder to fully engage the two augers and over-center latch to fully engage.
9. Verify the upper auger picture frame is flush against the lower auger picture frame.

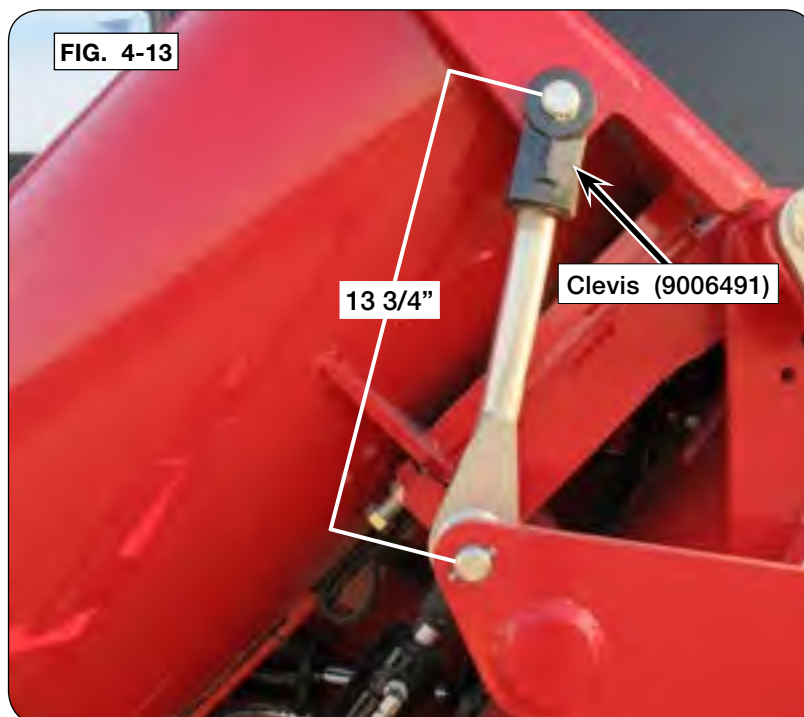

Auger System (continued)

Vertical Auger Timing

1. For the lower vertical auger, use the top edge of the flighting as a 12 o'clock reference. Position the drive dog so the driving edge is at the 11 o'clock position. (FIG. 4-14)

NOTE: Looking down at the lower flighting (FIG. 4-14) the auger rotation will be counter-clockwise. When looking up at the upper flighting (FIG. 4-15) the auger rotation will be clockwise.

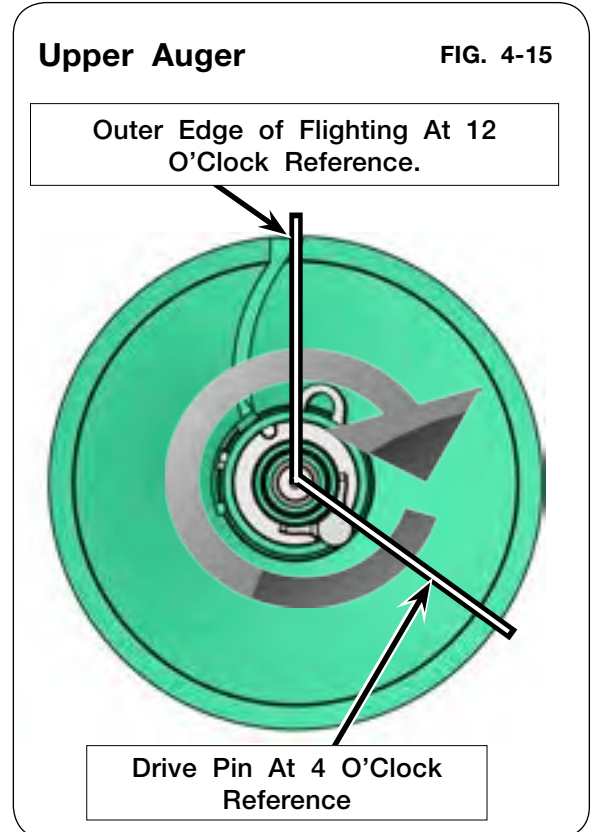
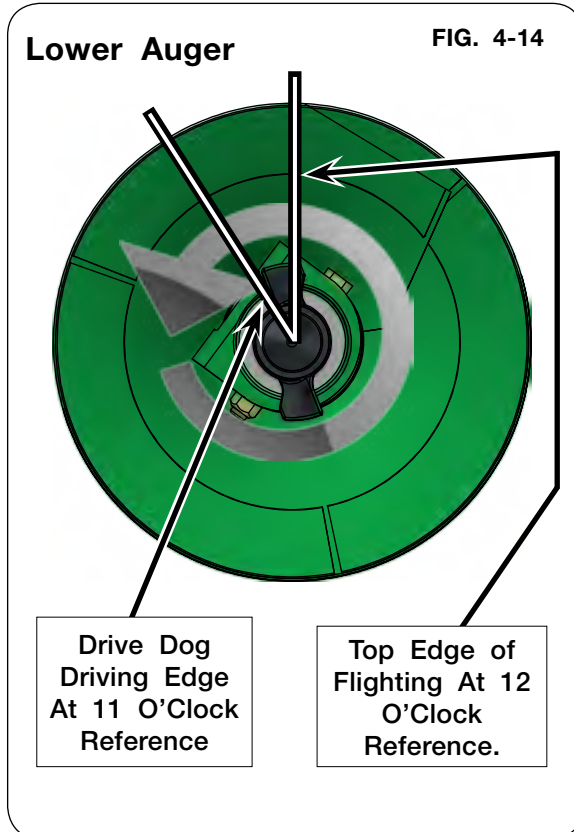

2. For the upper auger, use the outer edge of the flighting as a 12 o'clock reference. Position the driven edge of the drive pin at the 4 o'clock position. (FIG. 4-15)
3. When engaged, the upper flighting should follow the lower flighting. (FIG. 4-16)

NOTE: Upper flighting should trail the lower flighting from minimum of 10 degrees to a maximum of 90 degrees.

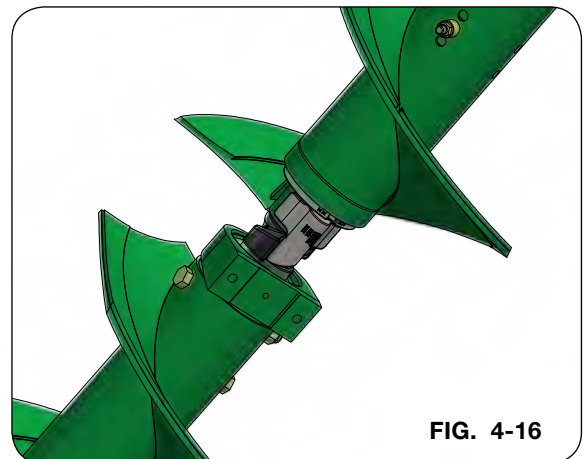

Auger System (continued)

Horizontal Auger

Annually check all bolts, nuts, and set screws. Perform lubrication as specified in “Lubrication” section.

NOTE: With new flighting, the outside diameter is about 3/4” from the bottom belly pan. Always set bearing height using the flighting centerline measurement. See FIG. 4-17.

NOTE: Shims (286424B) are available from your Parker dealer to achieve 10 1/8” measurement.

To adjust the bearing height down, shim with washers between the bearing and the hanger bracket. To adjust the bearing height up, shim with washers between the bearing bracket and the sides of the cart. When adjusting the height up, washers will need to be placed with one on each side so the bearing stays centered.

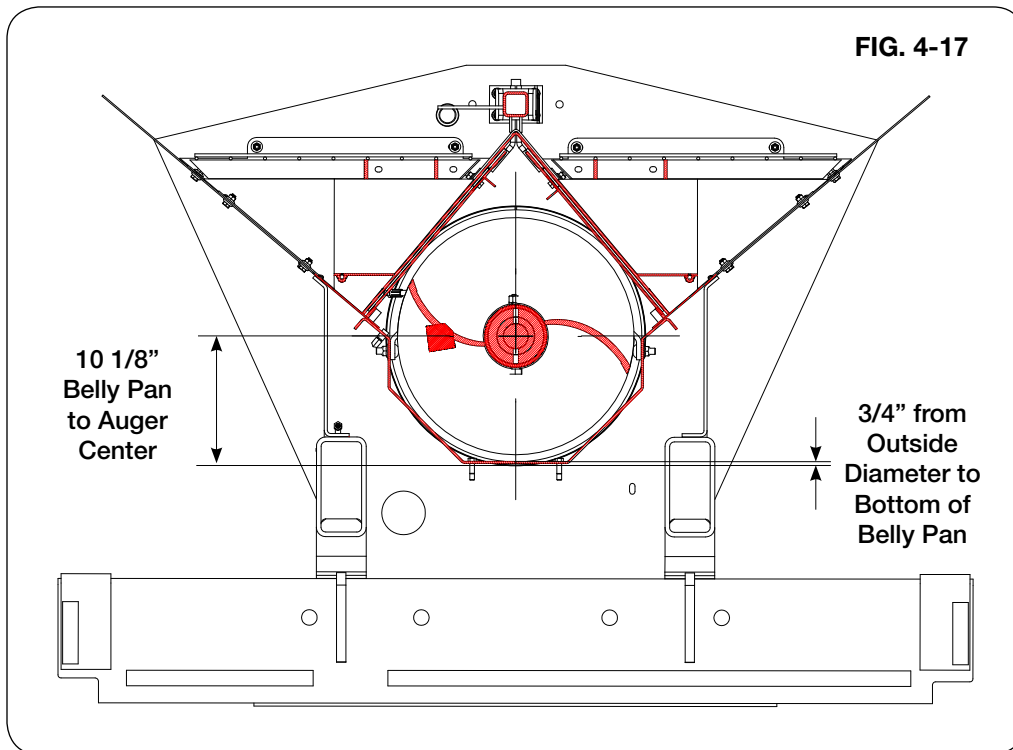

Auger System (continued)

Horizontal Auger Driveline Bearings

IMPORTANT

- Periodically check set screws in all bearings at either end of the driveline for tightness. (FIGS. 4-18 & 4-19)

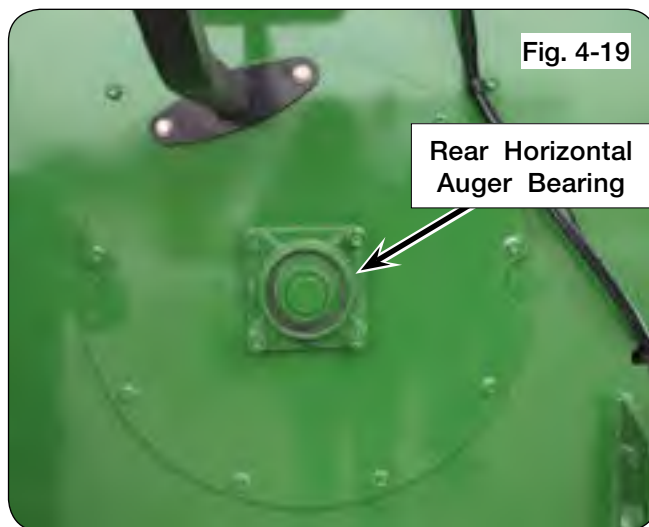

Baffle Adjustment

WARNING

- TO PREVENT PERSONAL INJURY OR DEATH, ALWAYS ENSURE THAT THERE ARE PEOPLE WHO REMAIN OUTSIDE THE CART TO ASSIST THE PERSON WORKING INSIDE THE CART, AND THAT ALL SAFE WORKPLACE PRACTICES ARE FOLLOWED. THERE IS RESTRICTED MOBILITY AND LIMITED EXIT PATHS WHEN WORKING INSIDE THE CART.
- NEVER ENTER CART WITH AUGER OR TRACTOR RUNNING. SERIOUS OR FATAL INJURY CAN OCCUR DUE TO ENTANGLEMENT WITH ROTATING COMPONENTS. ALWAYS STOP ENGINE AND REMOVE KEY BEFORE ENTERING CART.

The horizontal auger baffles are factory-set at the lowest position. This position results in the lowest power requirements and longest flighting life. Once grain has been run through the unit, adjustments can be made to achieve the ideal unloading performance.

Refer to the following reasons for baffle adjustment:

NOTE: To unload the cart evenly from front to back the openings should increase in height from back to front.

- If higher flow is desired and torque is not the limiting factor, raise each baffle to an incremental amount and rerun.
- If more material remains at the back of the cart towards the end of the unloading cycle, the back baffles should be adjusted upward in incremental amounts and rerun.
- If more material remains at the front of the cart towards the end of the unloading cycle, the back baffles should be adjusted downward in incremental amounts and rerun.
- If the cart requires more torque than what is available at times during the unloading cycle, then all baffles should be adjusted downward in incremental amounts.

Baffle Adjustment (continued)

The horizontal auger baffles are factory-set at the lowest position. This position results in the lowest power requirements and longest flighting life. Once grain has been run through the unit, adjustments can be made to achieve the ideal unloading performance.

Before making any baffle adjustments, close horizontal auger flow door. Securely block the grain cart. Set the tractor parking brake, turn off tractor engine, remove ignition key, and disconnect PTO.

If a higher flow is desired and torque is not a factor, loosen the (2) flange nuts on each baffle, see figure 4-20. Use the lift handle to raise each baffle to the desired position, retighten both flange nuts, see figures 4-20 & 4-21.

NOTE: DO NOT REMOVE ANY SCREEN PANELS. The flange nuts are best accessed using an extended socket wrench and 9/16" socket through the screen panel openings.

NOTE: Screen removed in figure 4-21 for illustration only.

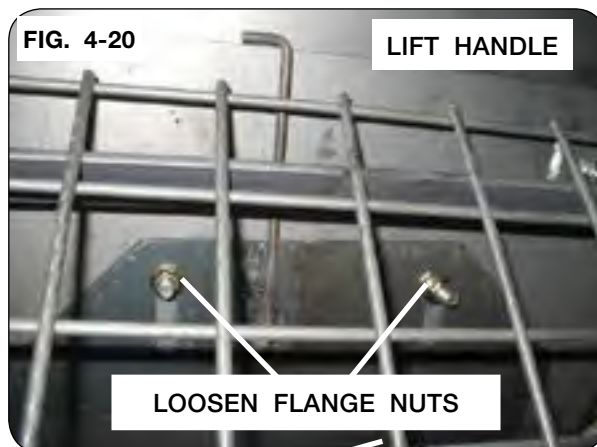

Horizontal Cleanout Door Adjustment

⚠ WARNING

- MOVING OR ROTATING COMPONENTS CAN CAUSE SERIOUS INJURY OR DEATH. ENSURE SERVICE COVERS, CHAIN/BELT COVERS AND CLEANOUT DOORS ARE IN PLACE AND SECURELY FASTENED BEFORE OPERATING UNIT.
- KEEP HANDS CLEAR OF PINCH POINT AREAS.
- TIPPING OR MOVEMENT OF THE MACHINE CAN CAUSE SERIOUS INJURY OR DEATH. BE SURE THE MACHINE IS SECURELY BLOCKED.
- EYE PROTECTION AND OTHER APPROPRIATE PERSONAL PROTECTIVE EQUIPMENT MUST BE WORN WHILE SERVICING THE IMPLEMENT.

1. Park the unit on a firm, level surface. Block the machine to keep it from moving. Set the tractor parking brake, turn off tractor engine, remove ignition key, and disconnect PTO shaft.



2. Loosen all the hardware in the slotted brackets connecting the cleanout door rockshaft to the grain cart tube. (Fig. 4-22)
3. Starting at the front of the cart, using a jack, push the rockshaft up and toward the runner tube. (Fig. 4-22)

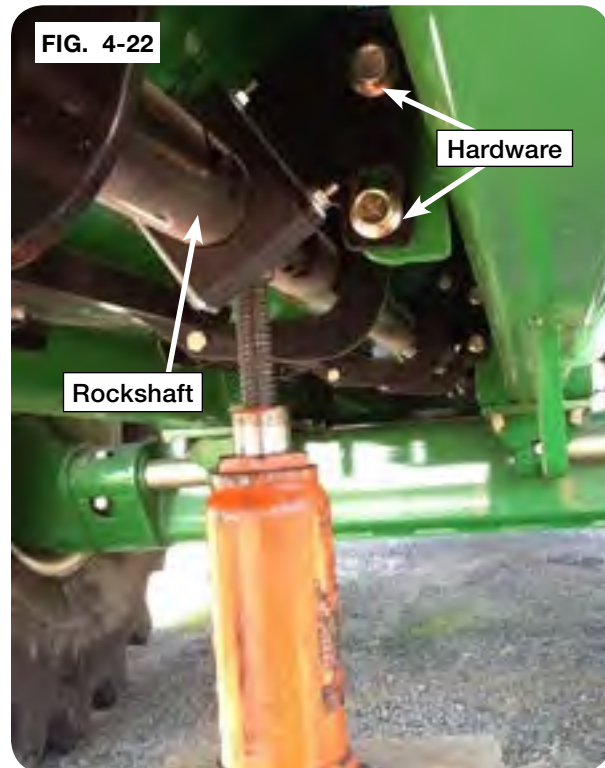

NOTE: Ideal distance between the runner tube and rockshaft is 3 1/4". (FIG. 4-23)

4. When the rockshaft is in position, torque the hardware previously loosened to 28 ft.-lbs.
5. Continue repositioning the rockshaft moving toward the back of the cart.

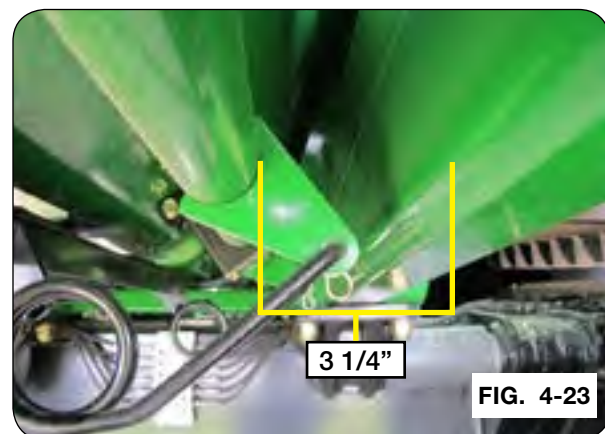

Horizontal Cleanout Door Adjustment

6. Rotate the tensioner handle counter-clockwise to close the doors allowing the plate to fit and seal into the belly pan opening. (Fig. 4-24)

7. If plate insert needs adjustment, loosen the two flat head machine screws holding the plate in position. (Fig. 4-25)

8. Ensure the plate inserts are aligned and fit into the belly pan cut-outs. (Fig. 4-25)

9. Close the doors and ensure all doors seal.

10. Insert lynch pin into rockshaft and return handle to storage location.

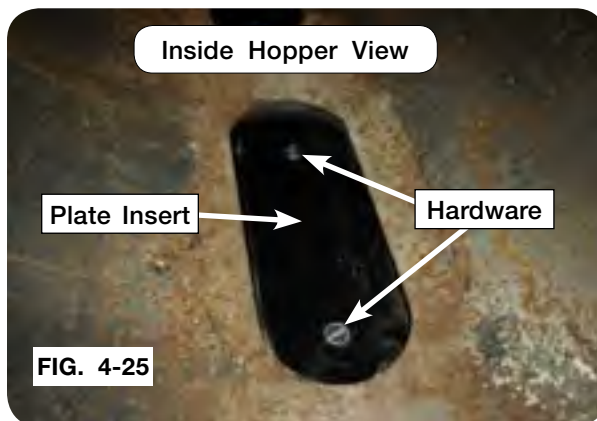

Belt Tightener Adjustment

IMPORTANT

- Do not use belt dressing.
- Keep grease and oil off of belt and pulleys.

NOTE: Pulleys do not need to be removed to remove/replace belt.

Due to prolonged use, belt wear may be evident causing slack. To correct this, follow these steps.

1. Park the unit on a firm, level surface. Block the unit to keep it from moving. Set the vehicle parking brake, shut off the engine, remove the ignition key, and disconnect PTO shaft from tractor.



WARNING

- MOVING OR ROTATING COMPONENTS CAN CAUSE SERIOUS INJURY OR DEATH. ALWAYS DISCONNECT POWER SOURCE BEFORE SERVICING. ENSURE SERVICE COVERS, CHAIN/BELT COVERS AND CLEAN-OUT DOOR(S) ARE IN PLACE AND SECURELY FASTENED BEFORE OPERATING UNIT.

2. Remove PTO assembly from gearbox input shaft.
3. Detension the belt as outlined in OPERATION section. Remove belt tensioner handle.
4. Remove cover and inspect belts for misalignment, loose parts and cracks. Replace if necessary with a matched set. See Fig. 4-28.

FIG. 4-26



Handle down is in engaged position

FIG. 4-27



Handle up is in disengaged position

FIG. 4-28



Belt Tightener Adjustment (continued)

5. Belt tension is adjusted with hex nuts below the spring. All belt tension **MUST** be released from linkage. Loosen outer hex nut and adjust inner nut to establish a 3 1/16" pre-load dimension between the heavy washers. Tighten the outer hex nut against inner nut to lock position. (Fig. 4-29)
6. Check the lower belt pulley to ensure belt is aligned in their grooves and with the belt tensioner handle, engage the roller/idler linkage against the belt and over-center stop. The compressed spring should now be approximately 1 3/4" between the washers and generating a force of approximately 480 lbs. against the belt. (Fig. 4-30)
7. Release and tighten belt multiple times to confirm positions and final adjustments. See Fig. 4-30 and Fig. 4-31.
8. Tighten belt to reinstall the cover guard and the PTO shaft to the gearbox input shaft. Clear work area and test-run drivetrain for 3 minutes at 1000 PTO RPM.

WARNING

- **MOVING OR ROTATING COMPONENTS CAN CAUSE SERIOUS INJURY OR DEATH ENSURE SERVICE COVERS, CHAIN/BELT COVERS AND CLEAN-OUT DOOR ARE IN PLACE AND SECURELY FASTENED BEFORE OPERATING UNIT.**

9. Disengage PTO, turn off towing vehicle and remove the ignition key. Through the cover access door, check the compressed spring length is approximately 1 3/4" between the washers and check each belt for uniform tension. If more adjustment is needed, refer to Steps 5 through 7. If no additional spring adjustment is available, then both belts must be replaced with a new matched set.

NOTE: Always replace belts in matched sets.

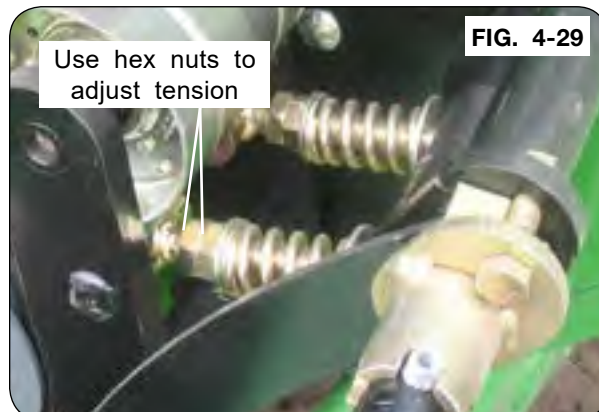

FIG. 4-29



FIG. 4-30



FIG. 4-31

V-Belt Alignment

1. Pulleys must be aligned with the fixed idler. Belts should be centered on idler for longest belt life. (Fig. 4-32)



2. After tightening taper-lock bushing hardware, lay a straight edge across face of the drive and driven belt pulleys to ensure alignment between the grooves on the pulleys. (FIG. 4-33)

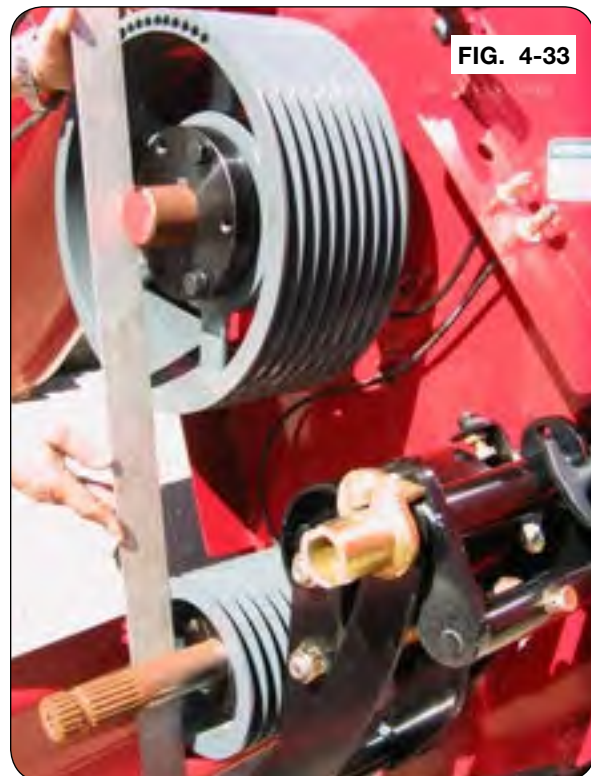

V-Belt Alignment (continued)

Split Tapered Bushings

Check annually for tight engagement to driveshaft. Torque three bolts progressively to values shown in figure 4-34.

For the smaller gearbox bushing (9007376): 3/8"-16UNC hardware. Torque to 75 ft-lbs.

For the larger horizontal auger bushing (9004813): 9/16"-12UNC hardware. Torque to 90 ft.-lbs.

Some gap must remain between flange & hub when bushing is properly tightened.

To remove from shaft, remove capscrews and insert them in tapped holes in bushing flange. Tighten progressively until bushing disengages.

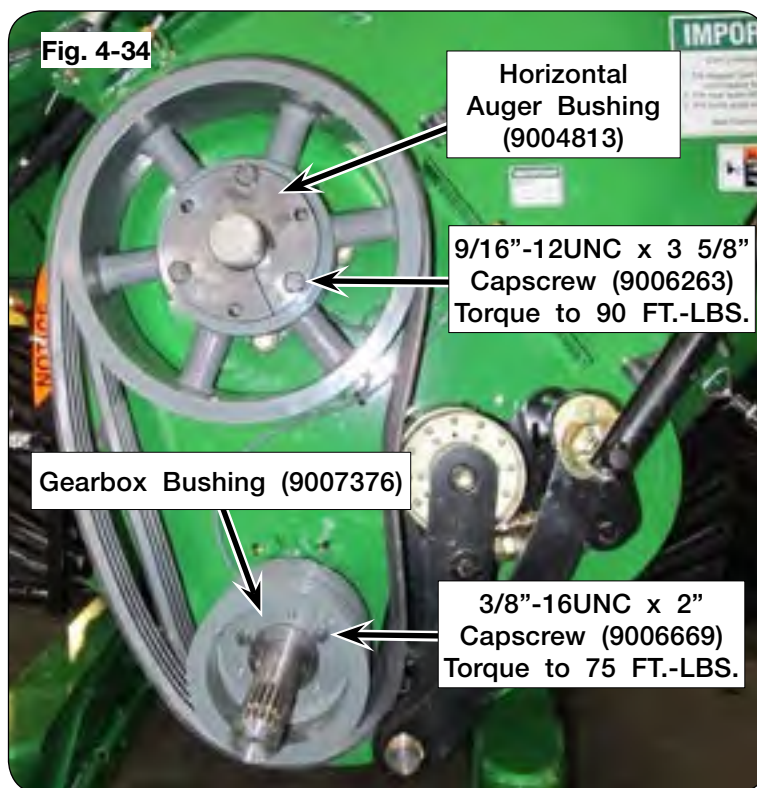

Horizontal Auger Removal and Replacement For SN B40450100 & Higher

WARNING

- TO PREVENT PERSONAL INJURY OR DEATH, ALWAYS ENSURE THAT THERE ARE PEOPLE WHO REMAIN OUTSIDE THE CART TO ASSIST THE PERSON WORKING INSIDE, AND THAT ALL SAFE WORKPLACE PRACTICES ARE FOLLOWED. THERE IS RESTRICTED MOBILITY AND LIMITED EXIT PATHS WHEN WORKING INSIDE THE IMPLEMENT.
- NEVER ENTER CART WITH AUGER OR TRACTOR RUNNING. SERIOUS OR FATAL INJURY CAN OCCUR DUE TO ENTANGLEMENT WITH ROTATING COMPONENTS. ALWAYS STOP ENGINE AND REMOVE KEY BEFORE ENTERING CART.
- EYE PROTECTION AND OTHER APPROPRIATE PERSONAL PROTECTIVE EQUIPMENT MUST BE WORN WHILE SERVICING IMPLEMENT.
- KEEP HANDS CLEAR OF PINCH POINT AREAS.
- FALLING OBJECTS CAN CAUSE SERIOUS INJURY OR DEATH. DO NOT WORK UNDER THE MACHINE AT ANY TIME WHILE BEING HOISTED. BE SURE ALL LIFTING DEVICES AND SUPPORTS ARE RATED FOR THE LOADS BEING HOISTED. THESE ASSEMBLY INSTRUCTIONS WILL REQUIRE SAFE LIFTING DEVICES UP TO 1,000 LBS. SPECIFIC LOAD RATINGS FOR INDIVIDUAL LOADS WILL BE GIVEN AT THE APPROPRIATE TIME IN THE INSTRUCTIONS.

NOTE: Open the flow gates all the way.

1. Park the unit on a firm, level surface. Block the machine to keep it from moving. Set the vehicle parking brake, shut off the engine and remove the ignition key and disconnect the PTO shaft from the tractor.

NOTE: For SN B44630099 & lower, skip to step 4.

2. Remove 4 rear ladder capscrews attached to the cart. (FIG. 4-35)

NOTE: Keep all hardware for re-assembly.

3. Remove rear ladder from the cart. (FIG. 4-35)

NOTE: For SN B44630100 & higher, continue to step 5.

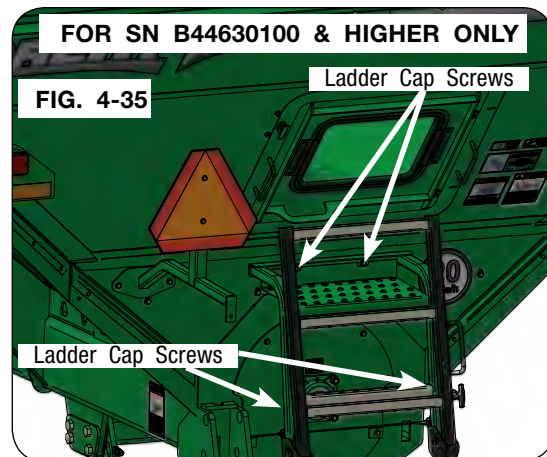

Horizontal Auger Removal and Replacement (continued) For SN B40450100 & Higher

4. For SN B44630099 & lower, remove the SMV bracket located on the rear auger cover. (Fig. 4-36)
5. Remove the capscrews from the auger cover. (Fig. 4-36)
6. Pry the auger from the auger tube. (Fig. 4-37)
7. Using a safe lifting device rated for a minimum 1,000 lbs., pull the rear auger out of the cart. (Fig. 4-38)

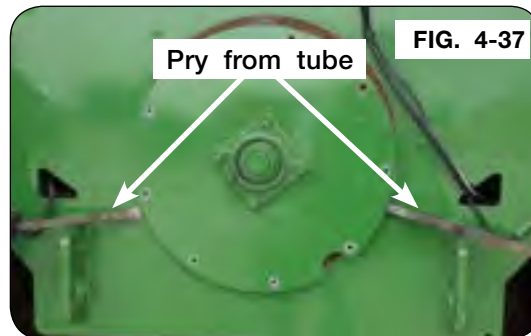
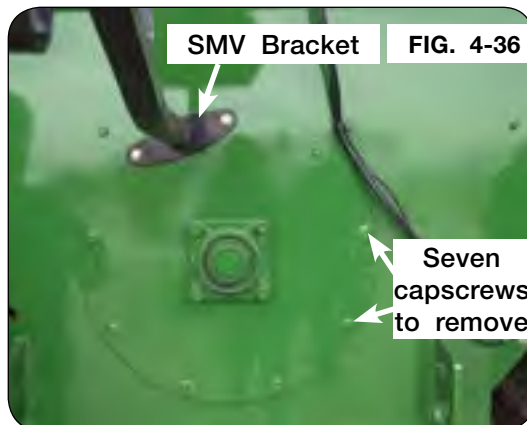

Horizontal Auger Removal and Replacement (continued) For SN B40450100 & Higher

NOTE: If only servicing rear auger, skip to step 23.
For 5-pin driver replacement, continue to step 8.

8. Remove the flange screws in both middle grates inside the cart. Remove the grates. (Fig. 4-39)

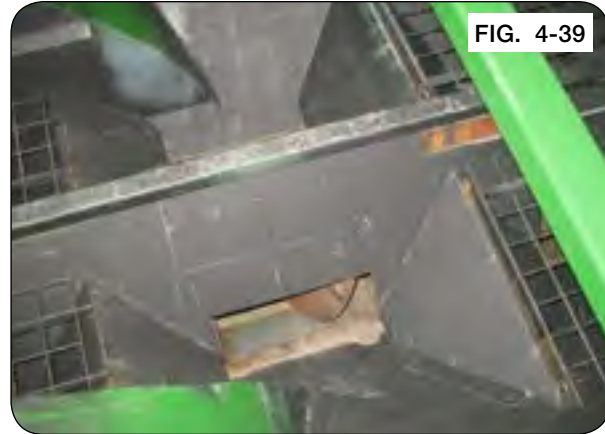

9. Remove locknuts, baffle weldments and cover plates from the middle tent. (Fig. 4-40)

10. Disconnect grease line. (Fig. 4-40)

11. Remove the bearing mount bar bolts on each side of the auger.

12. Remove capscrews and lock washers holding bearing onto the bearing mount bar.

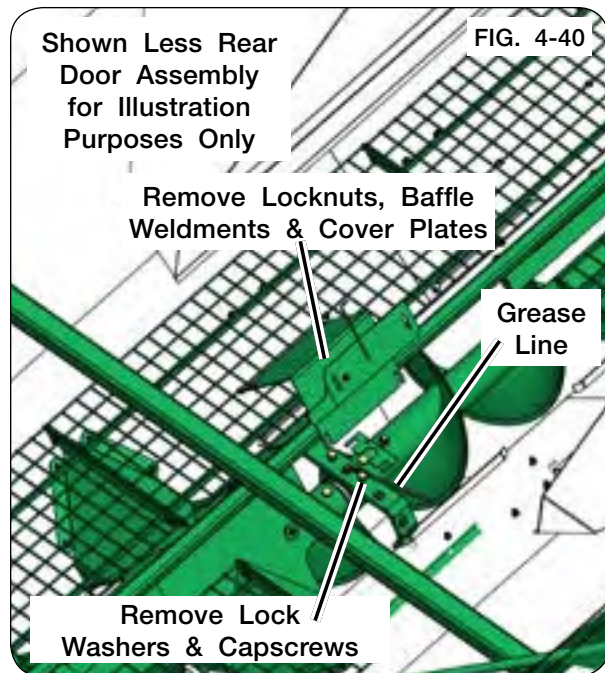

13. Remove bearing mount bar to allow access to work on the bearing and shaft. Remove two center tube connecting capscrews, spacer bushings (283895B) and locknuts from the horizontal auger. (Fig. 4-41)

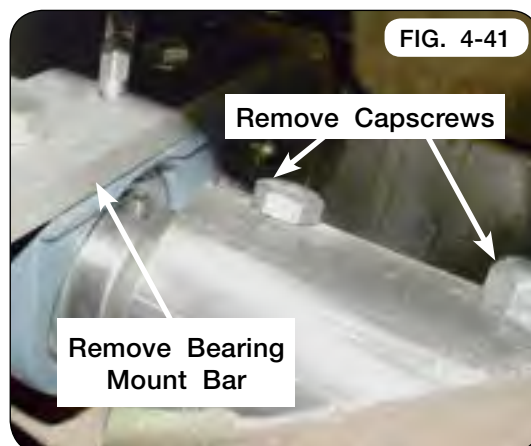

Horizontal Auger Removal and Replacement (continued) For SN B40450100 & Higher

14. Remove the original 5-pin driver, bearing and the bushing insert. (Figs. 4-42 & 4-43)
15. Replace 5-pin driver and bushing insert if needed.

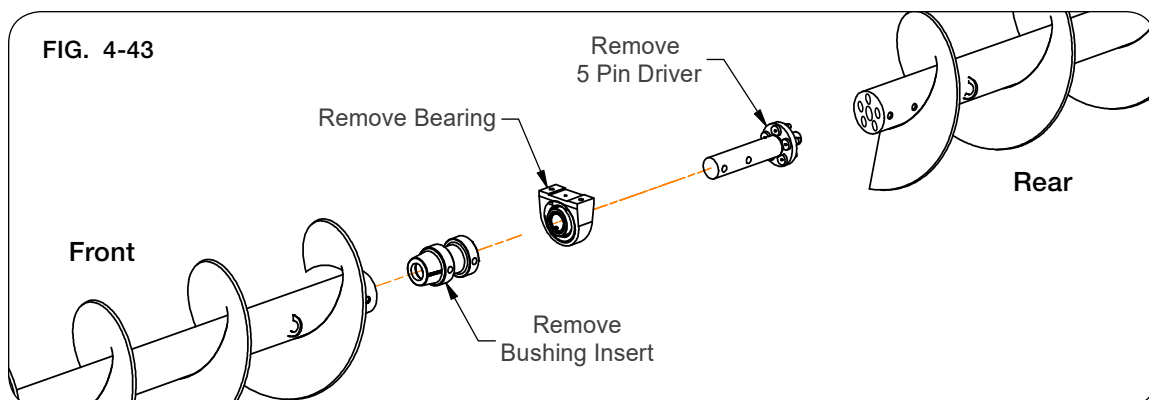

16. Substantially coat bushing insert with anti-seize.
17. Slide bushing insert into front auger and ensure tube holes are aligned. (Figs. 4-43 & 4-44)



NOTE: Make sure the set screws on bearing are towards the front of the cart. (Fig. 4-45)

18. Slide bearing onto 5-pin driver. (Fig. 4-45)
19. Insert 5-pin driver into front auger and ensure tube holes are aligned.
20. Insert capscrews from opposite sides through auger, bushing and driver. Slide spacer bushings over threads and install locknuts. Hand tighten hardware at this time. (Fig. 4-45)

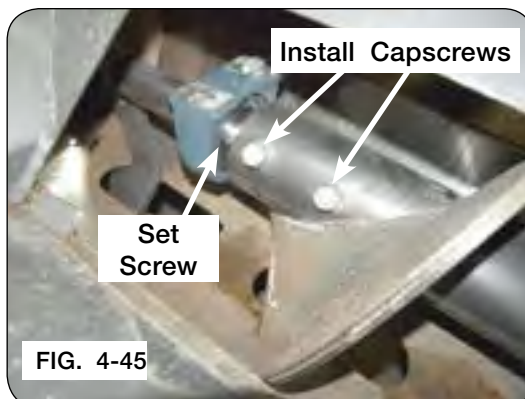

Horizontal Auger Removal and Replacement (continued) For SN B40450100 & Higher

21. Install bearing mount bar. Leave the capscrews and lock washers loose attaching bearing mount bar to the cart. Attach bearing mount bar to the bearing. (Fig. 4-46)

22. Reattach grease line components. (Fig. 4-46)

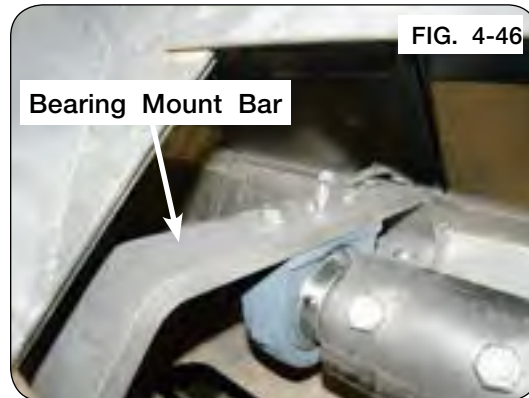

NOTE: Rear auger flighting should lead the front auger flighting.

23. Slide the rear auger forward. Align the pins and holes with the rear auger pipe. (Fig. 4-47)



24. Extend a string tightly from front to rear to check horizontal auger alignment. Measure the string to the auger tube near the hanger bearing. If this dimension is greater than the measurement taken in the front and rear, shims (8GA - 286419B or 12GA - 286424B) are required on top of the center hanger bearing. Ideally the center measurement should be equal to or 1/8" lower than the measurements on the ends of the augers. (Fig. 4-48)



NOTE: Add shims as needed. See "Auger System - Horizontal Auger Height Measurement" in MAINTENANCE section for more details.

25. Torque bearing mount bar capscrews to 130 ft.-lbs. See Fig. 4-46.

26. Torque front auger capscrews to 200 ft.-lbs. (Fig. 4-49)

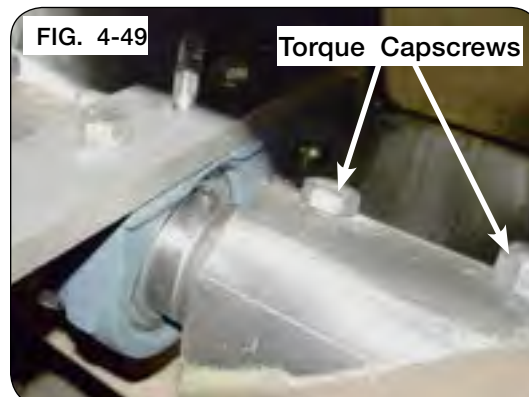

Horizontal Auger Removal and Replacement (continued) For SN B40450100 & Higher

27. Insert hardware for rear auger cover, SMV bracket, and rear ladder, if equipped. (Figs. 4-50 and 4-51)
28. Torque all hardware to specification. See "Torque Chart" in this section. (Figs. 4-50 and 4-51)
29. Reinstall ALL the grates.
30. Ensure all personnel and tools are removed from the cart and reconnect PTO shaft to the tractor.
31. Run the auger starting at a low RPM and increase speed to max RPM to ensure the auger flighting does not make contact with the belly pan or flow doors.

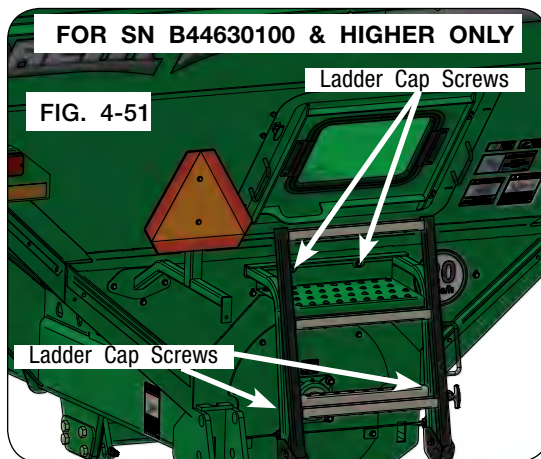
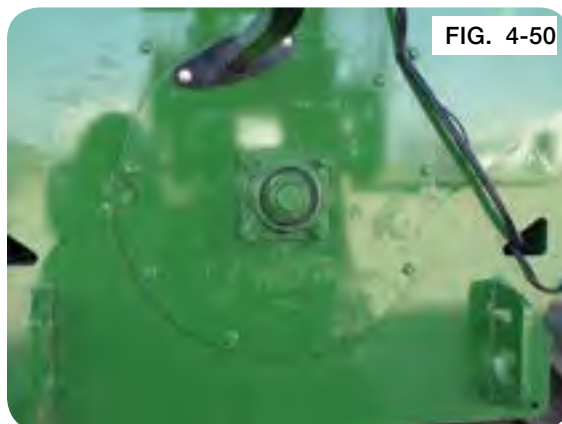

Horizontal Auger Removal and Replacement For SN B40450099 & Lower

⚠ WARNING

- TO PREVENT PERSONAL INJURY OR DEATH, ALWAYS ENSURE THAT THERE ARE PEOPLE WHO REMAIN OUTSIDE THE CART TO ASSIST THE PERSON WORKING INSIDE, AND THAT ALL SAFE WORKPLACE PRACTICES ARE FOLLOWED. THERE IS RESTRICTED MOBILITY AND LIMITED EXIT PATHS WHEN WORKING INSIDE THE IMPLEMENT.
- NEVER ENTER CART WITH AUGER OR TRACTOR RUNNING. SERIOUS OR FATAL INJURY CAN OCCUR DUE TO ENTANGLEMENT WITH ROTATING COMPONENTS. ALWAYS STOP ENGINE AND REMOVE KEY BEFORE ENTERING CART.
- EYE PROTECTION AND OTHER APPROPRIATE PERSONAL PROTECTIVE EQUIPMENT MUST BE WORN WHILE SERVICING IMPLEMENT.
- KEEP HANDS CLEAR OF PINCH POINT AREAS.
- FALLING OBJECTS CAN CAUSE SERIOUS INJURY OR DEATH. DO NOT WORK UNDER THE MACHINE AT ANY TIME WHILE BEING HOISTED. BE SURE ALL LIFTING DEVICES AND SUPPORTS ARE RATED FOR THE LOADS BEING HOISTED. THESE ASSEMBLY INSTRUCTIONS WILL REQUIRE SAFE LIFTING DEVICES UP TO 1,000 LBS. SPECIFIC LOAD RATINGS FOR INDIVIDUAL LOADS WILL BE GIVEN AT THE APPROPRIATE TIME IN THE INSTRUCTIONS.

NOTE: Open the flow gates all the way.

1. Park the unit on a firm, level surface. Block the wheels to keep the machine from moving. Set the vehicle parking brake, shut off the engine and remove the ignition key and disconnect the PTO shaft from the tractor.
2. Remove the flange screws in both middle grates inside the cart. Remove the grates. (Fig. 4-52)

NOTE: Retain all hardware for reassembly.

3. Remove locknuts, baffle weldments and cover plates from the middle tent. (Fig. 4-53)
4. Remove grease line. (Fig. 4-53)

NOTE: For 1600 bushel carts and lower, the locknuts on bearing mount bar are located on the outside of the cart.

5. Remove the bearing mount bar bolts on each side of the auger.
6. Remove capscrews and lock washers holding bearing onto the bearing mount bar.



FIG. 4-52

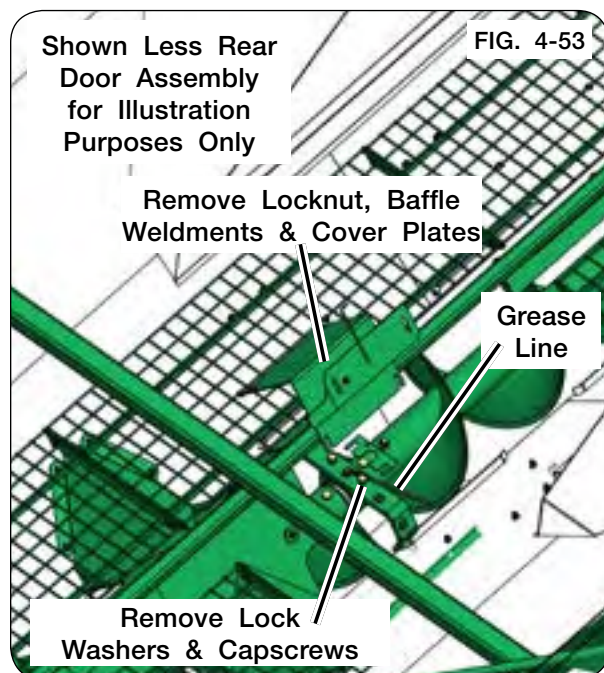
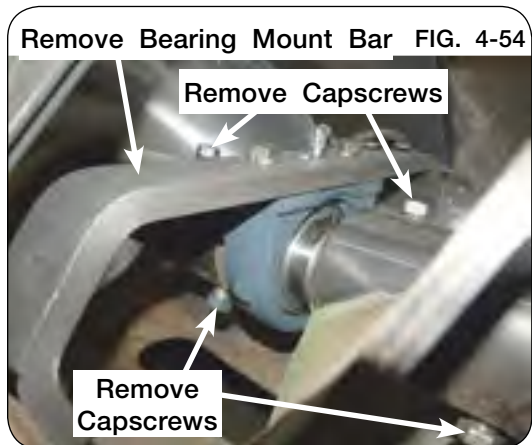

FIG. 4-53

Horizontal Auger Removal and Replacement (continued) For SN B40450099 & Lower

7. Remove bearing mount bar to allow access to work on the bearing and shaft. Remove four center tube connecting capscrews, spacer bushings (283895B) and locknuts in the horizontal auger. (Figure 4-54)



8. Remove the SMV bracket located on the rear auger cover. (Figure 4-55)

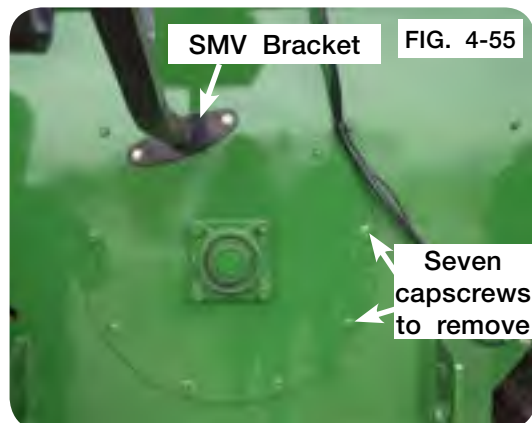

9. Remove the capscrews from the auger cover. (Figure 4-55)

10. Pry the auger from the auger tube. (Figure 4-56)

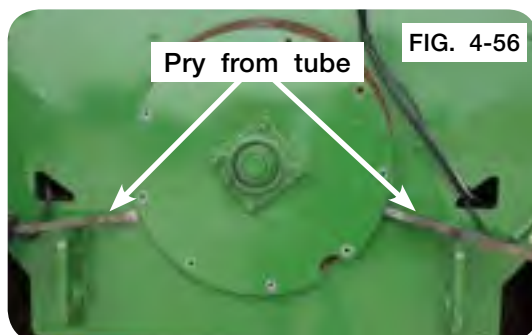

11. Using a safe lifting device rated for a minimum 1,000 lbs., pull the rear auger out of the cart. (Figure 4-57)



Horizontal Auger Removal and Replacement (continued) For SN B40450099 & Lower

12. Remove the connecting shaft, bearing and the two bushing inserts. (Figs. 4-58 & 4-59)

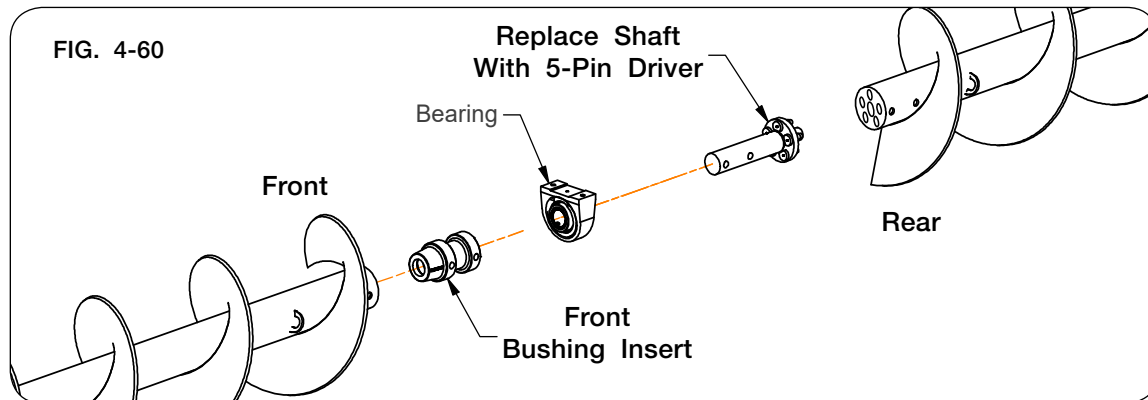
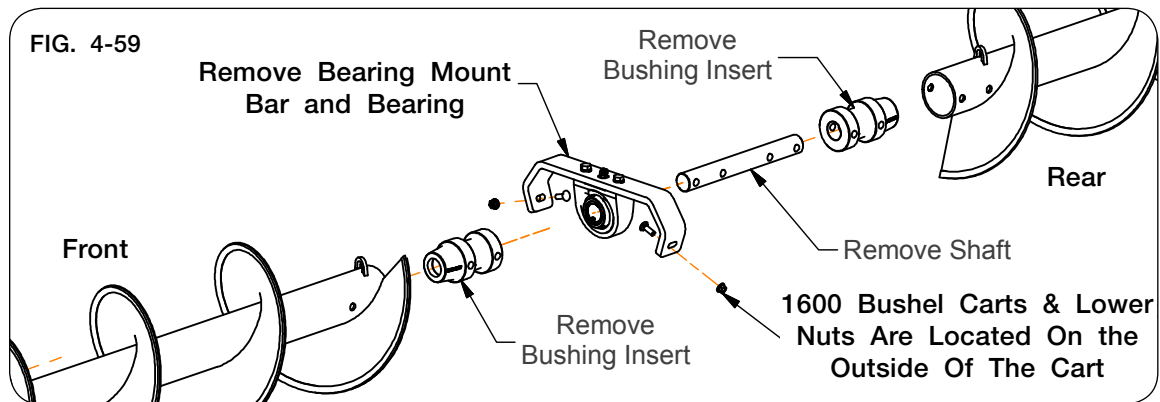

13. Replace connecting shaft with 5-pin driver (293957). (Fig. 4-60)
14. Replace front auger bushing insert with new insert (286282). (Fig. 4-60)
15. Discard rear auger bushing insert. (Fig. 4-59)
16. Substantially coat front bushing insert with anti-seize.
17. Slide bushing insert into front auger and ensure tube holes are aligned. (Figs. 4-60 & 4-61)



Horizontal Auger Removal and Replacement (continued) For SN B40450099 & Lower

NOTE: Make sure the set screws on bearing are towards the front of the cart. (Fig. 4-62)

18. Slide bearing onto 5-pin driver. (Fig. 4-62)
19. Insert 5-pin driver into front auger and ensure tube holes are aligned.
20. Insert capscrews from opposite sides through auger, bushing and driver. Slide spacer bushings over threads and install locknuts. Hand tighten hardware at this time. (Fig. 4-62)
21. Install bearing mount bar. Leave the capscrews and lock washers loose attaching bearing mount bar to the cart. Attach bearing mount bar to the bearing. (Fig. 4-63)
22. Reattach grease line components. (Fig. 4-63)

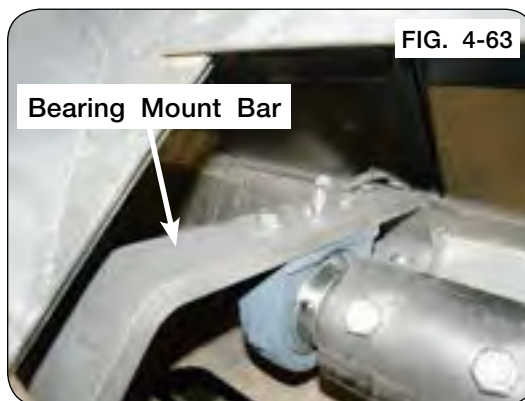
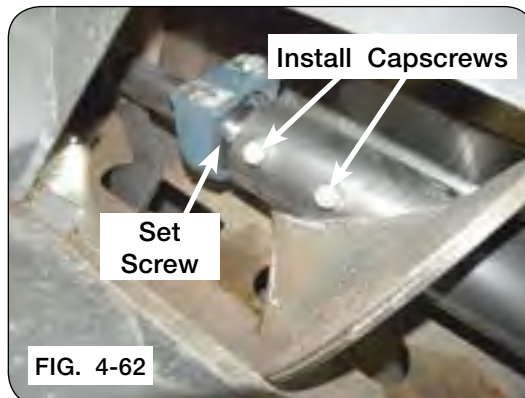

NOTE: Rear auger flighting should lead the front auger flighting.

23. Slide the rear auger forward. Align the pins and holes with the rear auger pipe. (Fig. 4-64)



24. Extend a string tightly from front to rear to check horizontal auger alignment. Measure the string to the auger tube near the hanger bearing. If this dimension is greater than the measurement taken in the front and rear, shims (8GA - 286419B or 12GA - 286424B) are required on top of the center hanger bearing. Ideally the center measurement should be equal to or 1/8" lower than the measurements on the ends of the augers. (Fig. 4-65)



NOTE: Add shims as needed. See "Auger System - Horizontal Auger Height Measurement" in MAINTENANCE section for more details.

Horizontal Auger Removal and Replacement (continued) For SN B40450099 & Lower

25. Torque bearing mount bar capscrews to 130 ft.-lbs. See Fig. 4-63 on previous page.
26. Torque front auger capscrews to 200 ft.-lbs. (Fig. 4-66)
27. Reattach the rear auger cover and SMV bracket back onto the cart. (Fig. 4-67)
28. Reinstall ALL cover plates, baffle weldments, locknuts, and grates.
29. Ensure all personnel and tools are removed from the cart and reconnect PTO shaft to the tractor.
30. Run the auger starting at a low RPM and increase speed to max RPM to ensure the auger flighting does not make contact with the belly pan or flow doors.

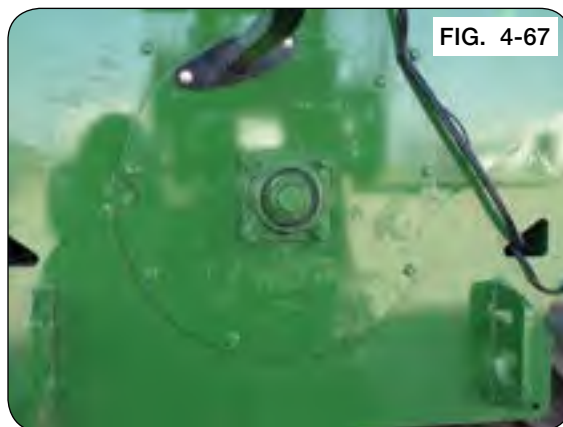
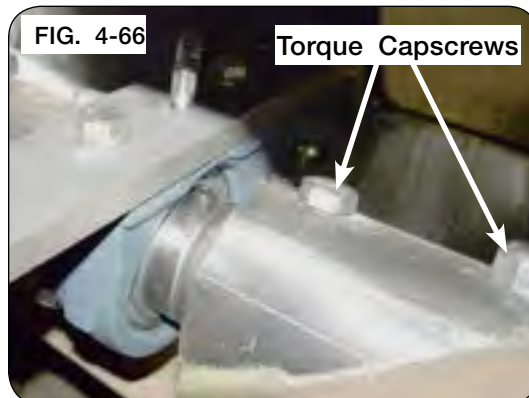

Driveline Removal

DANGER

- ENTANGLEMENT WITH THE DRIVELINE WILL CAUSE SERIOUS INJURY OR DEATH. KEEP ALL GUARDS AND SHIELDS IN GOOD CONDITION AND PROPERLY INSTALLED AT ALL TIMES. AVOID PERSONAL ATTIRE SUCH AS LOOSE FITTING CLOTHING, SHOE STRINGS, DRAWSTRINGS, PANTS CUFFS, LONG HAIR, ETC. THAT CAN BECOME EN-TANGLED IN A ROTATING DRIVELINE.

WARNING

- MOVING OR ROTATING COMPONENTS CAN CAUSE SERIOUS INJURY OR DEATH. ALWAYS DISCONNECT POWER SOURCE BEFORE SERVICING. ENSURE SERVICE COVERS, CHAIN/BELT COVERS AND CLEAN-OUT DOOR ARE IN PLACE AND SECURELY FASTENED BEFORE OPERATING UNIT.

Gearbox shaft guard has access doors for installing and removing of driveline.

1. Remove clamping cone/retaining bolt.
2. Use a hammer and punch, if needed, to moderately hit the end of clamping cone/retaining bolt, as shown. (FIG. 4-68)
3. Once clamping cone/retaining bolt is removed, slide torque limiter off gearbox splined input shaft.

Fig. 4-68

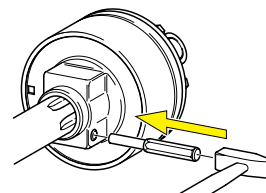

Gearbox

When checking the oil level of the gearbox, the vertical auger should be pivoted all the way down.

For adequate lubrication, the oil should be visible in the sight glass. Fill with oil to the sight glass only. (Fig. 4-69)

For Maximum gearbox life:

Check oil level every 2 weeks.

Replace oil every season with approximately 85 oz. 80W90 EP lubricant.

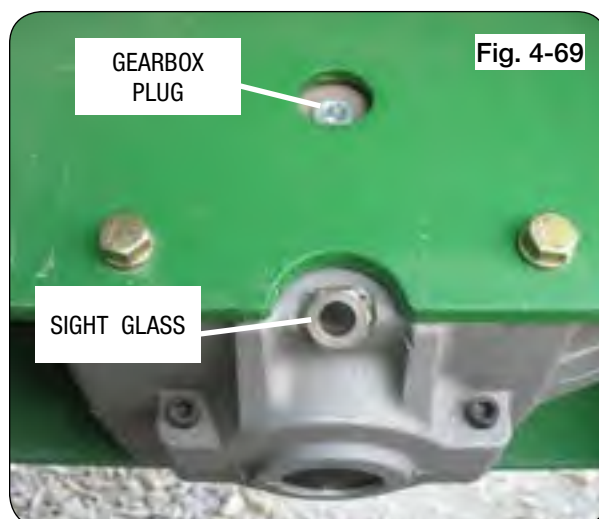

Verify Telescoping PTO Shaft Length

⚠ WARNING

- PROPER EXTENDED AND COLLAPSED LENGTHS OF THE TELESCOPING PTO SHAFT MUST BE VERIFIED BEFORE FIRST OPERATION WITH EACH AND EVERY TRACTOR. IF THE EXTENDED LENGTH OF THE PTO SHAFT IS NOT SUFFICIENT, IT MAY BECOME UNCOUPLED IN OPERATION AND CAUSE SERIOUS INJURY OR DEATH FROM CONTACT WITH UNCONTROLLED FLAILING OF PTO SHAFT ASSEMBLY COMPONENTS.

IMPORTANT

- Check the length of the telescoping members to ensure the driveline will not bottom out or separate when turning and/or going over rough terrain.

Consult your OEM dealer for recommended drawbar and PTO set up.

An excessive collapsed length can result in damage to the PTO driveline and attached components. This is most likely to occur during extreme turning angles and/or travel over rough terrain. Conditions are amplified on tractors with tracks operating in uneven terrain, particularly rice levies. Damaged driveline components can result in unsafe operation and severely reduced driveline component life.

Check the length of the telescoping members to ensure the driveline will not bottom out or separate when turning and/or going over rough terrain.

NOTE: Do not exceed 10 degrees beyond a straight pull line while operating the PTO. To verify proper extended and collapsed lengths, use the following procedure:

1. Fully collapse PTO shaft and measure length "L" (Fig. 4-70).

Enter here: _____ (1)

(Verify that outer tube does not bottom out on surrounding plastic shield components).

2. Pull apart PTO telescoping shaft ends and measure lengths "T" & "C" (Fig. 4-71)

Add "T" + "C" measurements together

Enter total here: _____ (2)

3. Calculate maximum recommended extended length:

- a. Subtract line 1 from line 2

Enter here: _____ (a)

- b. Divide line (a) by 2

Enter here: _____ (b)

- c. Add line (b) to line 1.

Enter here: _____ (c)

- d. Subtract 3 inches from line (c)

Enter here: _____ (d)

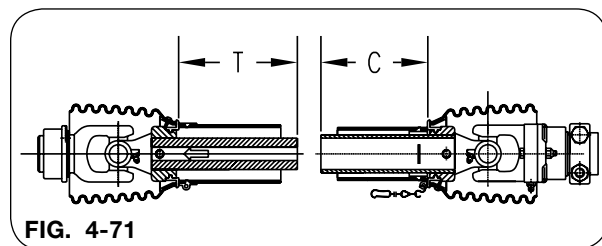
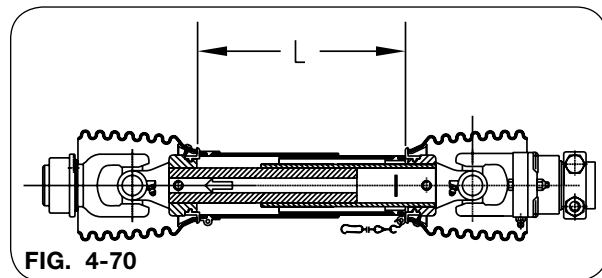

This is the maximum recommended extended length.

Verify Telescoping PTO Shaft Length (continued)

4. Hitch tractor drawbar to cart, ensuring that tractor and cart are on level ground and coupled as straight as practical.
5. Connect PTO shaft to tractor, and measure length “L” from same points as used in step 1. Ensure that this measurement does not exceed the maximum recommended extended length calculated in step 3 above. If necessary, choose a shorter drawbar position, or obtain a longer PTO shaft assembly before operating cart.
6. Position the tractor to obtain the tightest turning angle, relative to the cart (Fig. 4-72).
7. Measure the length “L” from the same points as used in step 1. **This distance must be at least 1.5 inches greater than the distance measured in step 1.** If necessary, adjust the length of the PTO shaft by cutting the inner and outer plastic guard tubes and inner and outer sliding profiles by the same length. Round off all sharp edges and remove burrs before greasing and reassembling shaft halves. (Fig. 4-73)

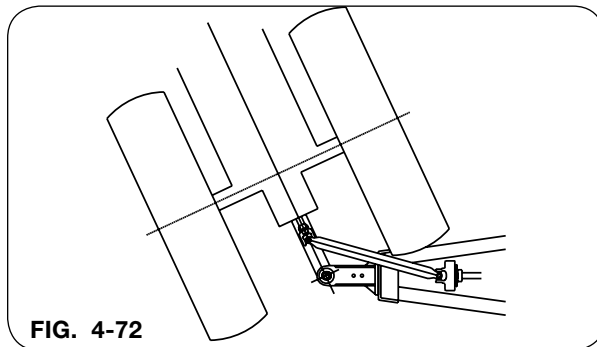

FIG. 4-72

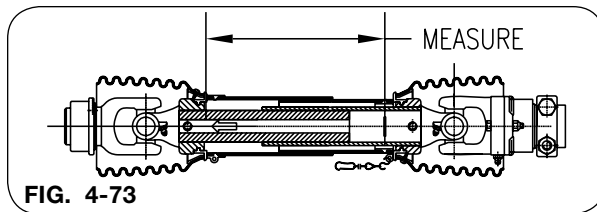

FIG. 4-73

PTO Shaft Length Adjustment

WARNING

- **CHECK THE LENGTH OF THE TELESCOPING MEMBERS TO ENSURE THE DRIVELINE WILL NOT BOTTOM OUT OR SEPARATE WHEN TURNING AND/OR GOING OVER ROUGH TERRAIN.**

NOTE: Maximum operating length LB. (Refer to “Verify Telescoping PTO Shaft Length” in this section for LB length.)

1. To adjust length, hold the half-shafts next to each other in the shortest working position and mark them.
2. Shorten inner and outer guard tubes equally.
3. Shorten inner and outer sliding profiles by the same length as the guard tubes.
4. Round off all sharp edges and remove burrs. Grease sliding profiles.

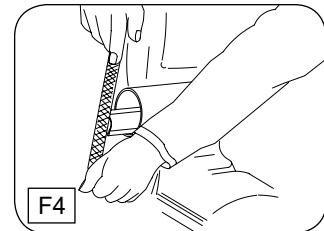
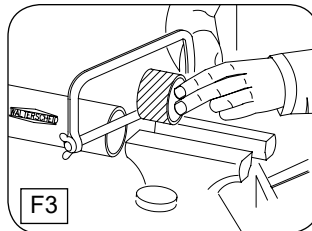
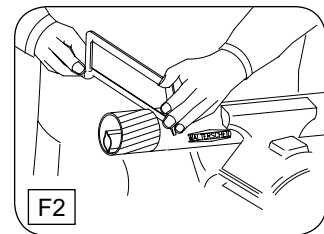
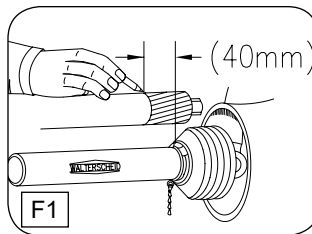

PTO Shaft and Clutch - Benzi PTO

To Dismantle Guard (Figs. J1 - J3)

1. Pull the guard tube backwards and, using a screwdriver, disengage the three bearing ring tabs by pushing them inward. (FIG. J1)



2. Remove half-guard. (FIG. J2)



3. Open the bearing ring and remove from the yoke groove. (FIG. J3)



PTO Shaft and Clutch - Benzi PTO (continued)

To Assemble Guard (Figs. K1 - K3)

1. Clean and grease the bearing ring, yoke groove and inner profile tube. (FIG. K1)



2. Fit bearing ring in groove with three bearing ring tabs positioned as shown. (FIG. K2)
3. Slip on half-guard by aligning the holes on the cone with three bearing ring tabs and the cone inner key with the cut of the bearing ring. (FIG. K2)



4. Push half-guard and yoke together causing the half-guard to engage. (FIG. K3)

NOTE: Ensure the three bearing ring tabs are positioned inside the grooves.

5. Confirm half-guard engagement by pulling backwards on the half-guard. (FIG. K3)



PTO Shaft and Clutch - GKN Walterscheid PTO

To Dismantle Guard (Figs. J1 - J4)

1. Remove locking screw.
2. Align bearing tabs with cone pockets.
3. Remove half-guard.
4. Remove bearing ring.

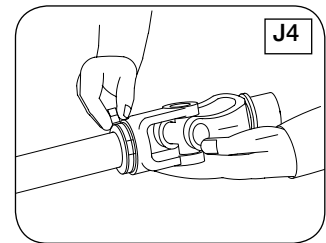
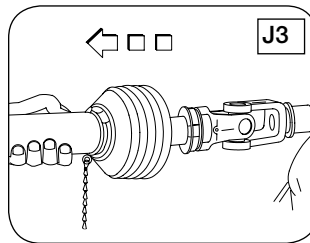
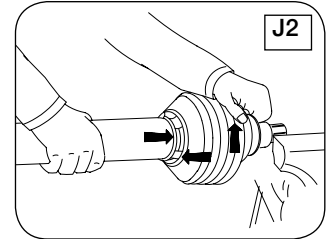
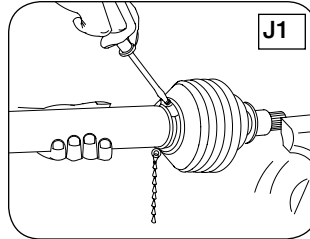

PTO Shaft and Clutch - GKN Walterscheid PTO (continued)

To Assemble Guard (Figs. K1 - K5)

1. Grease yoke groove and inner profile tube.
2. Fit bearing ring in groove with recesses facing profile tube.
3. Slip on half-guard.
4. Turn cone until it engages correctly.
5. Install locking screw.

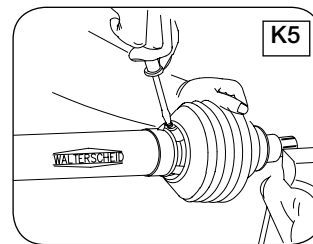
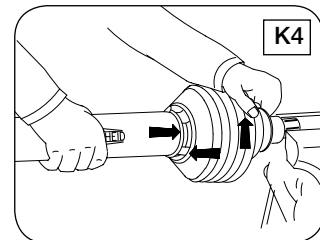
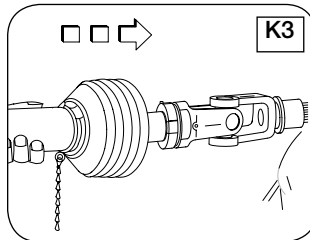
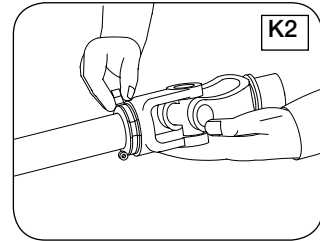
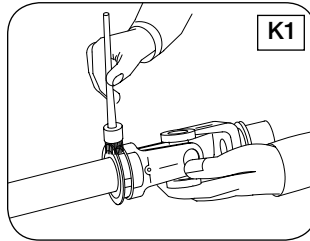

To Assemble Cone (Figs. L1 - L3)

1. Dismantle guard (Figs. J1 - J3). Remove old cone (e.g. cut open with knife). Take off chain. Place neck of new cone in hot water (approx 80° C / 180° F) and pull onto bearing housing (Fig. L1).
2. Turn guard cone into assembly position (Fig. L2). Further assembly instructions for guard (Figs. K1 - K5).
3. Reconnect chain if required (Fig. L3).

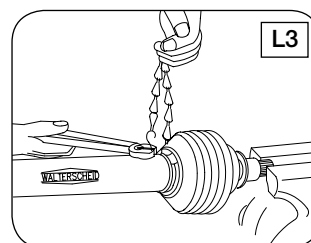
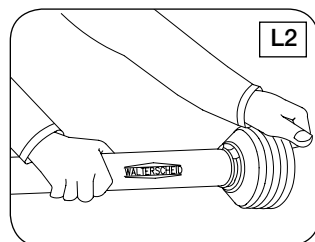
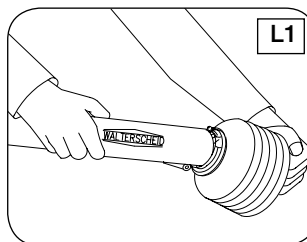

Wheel, Hub and Spindle Disassembly and Assembly

WARNING

- **TIPPING OR MOVEMENT OF THE MACHINE CAN CAUSE SERIOUS INJURY OR DEATH. BE SURE MACHINE IS SECURELY BLOCKED.**
- **FALLING OBJECTS CAN CAUSE SERIOUS INJURY OR DEATH. DO NOT WORK UNDER THE MACHINE AT ANY TIME WHILE BEING HOISTED. BE SURE ALL LIFTING DEVICES AND SUPPORTS ARE RATED FOR THE LOADS BEING HOISTED. THESE ASSEMBLY INSTRUCTIONS WILL REQUIRE SAFE LIFTING DEVICES UP TO 30,000 LBS. SPECIFIC LOAD RATINGS FOR INDIVIDUAL LOADS WILL BE GIVEN AT THE APPROPRIATE TIME IN THE INSTRUCTIONS.**

CAUTION

- **IMPROPERLY TORQUED WHEEL NUTS/BOLTS CAN CAUSE A LOSS OF IMPLEMENT CONTROL AND MACHINE DAMAGE. TORQUE WHEEL NUTS/BOLTS TO VALUES IN TABLE. CHECK TORQUE BEFORE USE, AFTER ONE HOUR OF UNLOADED USE OR AFTER FIRST LOAD, AND EACH LOAD UNTIL WHEEL NUTS/BOLTS MAINTAIN TORQUE VALUE. CHECK TORQUE EVERY 10 HOURS OF USE THERE-AFTER. AFTER EACH WHEEL REMOVAL START TORQUE PROCESS FROM BEGINNING. WARRANTY DOES NOT COVER FAILURES CAUSED BY IMPROPERLY TORQUED WHEEL NUTS/BOLTS.**

IMPORTANT

- *Remove only one wheel and tire from a side at any given time in the following procedure.*

1. Hitch cart to tractor. Park the empty cart on a firm, level surface. Set the tractor's parking brake, shut off engine and remove key.



2. With cart empty, use safe lifting and load holding devices rated at 30,000 lbs. to support the weight of your grain cart. Place the safe lifting device under the axle closest to the tire.
3. Use a 3,000 lbs. safe lifting device to support the wheel and tire during removal.
4. If only changing wheel and tire, skip to Step 8; otherwise continue with Step 4.

Remove the hardware retaining the hubcap. Next, remove the hubcap, gasket, cotter pin, castle nut and spindle washer. Remove hub with bearings from old spindle using a 200 lb. safe lifting device.

5. Inspect the spindle and replace if necessary. If spindle does not need to be replaced, skip to Step 6; otherwise continue with Step 5.

Remove the bolt and lock nut that retain the spindle to the axle. Using a safe lifting device rated for 200 lbs., replace the old spindle with a new spindle. Coat axle contact length of spindle shaft (scale or non-scale) with anti-seize lubricant prior to installation. If installing scale spindle, install with 'top' decal facing upwards. Reuse bolt and lock nut to retain spindle to axle. Tighten as outlined in MAINTENANCE section.

Wheel, Hub and Spindle Disassembly and Assembly (continued)

6. Remove seal and inspect bearings, spindle washer, castle nut and cotter pin. Replace if necessary. Pack both bearings with approved grease and reinstall inner bearing. Install new seal in hub with garter spring facing the outside of hub by tapping on flat plate that completely covers seal while driving it square to hub. (FIG. 4-74) Install until flush with back face of hub. Using a safe lifting device rated for 200 lbs., install hub assembly onto spindle. Install outer bearing, spindle washer and castle nut.

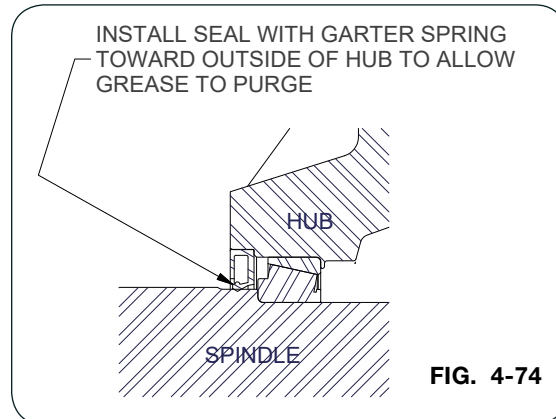

7. Slowly tighten castle nut while spinning the hub until drag causes the hub to stop freely spinning. Do not use an impact! Turn castle nut counterclockwise until the hole in the spindle aligns with the next notch in castle nut. Hub should spin smoothly with little drag and no end play. If play exists, tighten to next notch of castle nut. If drag exists, then back castle nut to next notch of castle nut. Spin and check again. Install cotter pin. Clean face for hub cap gasket and install gasket, grease-filled hub cap and retain hubcap with hardware removed. Tighten hubcap hardware in alternating pattern.
8. Attach the wheel(s) and tire(s) to the hub using the same rated safe lifting device for removal. Tighten wheel nuts to appropriate requirements and recheck as outlined in the Wheel and Tire section of this manual.
9. Raise cart, remove safe load holding devices and lower tire to the ground.

Wheels and Tires

Wheel Nut Torque Requirements

CAUTION

- IMPROPERLY TORQUED WHEEL NUTS/BOLTS CAN CAUSE A LOSS OF IMPLEMENT CONTROL AND MACHINE DAMAGE. TORQUE WHEEL NUTS/BOLTS TO VALUES IN TABLE. CHECK TORQUE BEFORE USE, AFTER ONE HOUR OF UNLOADED USE OR AFTER FIRST LOAD, AND EACH LOAD UNTIL WHEEL NUTS/BOLTS MAINTAIN TORQUE VALUE. CHECK TORQUE EVERY 10 HOURS OF USE THERE-AFTER. AFTER EACH WHEEL REMOVAL START TORQUE PROCESS FROM BEGINNING. WARRANTY DOES NOT COVER FAILURES CAUSED BY IMPROPERLY TORQUED WHEEL NUTS/BOLTS.

Failure to check torque before first load may damage wheel nut/bolt seats. Once seats are damaged, it will become impossible to keep nuts/bolts tight. Tighten nuts/bolts to applicable torque value shown in table. Start all nuts/bolts by hand to prevent cross threading. Torque nuts/bolts in the recommended sequence as shown in Diagram 1.

NOTE: Do not use anti-seize on wheel hardware.

WHEEL HARDWARE	
SIZE	FOOT-POUNDS
7/8-14 (UNF)	440 ft.-lbs.
M22x1.5	475 ft.-lbs.

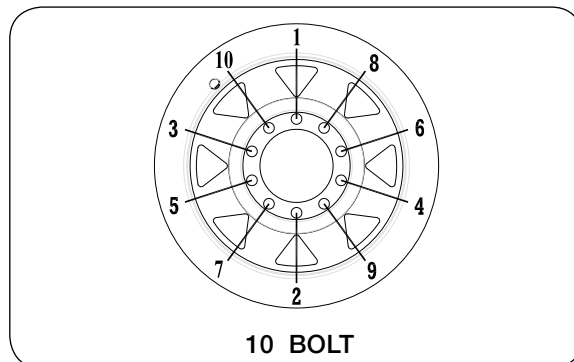

10 BOLT

DIAGRAM 1

Wheels and Tires (continued)

Tire Pressure

The following is to be used as a general guide for tire inflation and figures can vary depending on specific brand of tire used. **It is important that tires are inspected after unit is loaded.** Start with minimum pressure recommended by tire manufacturer. The tire should stand up with no side-wall buckling or distress as tire rolls. Record the pressure needed to support the full load and maintain this pressure to achieve proper tire life. **Do not exceed maximum recommended tire pressure.** Each tire must be inflated to max PSI to seat the beads, deflated to 5-10 PSI, then reinflated to recommended minimum pressure.

Tire Pressure for Grain Carts

Tire Make	Tire Size	Load Index / Ply Rating	Max. PSI
Firestone	23.1x26 R-3	12	32
	23.1x26 R-1	12	32
	28Lx26 R-3	12	26
	24.5x32 R-3	12	32
	24.5x32 R-1	12	32
	30.5x32 R-1	14	28
	30.5x32 R-3	14	28
	30.5x32 R-3	16	34
	30.5x32 R-1	16	26
	35.5x32 R-3	20	36
	76x50.00x32 HF-3	16	40
	76x50.00x32 HF-3	20	50
	800/65R32 R-1W	172D	41
	800/60R32 R-3	181B	46
	900/65R32 R-3	191B	46
	900/60R32 R-1	176A8	44
	1250/50R32F IF/CFO R-1WNP	201D	46
	1250/50R32F IF/CFO R-1W	188B	30
	520/85R38 R-1	155A8	29
	520/85R38 R-1	173A8	64
	480/80R42 R-1	151A8	36
	520/85R42 R-1	157A8	29
	520/85R42 R-1	165A8	51
	520/85R42 IF/CFO R-1	169A8/B	35
	IF520/85R42 R-1W	169B	35
	VF520/85R42 R-1W	177B	35
	420/80R46 R-1	151A8	44
	480/80R46 R-1	158A8	44
380/90R46 R-1	152B	51	

Wheels and Tires (continued)

Tire Pressure (continued)

Tire Pressure for Grain Carts			
Tire Make	Tire Size	Load Index / Ply Rating	Max. PSI
Titan/Goodyear	23.1x26 R-3	10	26
	23.1x26 R-1	10	26
	24.5R32 R-1	169A8/B (5-Star)	48
	24.5x32 R-3	12	32
	24.5x32 R-1	12	32
	30.5x32 R-3	16	26
	30.5x32 R-3	14	22
	30.5x32 R-1	14	22
	480/80x42 R-1	166A8	23
	1100/45R46 F-1W	195D	35
Mitas	650/75R32 R-1W	172A8	58
	650/75R32 R-1	176A8	41
	800/65R32 R-1W	172A8	46
	900/60x32 R-1W	176A8	41
	900/70R32 R-1W	188A8	53
	1050/50x32 R-1W	178A8	41
	1250/50R32 R-1W	188A8	41
	900/60x38 R-1W	181A8	44
	520/85x42 R-1W	162A8	44
	650/65x42 R-1W	168A8	44
Alliance	30.5B32	18-Ply	36
	35.5LR32	193A8	44
	900/60R32 R-1W	192D	46
	1050/50R32 R-1W	185A8	52
	1250/50R32 R-1W	201B	46
Trelleborg	VF1050/50R32 R-1	198D	52
	900/50R32 R-1W	181A8	55
	900/60x32	176LI	44
	850/55R42 R-1W	161A8	32

Wheels and Tires (continued)

Tire Warranty

For questions regarding new tire warranty, please contact your local original equipment tire dealer. Used tires carry no warranty. Following are phone numbers and Websites for your convenience:

Firestone	www.firestoneag.com Phone 800-847-3364
Titan or Goodyear	www.titan-intl.com Phone 800-USA-BEAR Fax 515-265-9301
Trelleborg	www.trelleborg.com Phone 866-633-8473
Continental/Mitas	www.mitas-tires.com Phone 704-542-3422 Fax 704-542-3474
Alliance	www.atgtire.com Phone 781-325-3801

Bleeding Procedure For Braking System

⚠ WARNING

- RELIEVE THE HYDRAULIC SYSTEM OF ALL PRESSURE BEFORE ADJUSTING OR SERVICING. SEE THE HYDRAULIC POWER UNIT OPERATOR'S MANUAL FOR PROPER PROCEDURES.
- HIGH-PRESSURE FLUIDS CAN PENETRATE THE SKIN AND CAUSE SERIOUS INJURY OR DEATH. LEAKS OF HIGH-PRESSURE FLUIDS MAY NOT BE VISIBLE. USE CARDBOARD OR WOOD TO DETECT LEAKS IN THE HYDRAULIC SYSTEM. SEEK MEDICAL TREATMENT IMMEDIATELY IF INJURED BY HIGH-PRESSURE FLUIDS.
- EYE PROTECTION AND OTHER APPROPRIATE PERSONAL PROTECTIVE EQUIPMENT MUST BE WORN WHILE SERVICING IMPLEMENT.
- PLACE TRACTOR IN PARK. TRACTOR MUST IN PARK DURING ENTIRE PROCEDURE.

NOTE: System is intended for tractors with hydraulic trailer brakes. If your tractor does not have hydraulic trailer brakes, contact your dealer for support.

NOTE: This procedure is a two-person process. With responsible operator behind controls, one person operates the brake pedal while the second person loosens the bleeder screw on the brake caliper.

1. Block tires to prevent movement. Set the tractor parking brake, but leave tractor engine on throughout the procedure. Brakes can be attached to either the front or rear set of wheels. Attach hydraulic brake coupler on the cart to the implement brake port at the rear of the tractor.
2. Apply and hold pressure to brake pedal.
3. Attach a clear 1/4" hose to fitting. Put hose in an approved container and submerge the end in brake fluid. Loosen the bleeder screw, at the top of the brake caliper, on caliper of the closest wheel located in the hydraulic circuit. If necessary, pump the brake pedal to extract all air from the system. Once air bubbles are no longer present in the hose, tighten the bleeder screw. (Fig. 4-75)
4. Repeat steps 2 and 3 to the next brake caliper in the brake circuit. Repeat until all brakes are bled.
5. Do a final tightness check of all caliper bleed screws before beginning cart operation. Check that brakes actuate and release properly with tractor brake pedal.



Hydraulic Jack Cylinder Replacement

⚠ WARNING

- HIGH-PRESSURE FLUIDS CAN PENETRATE THE SKIN AND CAUSE SERIOUS INJURY OR DEATH. LEAKS OF HIGH-PRESSURE FLUIDS MAY NOT BE VISIBLE. USE CARDBOARD OR WOOD TO DETECT LEAKS IN THE HYDRAULIC SYSTEM. SEEK MEDICAL TREATMENT IMMEDIATELY IF INJURED BY HIGH-PRESSURE FLUIDS.

- RELIEVE THE HYDRAULIC SYSTEM OF ALL PRESSURE BEFORE ADJUSTING OR SERVICING. SEE THE HYDRAULIC POWER UNIT OPERATOR'S MANUAL FOR PROPER PROCEDURES.

- HYDRAULIC SYSTEM MUST BE PURGED OF AIR BEFORE OPERATING TO PREVENT SERIOUS INJURY OR DEATH.

- MOVING OR ROTATING COMPONENTS CAN CAUSE SERIOUS INJURY OR DEATH. ENSURE SERVICE COVERS, CHAIN/BELT COVERS AND CLEAN-OUT DOOR ARE IN PLACE AND SECURELY FASTENED BEFORE OPERATING UNIT.

- UNHITCHING A LOADED CART CAN CAUSE SERIOUS INJURY OR DEATH DUE TO TONGUE RISING OR FALLING. ALWAYS HAVE A LOADED CART ATTACHED TO A TRACTOR. THE JACK IS INTENDED TO SUPPORT AN EMPTY CART ONLY.

- FALLING OBJECTS CAN CAUSE SERIOUS INJURY OR DEATH. DO NOT WORK UNDER THE MACHINE AT ANY TIME WHILE BEING HOISTED. BE SURE ALL LIFTING DEVICES AND SUPPORTS ARE RATED FOR THE LOADS BEING HOISTED. THESE ASSEMBLY INSTRUCTIONS WILL REQUIRE SAFE LIFTING DEVICES UP TO 2,000 LBS. SPECIFIC LOAD RATINGS FOR INDIVIDUAL LOADS WILL BE GIVEN AT THE APPROPRIATE TIME IN THE INSTRUCTIONS.

1. Park the empty unit on a firm, level surface. Block tractor and machine to keep it from moving. Set the tractor parking brake, shut off the engine and remove the ignition key. Completely disconnect the PTO from the cart and tractor.

2. Attach hydraulic jack hoses to tractor SCV.

3. Open valve and lower jack leg to ground. DO NOT raise tongue.

4. Relieve pressure on hydraulic jack circuit. See tractor operator manual for procedure.

5. Close valve.

6. Support the hydraulic jack assembly with a safe lifting device rated for a minimum of 100 lbs.

7. Remove hydraulic jack hoses from tractor SCV.

8. Remove cylinder pin (272587) and snap rings (91192) from the base end of the cylinder at the lug on top of the tongue. (FIG. 4-76)

9. Remove hydraulic jack assembly from the tongue. (FIG. 4-76)

(Continued on next page)

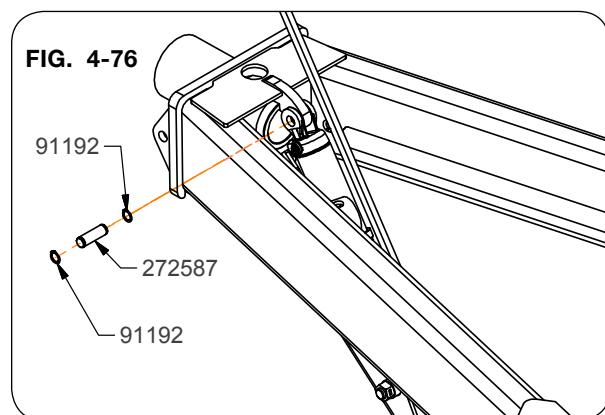

Hydraulic Jack Cylinder Replacement (continued)

- 10. On new hydraulic assembly (296289B), attach hoses (9006068) and fittings to cylinder (9009047) as shown in FIG. 4-77. The valve needs to be assembled to the hose on the base end of the cylinder. Assemble the fittings on the cylinder so they face each other, then store the hydraulic hoses on the hose caddy.

- 11. To reassemble hydraulic jack, see “Install Hydraulic Jack (Optional)” in SET UP section.

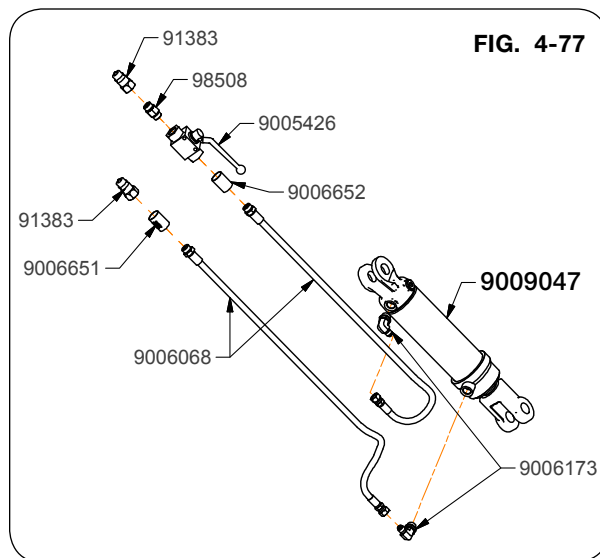

Seasonal Storage

Always open and keep open flow door, horizontal and vertical auger cleanout doors to remove any remaining grain and to allow moisture to dry.

Wash machine inside and out before storing to remove dirt and debris that can draw and collect moisture. When using pressure washers maintain an adequate distance so not to force water into bearings.

Reattach PTO brackets (296155Y) to the right hand side of the tongue and place PTO assembly on brackets.

Lubricate machine at all points outlined.

Repaint all areas where paint has been removed to keep from rust developing. Rust will affect grain flow.

Coat exposed cylinder piston rods with rust preventative material if applicable.

Inspect machine for parts that may need to be replaced so they may be ordered in the off season.

If the unit is equipped with a scale indicator or electric hydraulic controls, store these indoors in a dry location.

Close the tarp to keep debris out of the hopper.

Ensure rear access door is closed and latched and that all ladders are in storage position.



FIG. 4-78

Troubleshooting

Problem	Possible Cause	Corrective Action
No Electric Over Hydraulic (EOH) Functions work	Not getting 12 Volt power supply to the power harness in the tractor	Check the connections to the main power harness in the tractor cab, and check the 5 AMP fuse in the fuse holder of the main power harness. Replace fuse if necessary.
	Not getting good connection at Deutch connectors in the harnesses	Unplug the Deutsch connectors at the hitch point and in the extension harness (if used). Clean up the connectors with electrical contact cleaner. Make sure the connectors are aligned correctly and re-connect them.
	Not pressurizing the correct hydraulic hose	Make sure the quick couplers are properly connected to the tractor SCV and the Hydraulic Pressure line is being pressurized when engaging the tractor SCV.
Auger unfolds, but won't fold back in to transport position	Rotating Spout is not in the folding position	Rotate the spout so it is positioned straight down or forward in order to fold the auger into transport position.
	Rotating spout switch is faulty or out of adjustment	Make sure the spout is in the centered position. Press and hold the manual override button on the electric over hydraulic (EOH) valve on the auger fold cylinder while someone operates the hydraulic remote to fold the auger back to the transport position. Inspect the switch assembly near the rotating spout cylinder. The clearance between the end of the proximity switch and the barrel of the rotating spout cylinder must not exceed 1/4".
Auger unfolds part way and stops	Debris in the EOH block on the auger fold cylinder	Fold auger, remove hydraulic pressure, and remove the Coil and the cartridge valve on the EOH valve block. Remove any debris and reinstall cartridge and coil.
	Rotating Spout switch is out of adjustment or has been activated.	With the auger folded in to the lower transport rest, have someone depress and hold the switch at the vertical auger hinge plate. Use any means necessary to depress the switch without placing your hands or other body parts near the pinch points. With the switch depressed, rotate the spout to the folding position.

Troubleshooting (continued)

Problem	Possible Cause	Corrective Action
Spout rotate does not operate	7 pin connector is not plugged into tractor.	Plug in 7 pin connector to same power source as the 5 function controller.
	Proximity Switch at the auger hinge is not getting Power or Ground.	Check power and ground to the proximity switch harness on the vertical auger.
Rotating spout will not function For Serial Number B34060099 and Lower	Switch located at the hinge plate of the vertical auger is not getting depressed when the auger is unfolded	With the auger folded in to the lower transport rest, have someone depress and hold the switch at the vertical auger hinge plate. Use any means necessary to depress the switch without placing your hands or other body parts near the pinch points. With the switch depressed, activate the hydraulic remote and test the spout rotate function. Be careful to not contact the front of the cart with the rotating spout. If the spout functions properly, the switch will need to be adjusted outward so that the switch is depressed 1/4" when the auger is unfolded.
	Switch located at the hinge plate of the vertical auger is defective	With the auger folded in to the lower transport rest, have someone depress and hold the switch at the vertical auger hinge plate. Use any means necessary to depress the switch without placing your hands or other body parts near the pinch points. With the switch depressed, activate the hydraulic remote and test the spout rotate function. Be careful to not contact the front of the cart with the rotating spout. If the spout will not function, check for loose wires near the EOH block at the base of the vertical auger housing. Replace switch if necessary
Rotating spout will not function For Serial Number B34060100 & Higher	Proximity Switch at the hinge plate is not adjusted correctly	This proximity switch has a 1/4" effective operating range. The upper auger hinge plate needs to be within that range when it is unfolded in to the operating position. Adjust the proximity switch in or out in order for the sensor to activate when it is in the operating position.
	Switch located at the hinge plate of the vertical auger is not getting power, ground or is defective	Check the ground wire on the top plate of the lower vertical auger and on the left hand standard just behind the front plate of the harness. Unplug the 3 pin connector on the hinge plate proximity switch. With a multi-meter or test light, confirm that the pin in socket B has +12V constant power and socket A has +12V when the sensor is activated.
	Cartridge valve(s) on the EOH valve block are not locked in center position.	Check the cartridge valve(s) on the EOH valve block are locked in center position. Remove any debris on the cartridge valve(s). Refer to "Manual Override for Opt. Electric Over Hydraulic System" in MAINTENANCE section.
One single function will not work	Defective coil on the EOH valve for that function	Loosen the cap for the coils associated with that function on the EOH valve. Depress the button on the remote, and determine if the coils are getting magnetized. Inspect the wiring connectors to these coils, and replace the coil if necessary.
	Defective valve on the EOH valve for that function	Remove the coil and the cartridge valve on the EOH valve block for that function. Replace the valve if it doesn't operate when the coil is magnetized.
	Debris in the EOH block at the base of the vertical auger	Remove the coil and the cartridge valve on the EOH valve block. Remove any debris and reinstall cartridge and coil.
Functions continue to operate after the button on the remote is released	Tractor hydraulic flow is set too high	Turn tractor hydraulic flow down so that flow doesn't exceed 6 gallons per minute.
	Defective valve on the EOH valve for that function	Remove the coil and the cartridge valve on the EOH valve block for that function, and replace the cartridge.

Auger Switch Troubleshooting

The switch on the front of the spout assembly controls the ground for both the spout rotate front and rear. The switch near the auger hinge pin controls the ground for both the auger fold and the auger unfold. Check continuity between the switch wires to determine if the switches were out of adjustment. Adjust accordingly if needed.

The switch at the spout must have no more than a 1/4" gap between the barrel of cylinder and the switch. Verify the gap if the auger fold stops functioning during the auger fold sequence or if the auger folds even if the spout is rotated back and allows the spout to hit the hopper while folding. (FIG. 4-79)

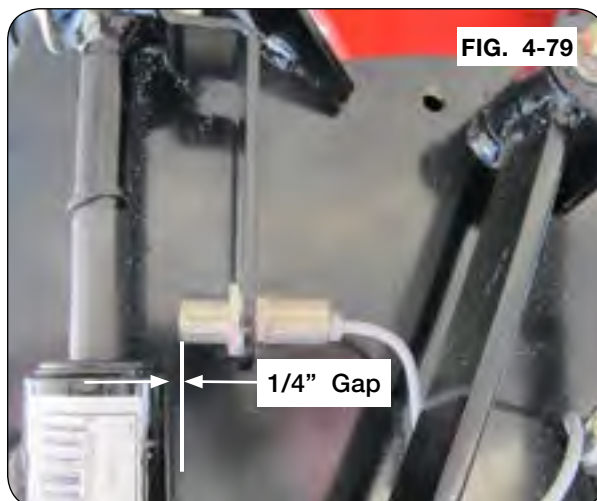

The switch at the hinge pin should be adjusted so there is 1/8" gap below the lower auger hinge plate. To maintain the 1/8" gap, adjust the hinges on the upper auger or by turning the switch in or out until the 1/8" gap is achieved. (FIG. 4-80)

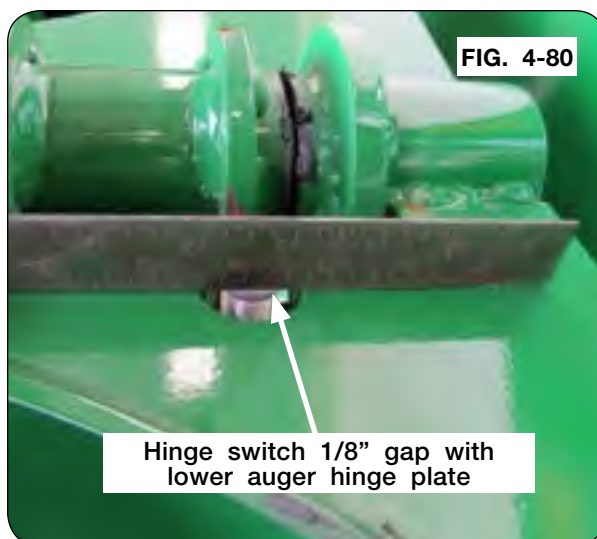

Tarp Troubleshooting Inspection & Maintenance

PROBLEM	SOLUTION
TARP SAGS IN MIDDLE AREAS	<ol style="list-style-type: none"> 1. BOWS MAY BE BENT OR ADJUSTED TOO LOW 2. MISSING OR LOOSE RIDGE STRAP REPLACE OR RETIGHTEN 3. TENSION MAY BE TOO LOOSE. U-JOINT MAY NEED TO BE ADJUSTED ON SPLINED SHAFT TO PROVIDE MORE TENSION
HOLES OR TEARS IN TARP	<ol style="list-style-type: none"> 1. CONSULT YOUR LOCAL DEALER FOR REPAIRS 2. ORDER TARP REPAIR KIT FROM DEALER 3. WHEN NEW TARP OR PARTS ARE NEEDED ALWAYS REPLACE WITH ORIGINAL PARTS

Inspection and Maintenance

WARNING

- TO PREVENT PERSONAL INJURY OR DEATH, DO NOT ALLOW ANYONE ON A CLOSED TARP. TARP SYSTEM IS NOT DESIGNED TO SUPPORT A PERSON.
- FALLING OBJECTS CAN CAUSE SERIOUS INJURY OR DEATH. REMOVE ACCUMULATED WATER/SNOW/ICE OR ANY OTHER OBJECTS FROM TARP BEFORE OPENING TARP.

IMPORTANT

- *Do not open or close tarp while moving or in high wind conditions. Damage to the tarp may occur.*
- *Tarp should not be used if it is torn or the bungee cords are frayed or show damage. Fully close tarp with tension on the latch plate to prevent water from pooling.*

Periodic preventive maintenance should be practiced. Inspect tarp and hardware often for abrasions or loosened bolts that may need adjustment and/or repair. Check bungee cords for wear and adjust tension at the beginning of the season and again half way through the season.

Tears in tarp should be addressed before further tarp operation. If water pools on tarp, adjust tension of tarp cables and/or arm springs.

If installed correctly, tarp should always operate as well as when first installed. If tarp does not pass this simple inspection, make all appropriate repairs or adjustments immediately before serious damage occurs.

Electrical System Diagram — Plug #92450

GRAIN CART WIRES

- White -- Ground
- Green -- Right Amber Flashing Lamp
- Yellow -- Left Amber Flashing Lamp
- Brown -- Tail Light
- Black -- Work Lights
- Red -- Brake Lights
- Blue -- **NOT USED**

- Black - Work Lights
- Green - RH Turn
- Yellow - LH Turn
- Brown - Tail
- White - Ground
- Red - Brake

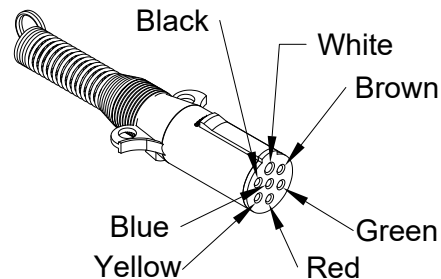

Electrical System Diagram

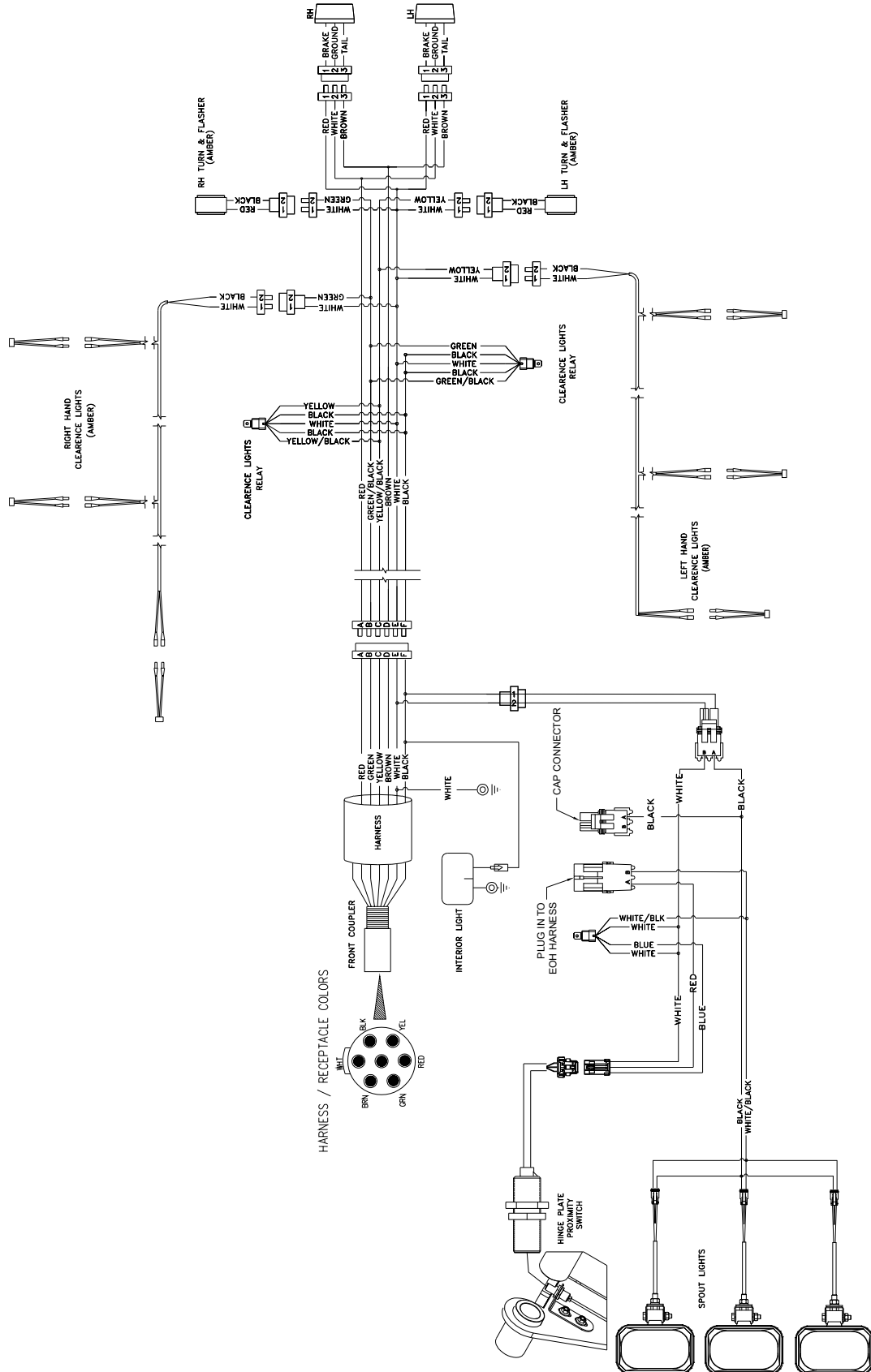

Electrical Diagram — Front Harness #9008501

- Black - Work Lights
- Green - Right Turn
- Yellow - Left Turn
- Brown - Tail Light
- White - Ground
- Red - Brake Light
- Blue - Not Used

2 Pin Shroud Weatherpack Connector
 Pin "A" - White - Ground
 Pin "B" - Black - 12V Power

2 Pin Shroud Weatherpack Connector
 Pin "A" - White - Ground
 Pin "B" - Black - 12V Power

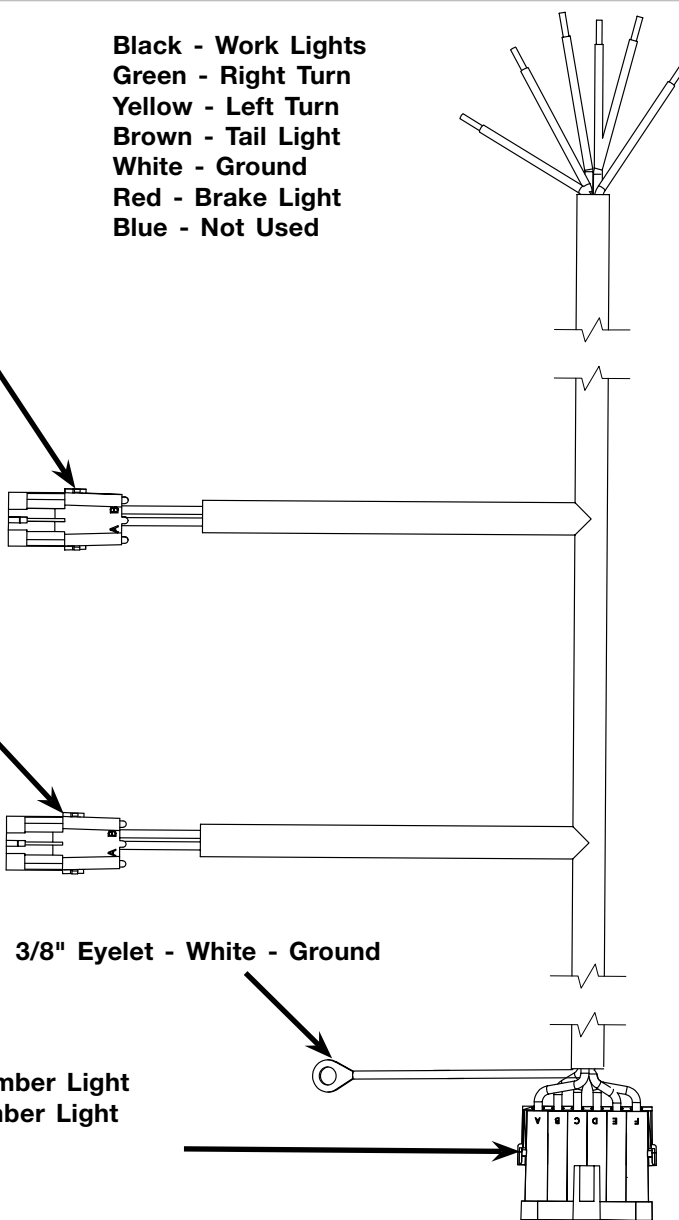

3/8" Eyelet - White - Ground

6 Pin Shroud Weatherpack Connector
 Pin "A" - Red - Brake Light
 Pin "B" - Green - Right Turn & Flasher Amber Light
 Pin "C" - Yellow - Left Turn & Flasher Amber Light
 Pin "D" - Brown - Tail Light
 Pin "E" - White - Ground
 Pin "F" - Black - +12V Work Lights

**Electrical Diagram — Rear Wiring Harness # 9009586
For SN B44630100 & Higher**

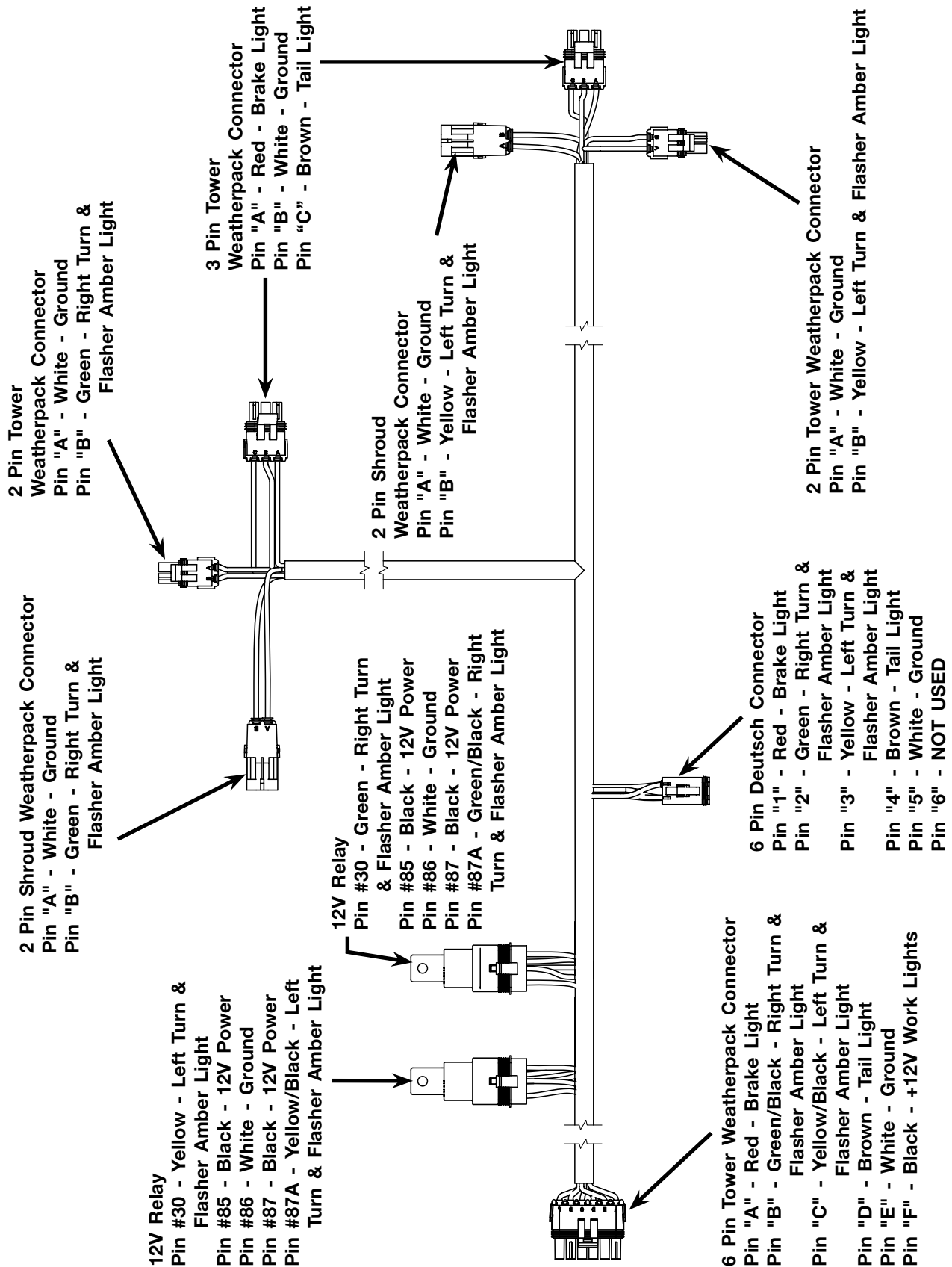

**Electrical Diagram — Rear Wiring Harness #9006480
For SN B44630099 & Lower**

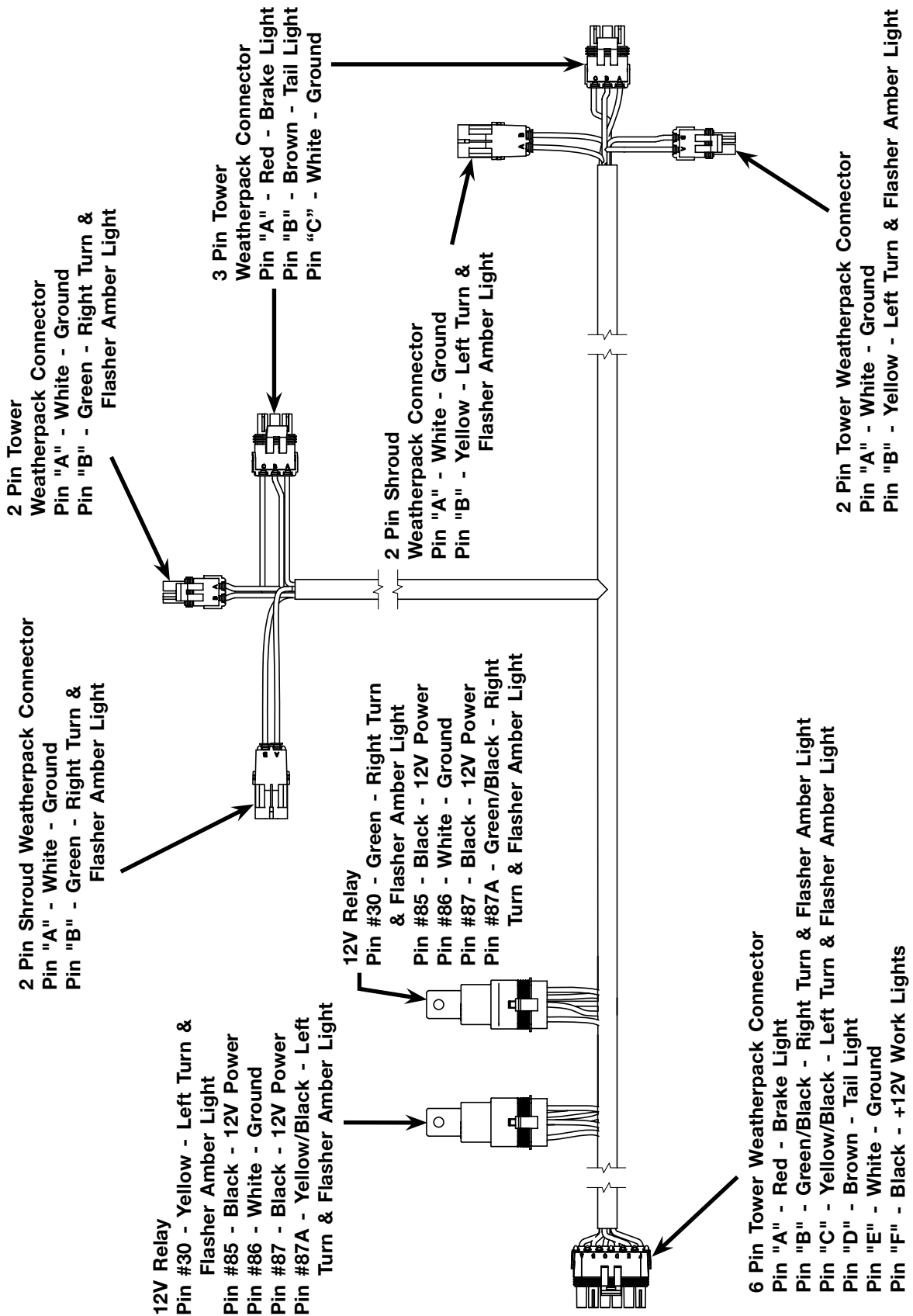

**Electrical Diagram — Running Light/Clearance Wiring Harness
#9006520**

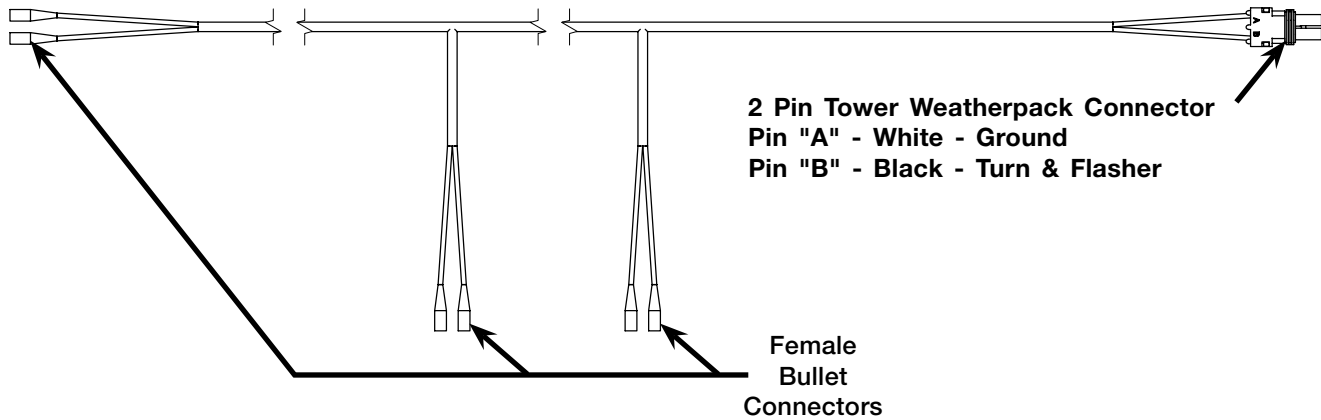

**Electrical Diagram — Work Light Wiring Harness #9008969
For SN B41030100 & Higher**

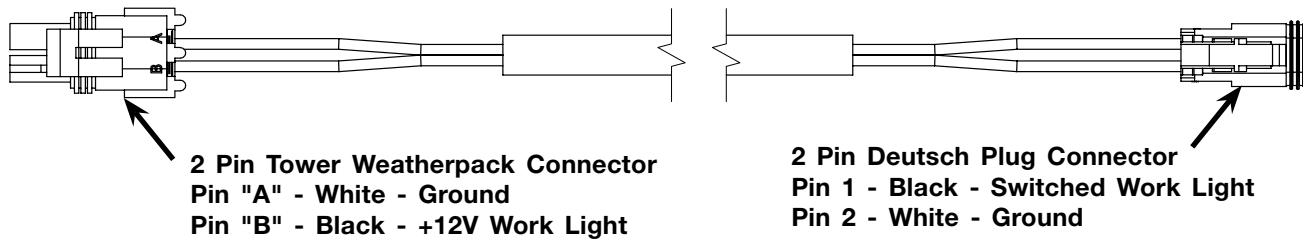

**Electrical Diagram — Work Light Wiring Harness #9008502
For SN B41030099 & Lower**

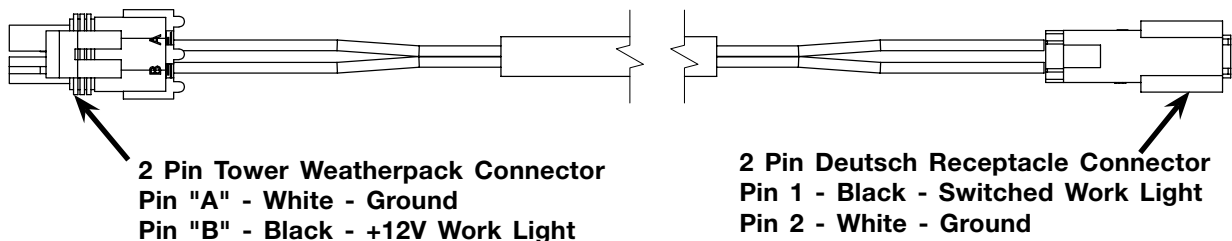

**Electrical Diagram — Auger Wiring Harness #9008956
For SN B41030100 & Higher**

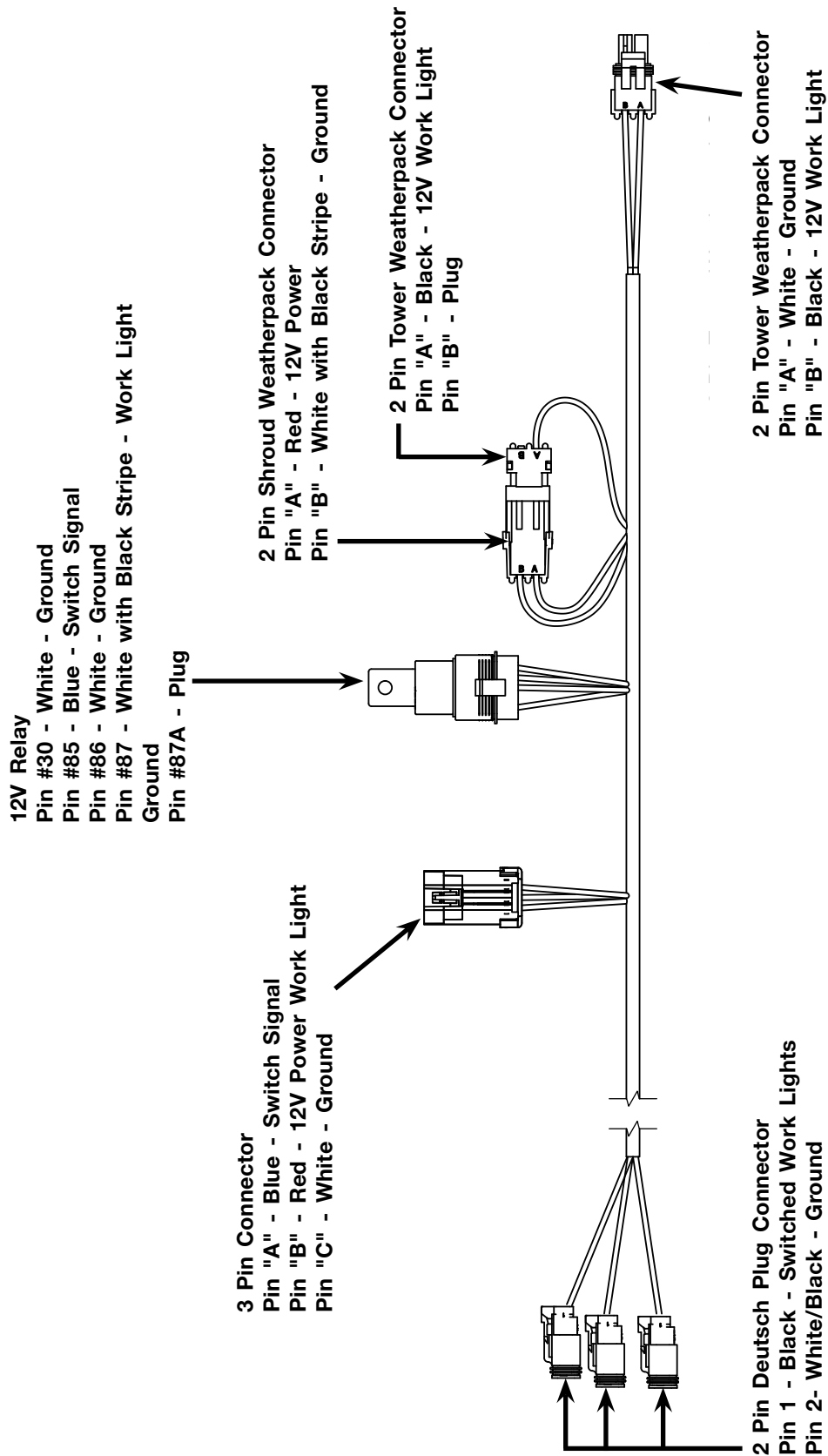

**Electrical Diagram — Auger Wiring Harness #9008107
For SN B41030099 & Lower**

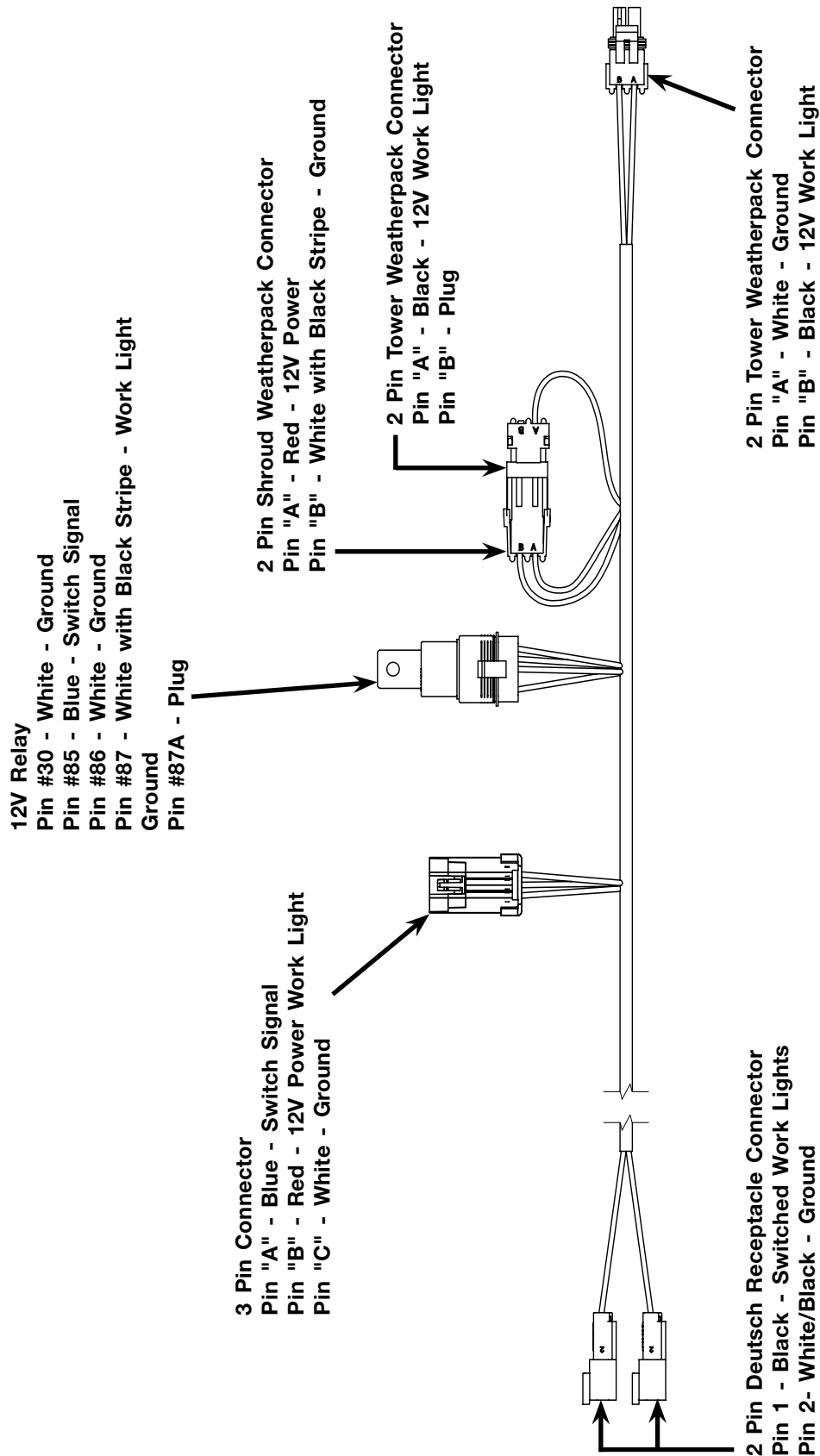

Electrical Diagram - Main Harness #9007290 (Opt.)

NOTE: For Optional Electric Over Hydraulic 5 Function Valve.

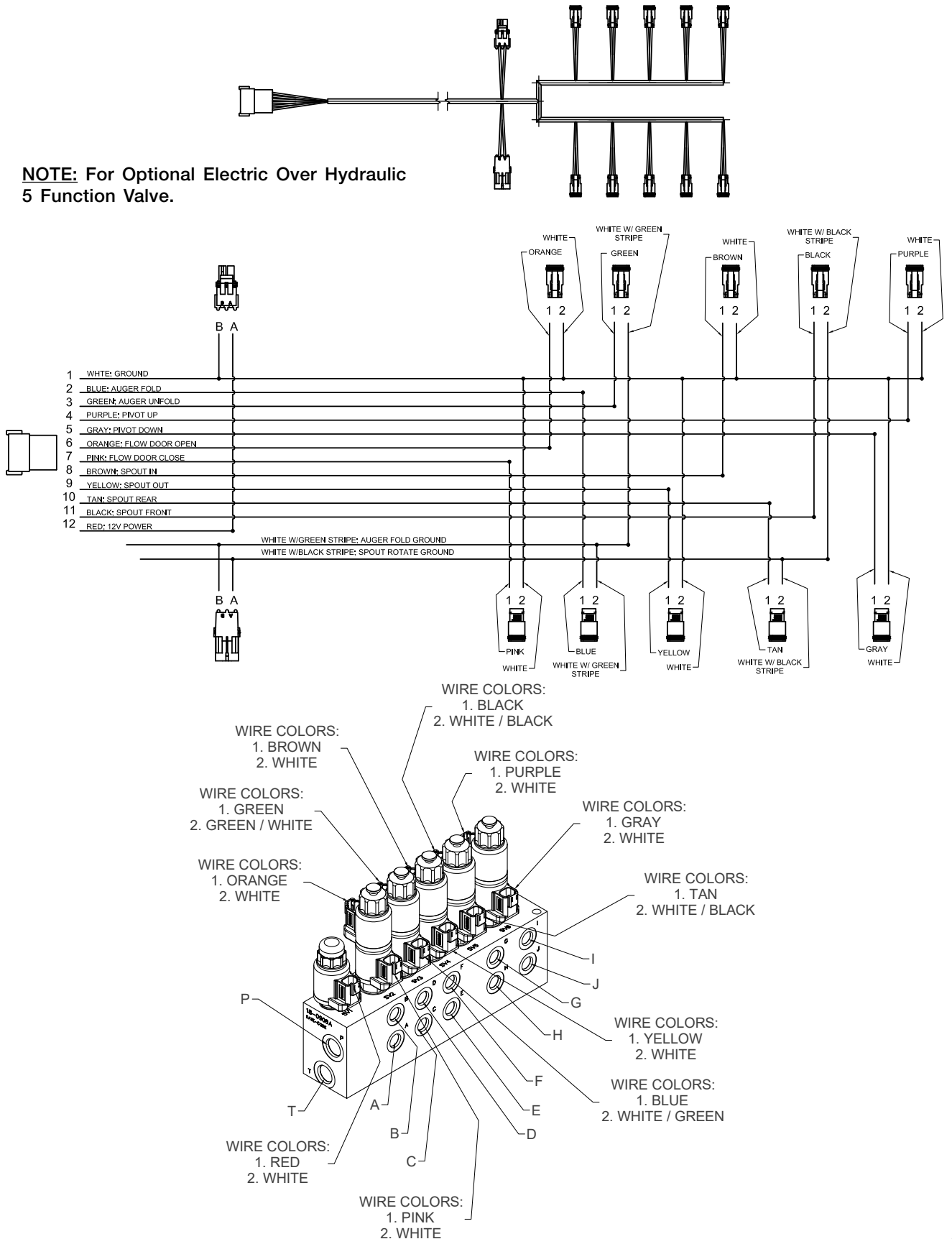

**Electrical Diagram — Amber Light -
Round Side Marker #9006107**

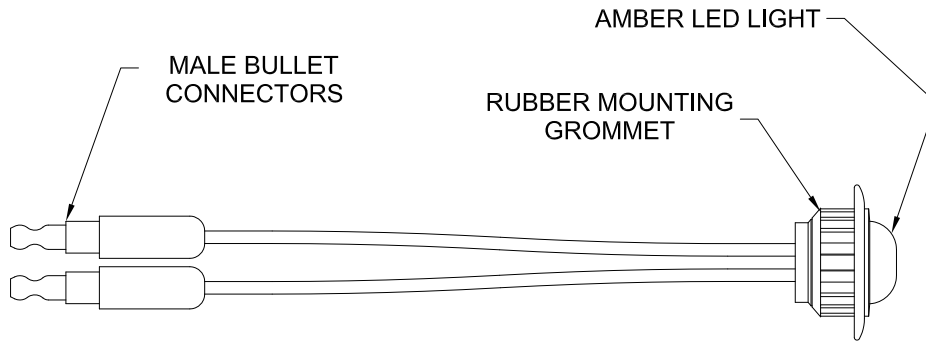

**Electrical System Schematic - Work Flood Lamp #9008957
For SN B41030100 & Higher**

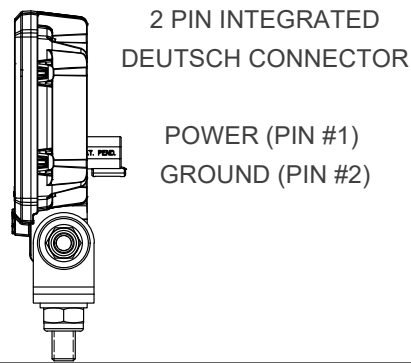

**Electrical System Schematic — Work Flood Lamp #9007186
For SN B41030099 & Lower**

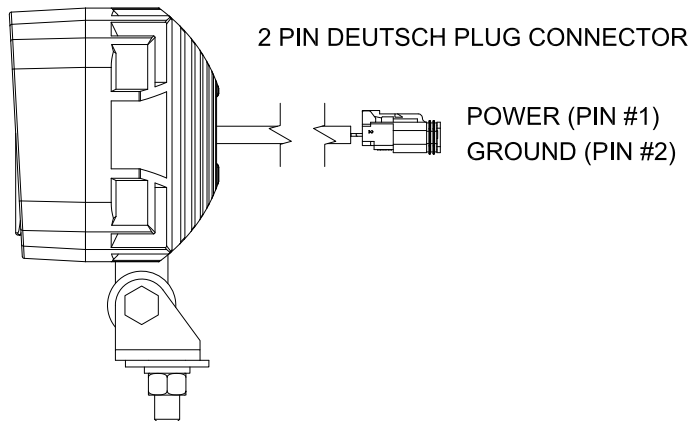

Electrical Diagram — Red Tail/Turn Light # 9006282

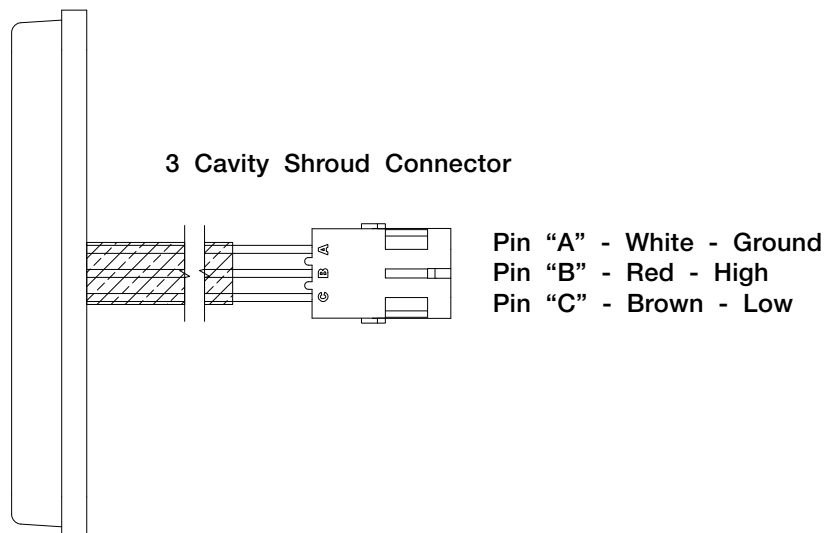

Electrical Diagram — Amber Lamp Double Face # 9005142

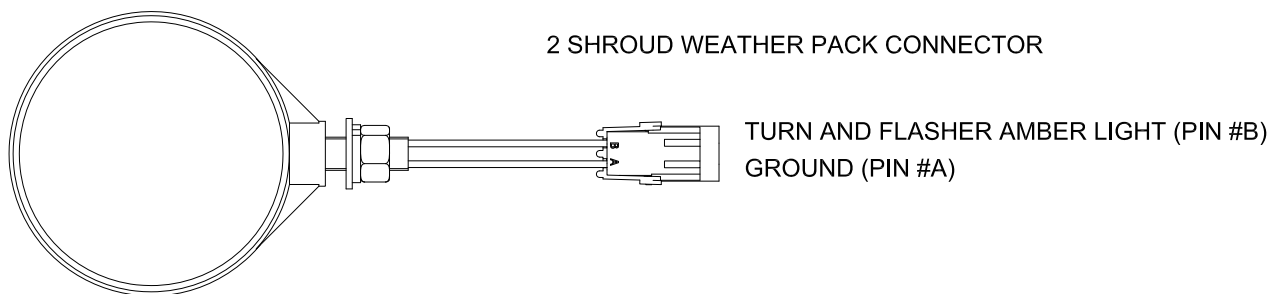

Electrical Diagram — Proximity Sensor # 9007223

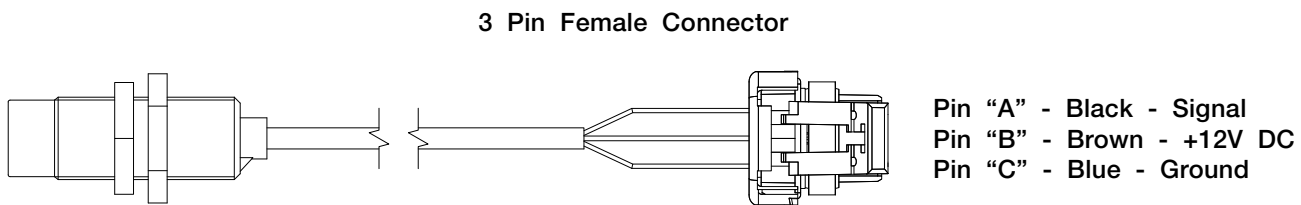

Electrical System Schematic - Diverter Harness #9007266

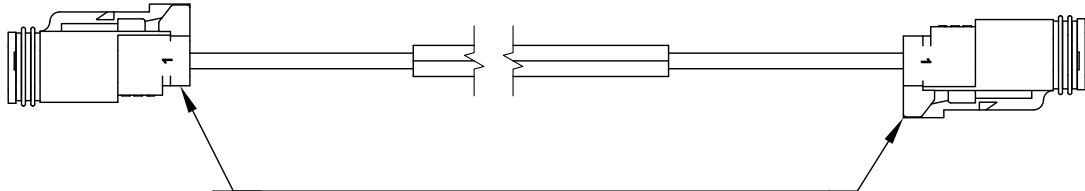

CONNECTOR TYPE: 2 PIN DEUTSCH PLUG		
PIN #	WIRE COLOR	FUNCTION
1	RED	+12V POWER
2	WHITE	GROUND

Electrical System Schematic - Adapter Harness, AG to 7-Blade Connector #9009843 (Optional - Rear Hitch) For SN B44630100 & Higher

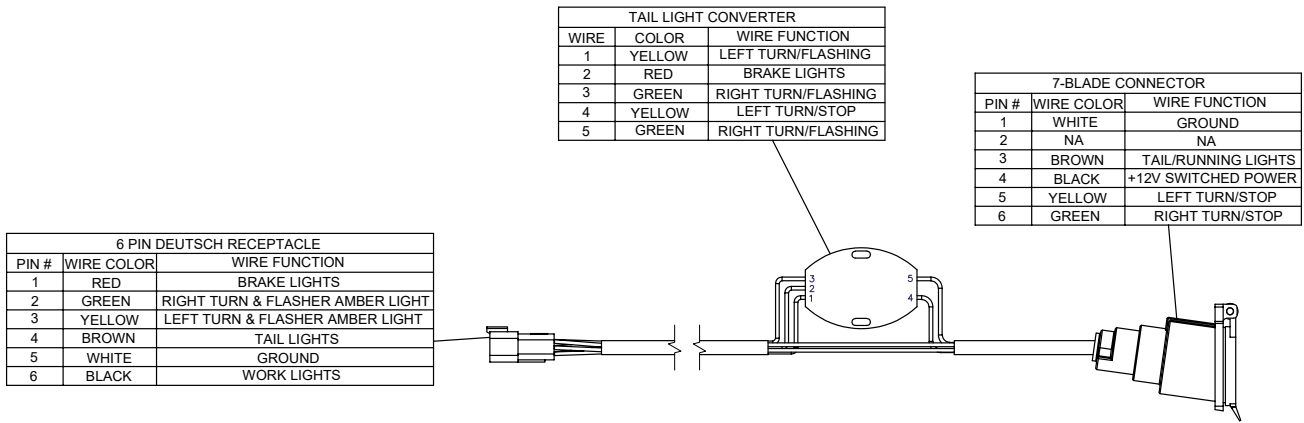

TAIL LIGHT CONVERTER		
WIRE	COLOR	WIRE FUNCTION
1	YELLOW	LEFT TURN/FLASHING
2	RED	BRAKE LIGHTS
3	GREEN	RIGHT TURN/FLASHING
4	YELLOW	LEFT TURN/STOP
5	GREEN	RIGHT TURN/FLASHING

7-BLADE CONNECTOR		
PIN #	WIRE COLOR	WIRE FUNCTION
1	WHITE	GROUND
2	NA	NA
3	BROWN	TAIL/RUNNING LIGHTS
4	BLACK	+12V SWITCHED POWER
5	YELLOW	LEFT TURN/STOP
6	GREEN	RIGHT TURN/STOP

6 PIN DEUTSCH RECEPTACLE		
PIN #	WIRE COLOR	WIRE FUNCTION
1	RED	BRAKE LIGHTS
2	GREEN	RIGHT TURN & FLASHER AMBER LIGHT
3	YELLOW	LEFT TURN & FLASHER AMBER LIGHT
4	BROWN	TAIL LIGHTS
5	WHITE	GROUND
6	BLACK	WORK LIGHTS

Electrical Over Hydraulic (EOH) System Schematic 5 Function Optional

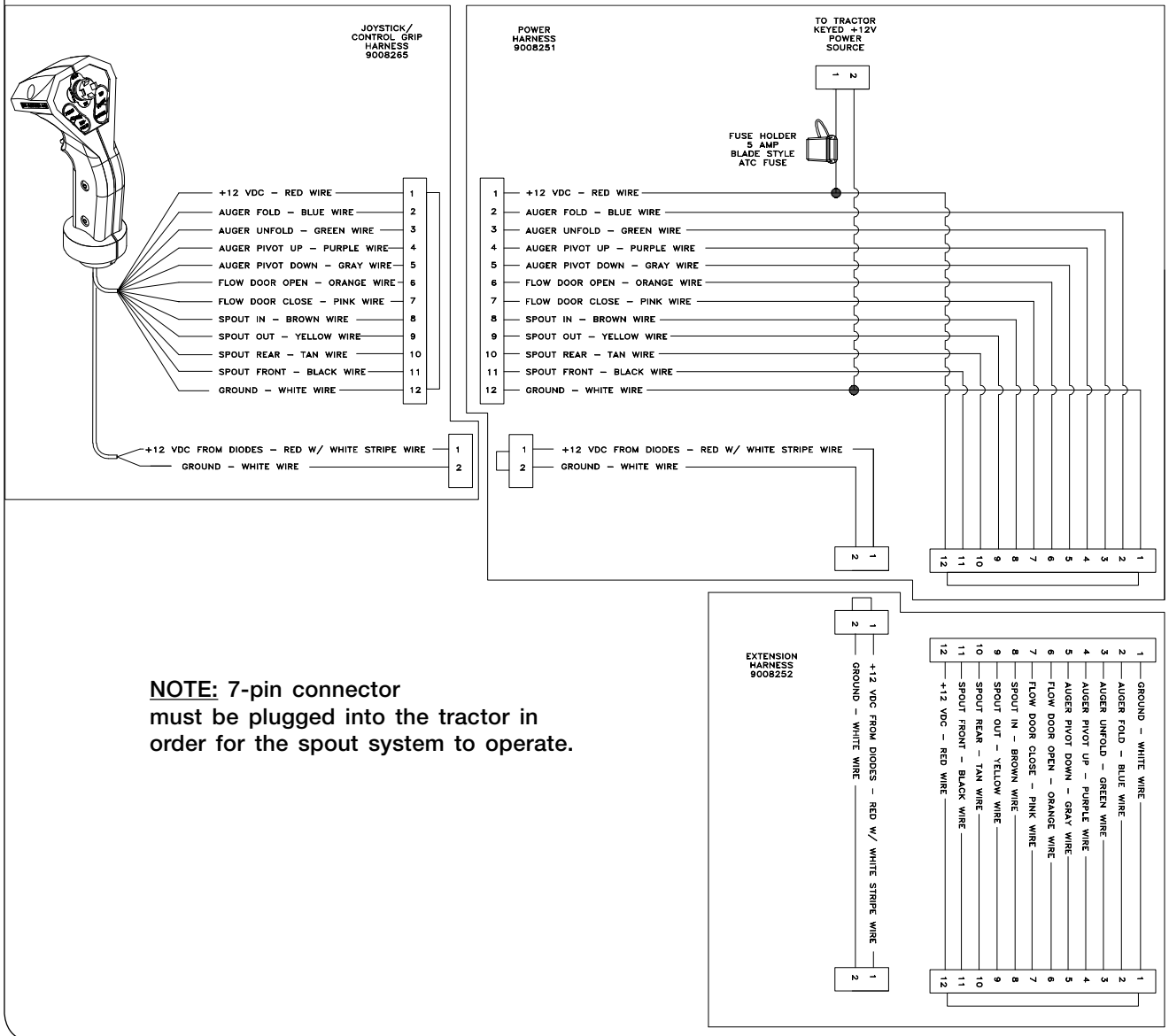

Optional Electric Over Hydraulic Valve Electric Schematic 5 Spool

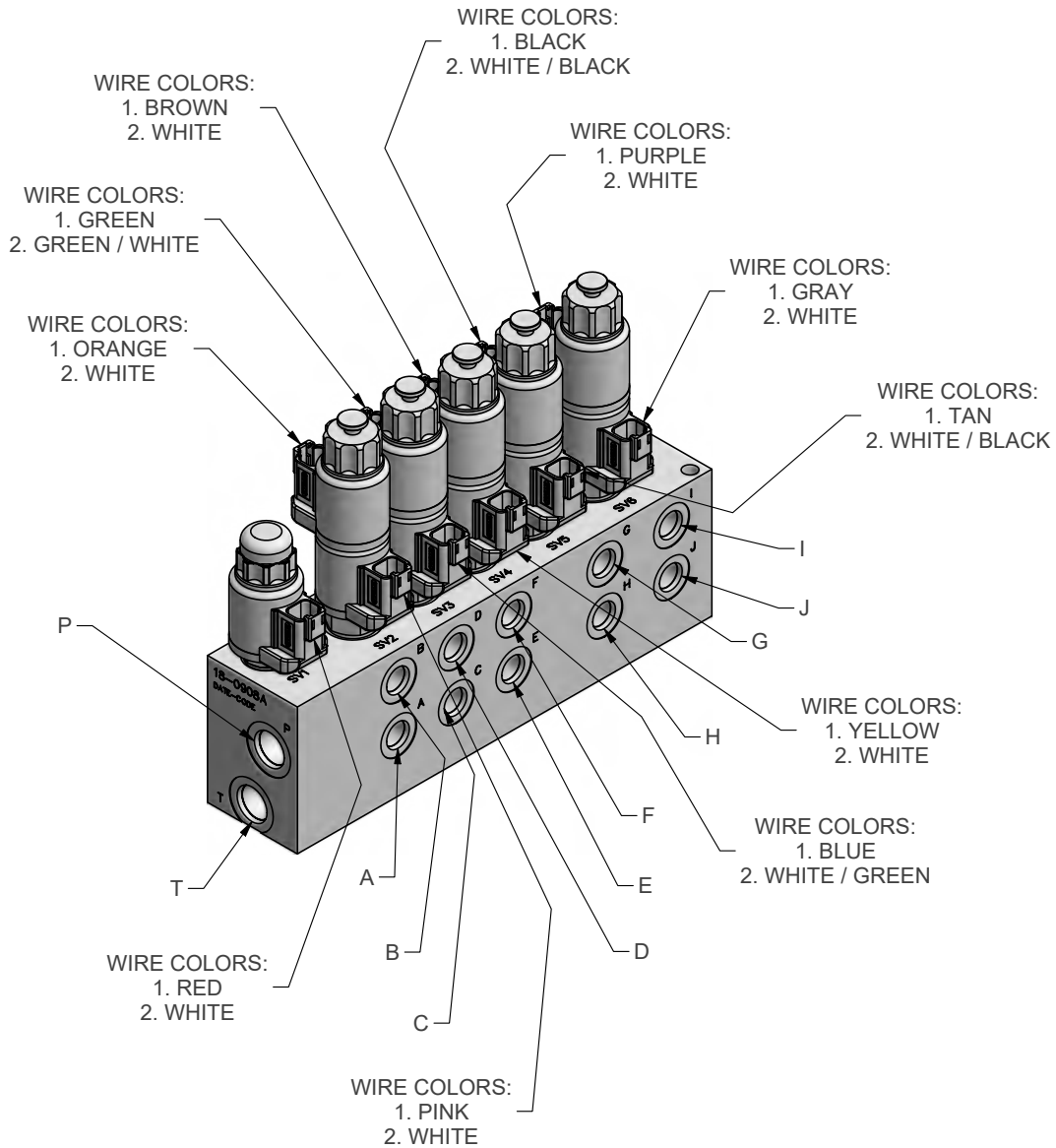

PORT	END OF CYLINDER	FUNCTION
A	BUTT END	FLOW DOOR
B	RAM END	FLOW DOOR
C	RAM END	AUGER FOLD
D	BUTT END	AUGER FOLD
E	RAM END	SPOUT TILT OUT
F	BUTT END	SPOUT TILT IN
G	RAM END	JOYSTICK / SPOUT ROTATE BACK
H	BUTT END	JOYSTICK / SPOUT ROTATE FRONT
I	BUTT END	AUGER PIVOT DOWN
J	RAM END	AUGER PIVOT UP
P		TRACTOR PRESSURE
T		TRACTOR RETURN

Electrical System Schematic - Optional Wireless Electric Tarp For SN B43110100 & Higher

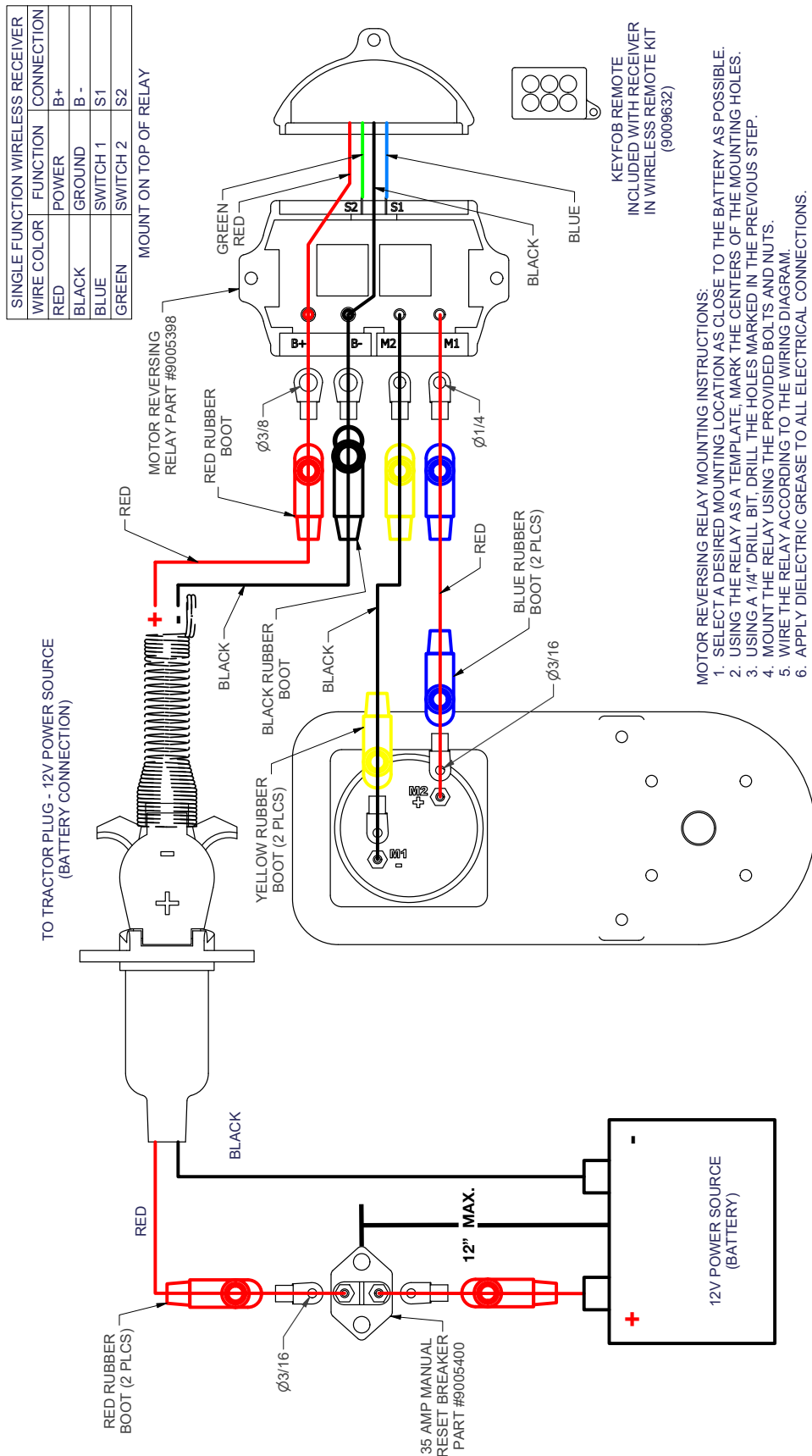

- MOTOR REVERSING RELAY MOUNTING INSTRUCTIONS:**
1. SELECT A DESIRED MOUNTING LOCATION AS CLOSE TO THE BATTERY AS POSSIBLE.
 2. USING THE RELAY AS A TEMPLATE, MARK THE CENTERS OF THE MOUNTING HOLES.
 3. USING A 1/4" DRILL BIT, DRILL THE HOLES MARKED IN THE PREVIOUS STEP.
 4. MOUNT THE RELAY USING THE PROVIDED BOLTS AND NUTS.
 5. WIRE THE RELAY ACCORDING TO THE WIRING DIAGRAM.
 6. APPLY DIELECTRIC GREASE TO ALL ELECTRICAL CONNECTIONS.

NOTE: See separate electric tarp manual for additional information.

WIRELESS ELECTRIC TARP

**Electrical System Schematic - Optional Electric Tarp
For SN B43110099 & Lower**

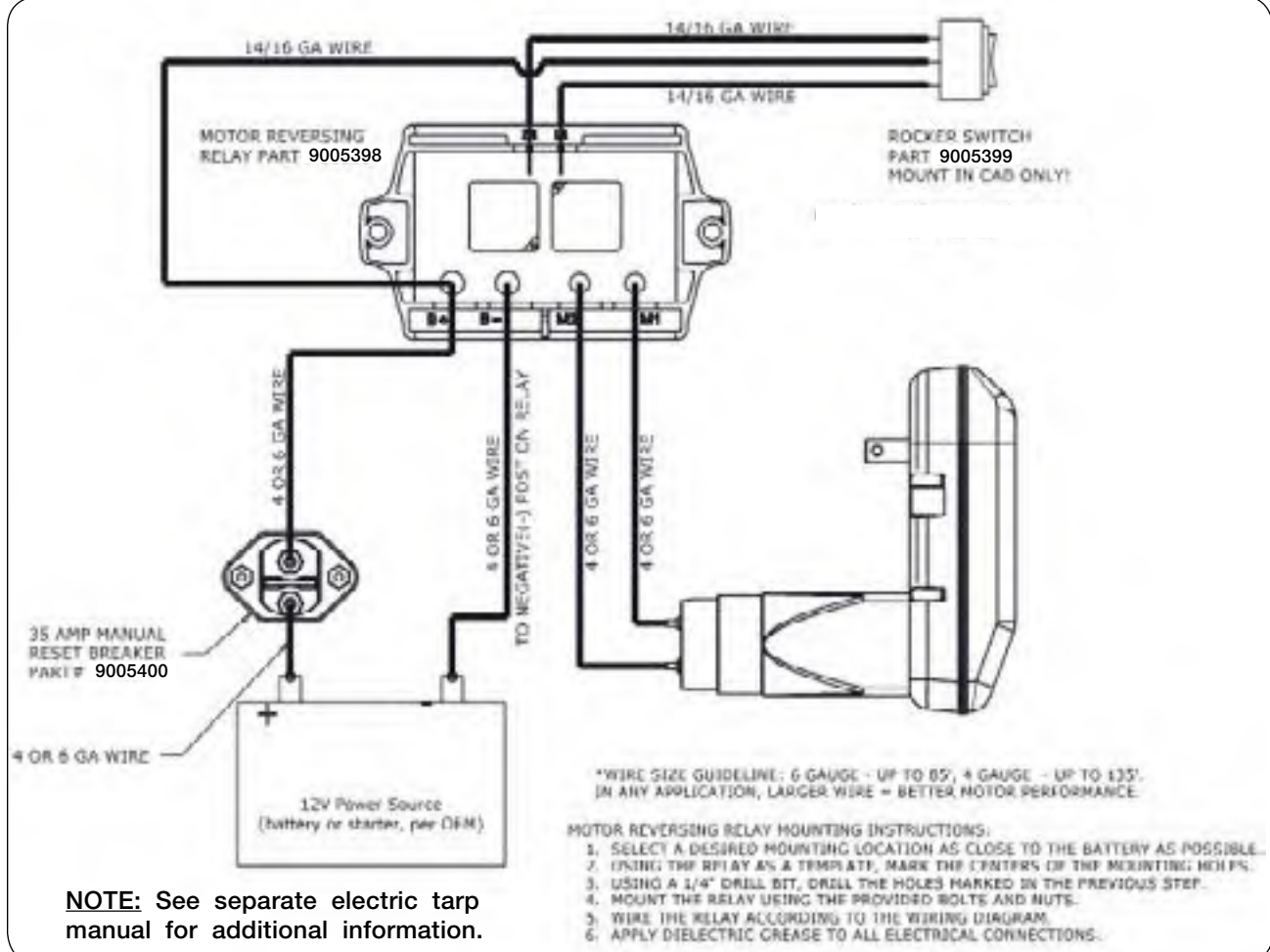

NOTE: See separate electric tarp manual for additional information.

Braking System Schematic

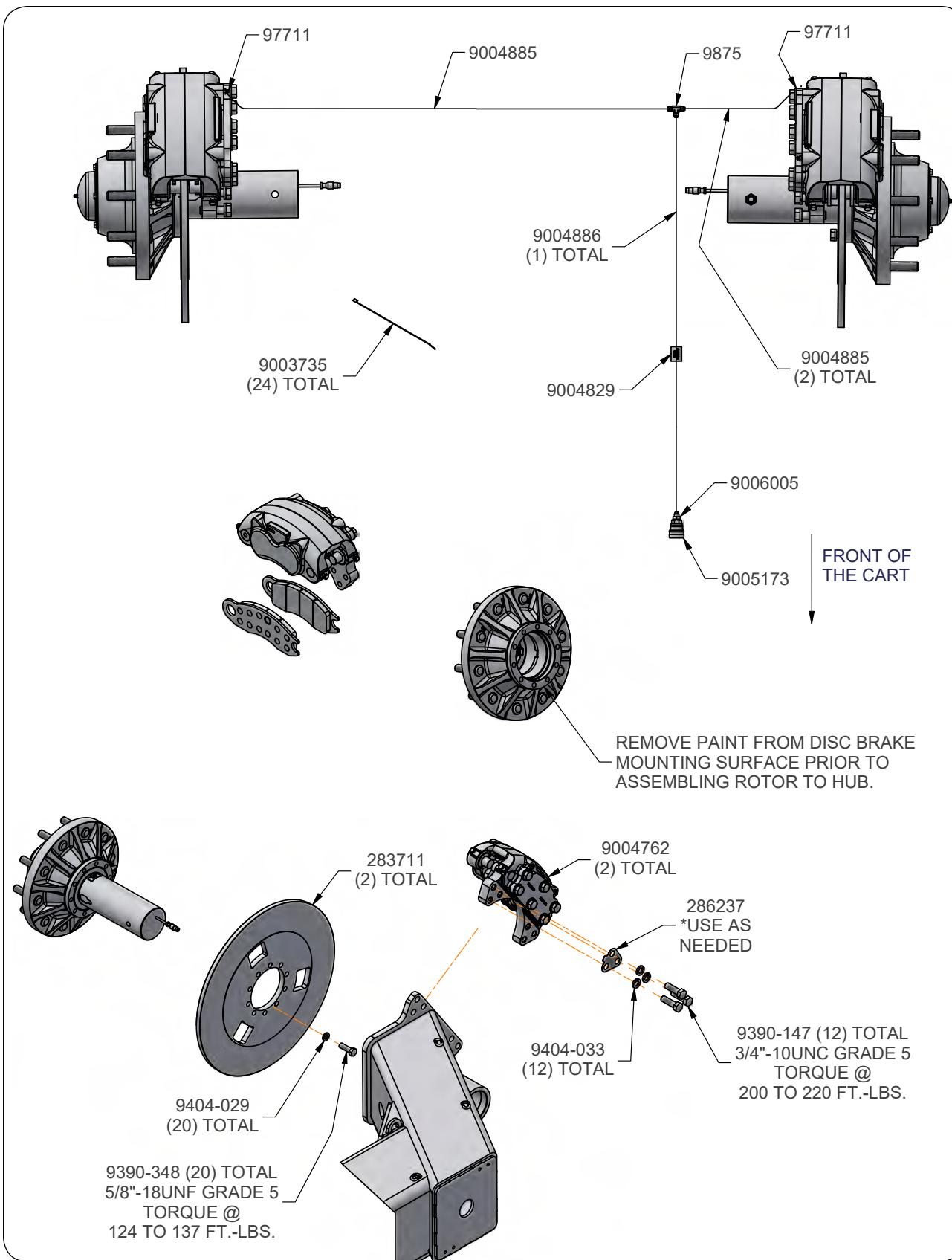

Complete Torque Chart

Cap screws - Grade 5

NOTE:

- Grade 5 cap screws can be identified by three radial dashes on the head.
- For wheel torque requirements, refer to Wheels and Tires.
- Tighten U-bolts evenly and equally to have the same number of threads exposed on each end.



SIZE	FOOT POUNDS	NEWTON METERS
1/4-20	8-10	11-13
1/4-28	9-11	12-15
5/16-18	15-17	20-23
5/16-24	17-19	23-26
3/8-16	25-28	34-38
3/8-24	28-31	38-42
7/16-14	40-45	54-61
7/16-20	45-50	61-68
1/2-13	62-68	84-92
1/2-20	68-75	92-102
9/16-12	90-98	122-133
9/16-18	100-110	134-148
5/8-11	120-135	162-183
5/8-18	124-137	168-186
3/4-10	200-220	270-300
3/4-16	210-230	285-310
7/8-9	330-350	425-475
7/8-14	360-380	460-515
1-8	500-525	675-710
1-14	540-560	730-760
1 1/8-7	600-635	815-860
1 1/8-12	665-700	920-950
1 1/4-7	850-895	1150-1215
1 1/4-12	940-990	1275-1340
1 3/8-6	1125-1175	1525-1590
1 3/8-12	1280-1335	1735-1810
1 1/2-6	1500-1560	2035-2115
1 1/2-12	1685-1755	2285-2380

IMPORTANT

- Follow these torque recommendations except when specified in text.

Complete Torque Chart

Capscrews - Grade 8

NOTE:

- Grade 8 capscrews can be identified by six radial dashes on the head.
- For wheel torque requirements, refer to Wheels and Tires.
- Tighten U-bolts evenly and equally to have the same number of threads exposed on each end.



SIZE	FOOT POUNDS	NEWTON METERS
5/16-18	20-22	27-30
5/16-24	21-23	28-31
3/8-16	35-39	47-53
3/8-24	36-41	49-55
7/16-14	54-58	73-78
7/16-20	55-60	75-80
1/2-13	82-88	110-120
1/2-20	94-99	125-135
9/16-12	127-134	170-180
9/16-18	147-155	199-210
5/8-11	160-170	215-230
5/8-18	165-175	225-235
3/4-10	280-295	380-400
3/4-16	330-365	445-495
7/8-9	410-430	555-580
7/8-14	420-440	570-595
1-8	630-650	850-880
1-14	680-700	920-950
1 1/8-7	900-930	1220-1260
1 1/8-12	930-950	1260-1290
1 1/4-7	1250-1300	1695-1760
1 1/4-12	1280-1320	1735-1790

IMPORTANT

- *Follow these torque recommendations except when specified in text.*

Hydraulic Fittings - Torque and Installation

SAE Flare Connection (J. I. C.)

1. Tighten nut with finger until it bottoms the seat.
2. Using a wrench, rotate nut to tighten. Turn nut 1/3 turn to apply proper torque.

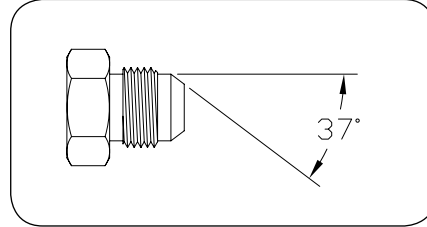

SAE Straight Thread O-Ring Seal

1. Ensure jam nut and washer are backed up to the back side of smooth portion of elbow adapter.
2. Lubricate o-ring.
3. Thread into port until washer bottoms onto spot face.
4. Position elbows by backing up adapter.
5. Tighten jam nut.

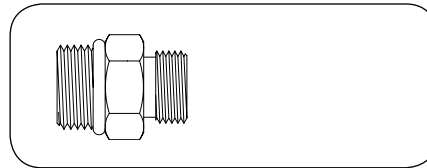

Section V

Parts

Please visit www.unverferth.com/parts/ for the most current parts listing.

Decals.....	5-2
Touch-Up Paint.....	5-5
Front End Components.....	5-6
Side Ladder Components - SN B41030100 & Higher.....	5-8
Rear Ladder Components - SN B44630100 & Higher.....	5-10
Rear Access Door Components - SN B44630100 & Higher.....	5-11
Hopper Cross Brace & Cleanout Door Components.....	5-12
Sideboards - SN B43120100 & Higher.....	5-14
Sideboards - SN B43120099 & Lower.....	5-16
Tandem Axle Components.....	5-18
Tandem Hub Components.....	5-20
Tandem Wheels & Tires.....	5-21
Tandem Grease Bank Assembly.....	5-21
Brake Components (Optional).....	5-22
Track Axle Components.....	5-24
Track Panel Kit Components.....	5-25
Hopper Flow Door Components.....	5-26
Front and Rear Flow Door Components.....	5-28
Flow Door Indicator Assembly.....	5-30
Rear Runner Brace Components.....	5-32
Vertical Auger Flighting Components.....	5-34
Horizontal Auger Components - SN B40450100 & Higher.....	5-36
Horizontal Auger Components - SN B40450100 & Lower.....	5-38
Auger Fold Linkage Components.....	5-40
Downspout Components.....	5-44
Rotating Spout Components.....	5-46
Optional Spout Rotate Switch Assembly Components.....	5-48
Lower Auger Cleanout Door, Covers & Rest Components.....	5-50
Lower Auger Linkage Components.....	5-52
Lower Auger Idler Assembly Components.....	5-54
Lower Auger Retainer Assembly Components.....	5-56
Cut Out Clutch PTO Assembly - Benzi.....	5-58
Cut Out Clutch Assembly - Benzi.....	5-59
Cut Out Clutch PTO Assembly - Walterscheid.....	5-60
Cut Out Clutch Assembly - Walterscheid.....	5-61
Gearbox Components.....	5-62
EOH Valve Assembly Components - Optional.....	5-64
EOH Valve Functions and Wire Locations - Optional.....	5-66
EOH Tractor Circuit Hydraulic Components - Optional.....	5-67
EOH Spout Rotate Option and Tilt Hydraulic Components.....	5-68
Auger Pivot Hydraulic Components.....	5-70
Auger Fold Hydraulic Components.....	5-71
Flow Door Circuit Hydraulic Components.....	5-72
Cylinders.....	5-74
Hopper Rear Electrical Components.....	5-76
Electrical Components.....	5-78
End Caps, Tarp Bows & Mounting Brackets.....	5-80
Weather Guard Tarp.....	5-82
Hydraulic Jack - Kit #296289B (Optional).....	5-84
Rear Drop Hitch (Optional) - SN B44630100 & Higher.....	5-85
Video System (Optional).....	5-86

FOR SCALE, TRACK, UHARVEST, ELECTRIC TARP, AND / OR WATER DELIVERY SYSTEM INFORMATION, PLEASE REFER TO THE INDIVIDUAL MANUALS.

Decals

Please visit www.unverferth.com/parts/ for the most current parts listing.

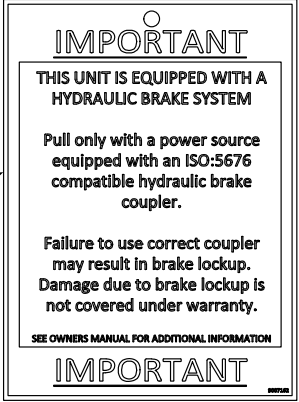
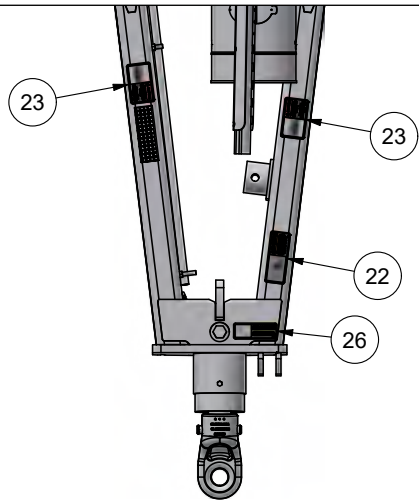

(Units with Brake Option)

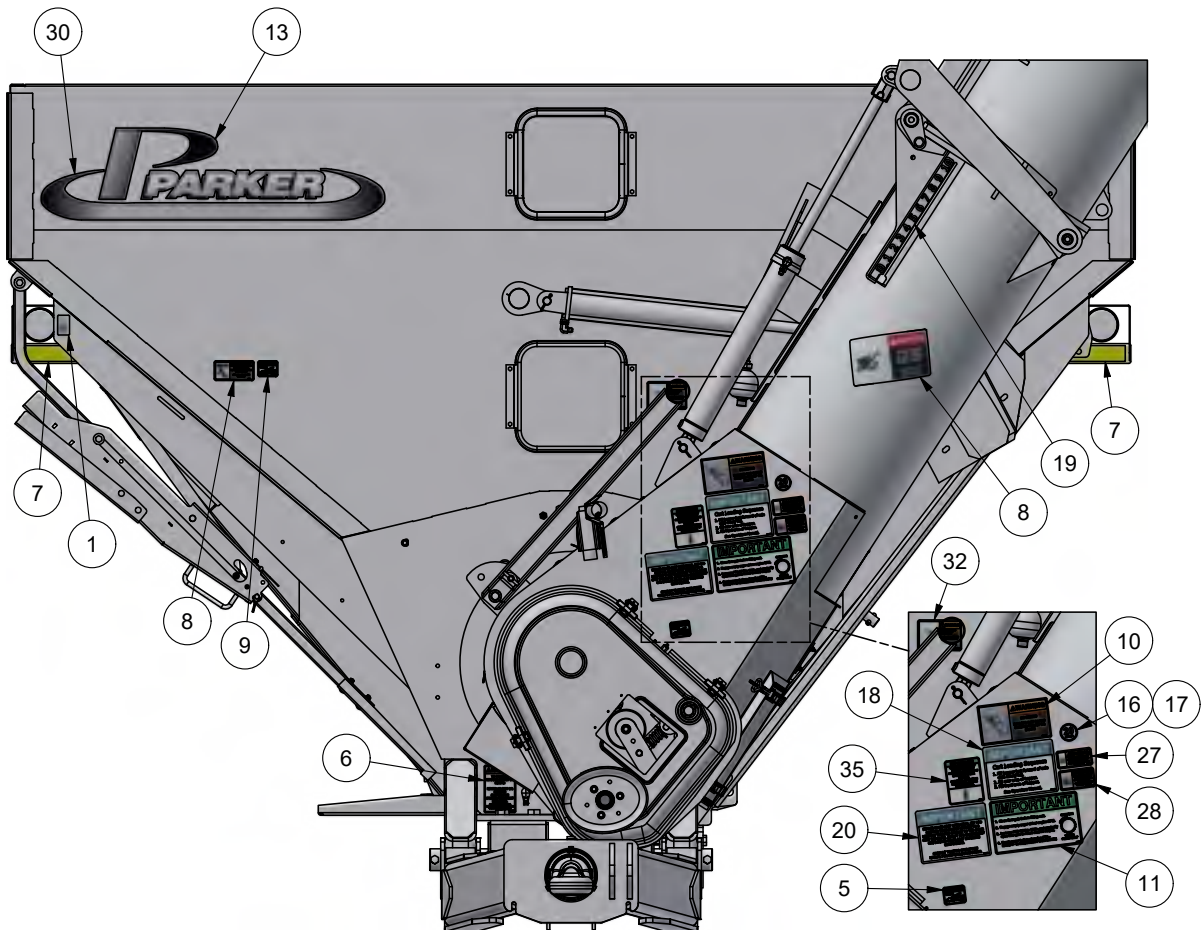

Decals (continued)

Please visit www.unverferth.com/parts/ for the most current parts listing.

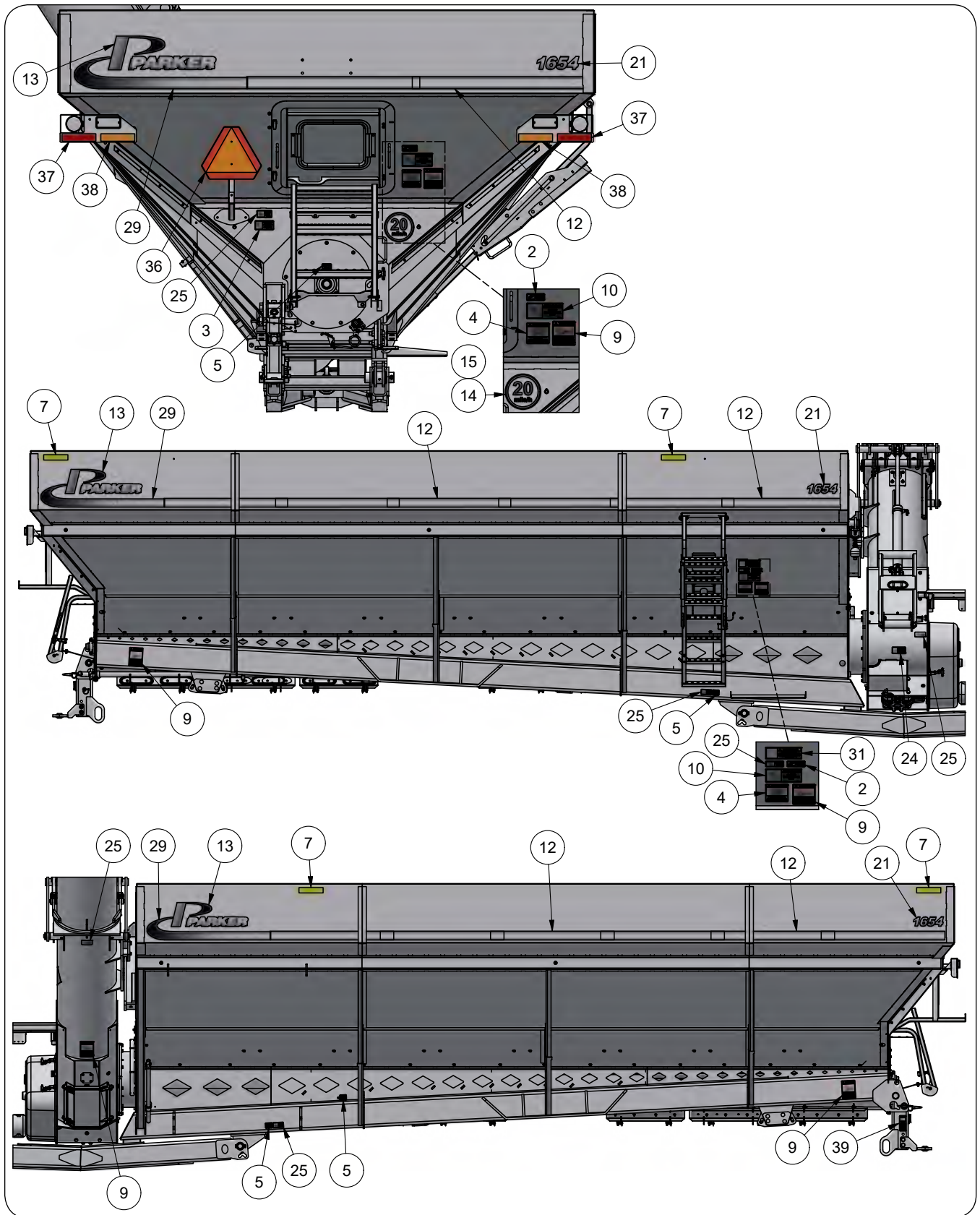

Decals (continued)

Please visit www.unverferth.com/parts/ for the most current parts listing.

ITEM	PART NO.	DESCRIPTION	QTY	NOTES
1	91605	Decal, FEMA	1	
2	95008	Decal, CAUTION (Slippery Surface)	2	
3	98229	Decal, WARNING (Falling Equipment)	2	
4	9003478	Decal, DANGER Never Play	2	
5	9008947	Decal, Grease Every Month	6	
6	9005971	Decal, WARNING (Never Adjust/Service Suspension...)	1	
7	9003127	Reflector 2" x 9" =AMBER=	5	
8	9003474	Decal, DANGER (Electrical Lines)	1	
9	9003475	Decal, DANGER (Cut & Crush)	4	
10	9003476	Decal, WARNING (No Riders)	2	
11	9003477	Decal, IMPORTANT (Operation)	1	
12	9004175	Decal, Parker Stripe (3 1/4" x 46")	14	
13	9004172	Decal, Parker Logo (9" x 29")	4	
14	9008714	Decal, Rear SIS 20MPH	1	
15	9008720	Decal, Rear SIS 30KPH	1	
16	9008715	Decal, Front SIS 20MPH	1	
17	9008721	Decal, Front SIS 30KPH	1	
18	9004966	Decal, IMPORTANT (Cart Loading)	1	
19	9006601	Decal, Flow Control Indicator	1	
20	9008151	Decal, IMPORTANT (PTO Engagement)	1	
21	9008498	Decal, Model Parker 1654	3	
22	94094	Decal, WARNING (Tongue Rise)	1	
23	95046	Decal, DANGER (Entanglement)	2	
24	95445	Decal, DANGER (Do Not Use Hands)	1	
25	95839	Decal, WARNING (Pinch Point)	6	
26	97575	Decal, CAUTION (Transport Chain)	1	
27	97961	Decal, WARNING (Read Manual)	1	
28	TA1-906109-0	Decal, WARNING (Moving Parts Crush/Cut)	1	
29	9004174	Decal, Parker Left Swoosh (8 1/2" x 46")	3	
30	9004173	Decal, Parker Double Swoosh (6 1/2" x 44 1/2")	1	
31	9009168	Decal, WARNING (Ladder Lock Pin)	1	
32	900024	Decal, WARNING (High Pressure Oil)	1	
33	94754	Decal, UM Wheel Systems	1	
34	9007162	Information Tag Brakes Option	1	
35	9008543	Decal, IMPORTANT (Spout Rotate)	1	Optional
36	TA510514	SMV Emblem	1	
37	9003126	Reflector 2" x 9" =RED=	2	
38	9003125	Decal 2" x 9" =FLUORESCENT=	2	
39	9009646	Decal, WARNING (Towing Capacity)	1	

Touch-Up Paint

Please visit www.unverferth.com/parts/ for the most current parts listing.

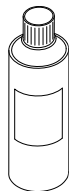

PAINT	SPRAY
Black	97013
Green	97015
Red	97301
Primer, Gray	9500082
Silver Mist	97012

Front End Components

Please visit www.unverferth.com/parts/ for the most current parts listing.

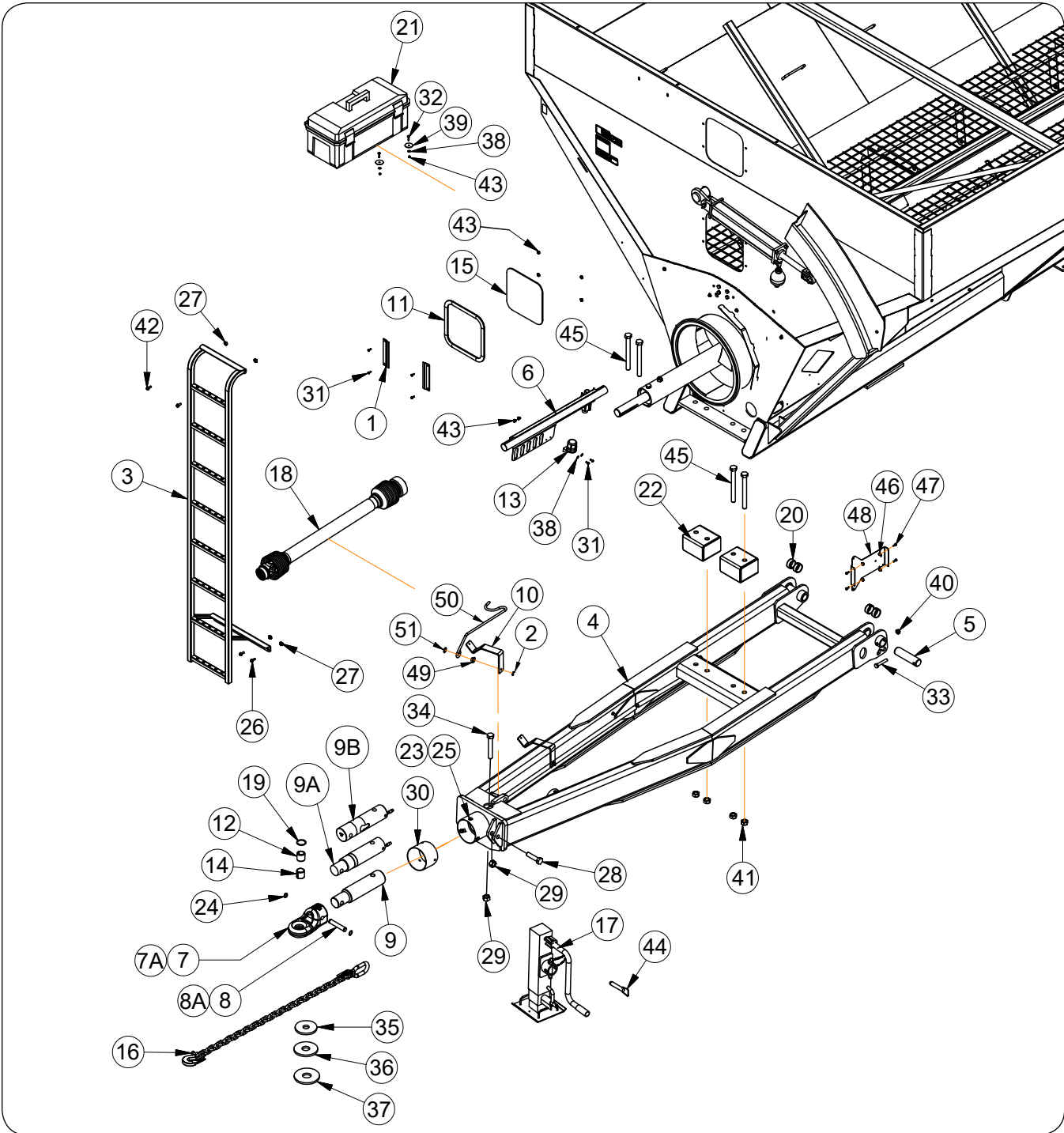

ITEM	PART NO.	DESCRIPTION	QTY	NOTES
1	250461B	Window Bracket =Black=	6	
2	91267	Flange Nut, 1/2"-13UNC Grade 5	2	For SN B41030100 & Higher
	9388-052	Carriage Bolt, 3/8"-16UNC x 1 1/4" G5		For SN B41030099 & Lower
3	293257B	Front Mount Ladder Weldment =Black=	1	For SN B40450100 - B41030099
	282300B			For SN B40450099 & Lower
4	276815G	Tongue Weldment =Green=	1	
	276815R	Tongue Weldment =Red=		

Front End Components

Please visit www.unverferth.com/parts/ for the most current parts listing.

ITEM	PART NO.	DESCRIPTION	QTY	NOTES
5	273368	Pin, 2" Dia. x 7 3/4"	2	
6	272639B	Hose Caddy Replacement Kit (Black)	1	
7	282875B	CAT 4 Hitch =Black=	1	Standard
7A	282329B	CAT 5 Hitch =Black=	1	Optional
8	282876	CAT 4 Hitch Pin, 1" Dia. x 5 1/2"	1	Standard
8A	281691	CAT 5 Hitch Pin, 1" Dia. x 7 3/8"	1	Optional
9	284780	Hitch Bar 3 3/4" Dia. x 16 3/8" CAT 4	1	Standard
	271894	Hitch Bar 3 3/4" Dia. x 14 5/8" CAT 5		Optional
9A	9004910	Scale Hitch Bar 3 3/4" Dia. with 16 ft. Cable CAT 4	1	Standard (CAT 4 Track)
	9004913	Scale Hitch Bar 3 3/4" Dia. with 16 ft. Cable CAT 4	1	Standard (CAT 4 Tandem)
9B	9008119	Scale Hitch Bar 3 3/4" Dia. with 16 ft. Cable CAT 5	1	Optional (CAT 5 Track)
	9008135	Scale Hitch Bar 3 3/4" Dia. with 16 ft. Cable CAT 5	1	Optional (CAT 5 Tandem)
10	296155Y	PTO Bracket =Yellow=	2	
11	271952	Window Moulding	3	
12	9001917	Tension Bushing 2" OD x 1 1/2" ID x 2"	1	
13	9001968	Trailer Connector Holder	1	
14	9002130	Split Tension Bushing, 2" OD x 1 3/4" ID x 2"	1	
15	9002544	Window	3	
16	9004898	Transport Chain 41,000#	1	Standard
	PF1238-19	Transport Chain 61,000#		Replaces Standard Grain Cart Transport Chain At Front Of Cart If Equipped With Optional Rear Hitch
17	9005011	Jack	1	
18	9008527	PTO Assembly Complete (Benzi)	1	U-Joint Color is Gray
	9005230	PTO Assembly Complete (Walterscheid)		U-Joint Color is Yellow
19	9005259	O-Ring	4	
20	9005473	Split Tension Bushing, 2 3/8" Dia.	4	
21	9008634	Box Storage	1	
22	273976G	Spacer Weldment =Green=	2	
	273976R	Spacer Weldment =Red=		
23	9390-053	Capscrew, 3/8"-16UNC x 3/4" Grade 5	3	
24	91192	Retaining Ring, 1"	2	
25	9005376	U-Nut	3	
26	91262	Large Flange Screw, 3/8"-16UNC x 1" Grade 5	2	For SN B40450099 & Lower
27	91263	Large Flange Nut, 3/8"-16 UNC Grade 5	4	
28	91299-191	Capscrew, 1"-8UNC x 4" Grade 8	1	
29	92199	Center Locknut, 1"-8UNC	2	
30	271891B	Shield Tube =Black=	1	
31	9390-003	Capscrew, 1/4"-20UNC x 3/4" Grade 5	14	
32	9390-006	Capscrew, 1/4"-20UNC x 1 1/4" Grade 5	2	
33	9390-130	Capscrew, 5/8"-11UNC x 3 1/2" Grade 5	2	
34	91299-195	Capscrew, 1"-8UNC x 6" Grade 8	1	
35	281663	Poly Wear Shoe For CAT 3	1	Optional
36	281898	Poly Wear Shoe For CAT 4	1	Standard
37	281899	Poly Wear Shoe For CAT 5	1	Optional
38	9405-064	Flat Washer, 1/4"	4	
39	94763	Fender Washer, 2" Dia.	2	
40	95905	Center Locknut, 5/8"-11UNC	2	
41	9663	Locknut, 1"-8UNC Grade 5	4	
42	95585	Large Flange Screw, 3/8"-16UNC x 3/4" Grade 5	2	For SN B40450099 & Lower
43	9936	Locknut, 1/4"-20UNC Grade 5	8	
44	9007632	Jack Pin, 7/8" Dia. x 4 7/8" with Chain	1	
45	9390-197	Capscrew, 1"-8UNC x 7" Grade 5	4	
46	97189	Large Flange Hex Nut 1/4"-20UNC	4	
47	97420	Flange Screw 1/4"-20UNC x 3/4" Grade 5	4	
48	296421B	GCM Mount Bracket =Black=	1	
49	296156	PTO Holder Bushing 1 3/8" ID	1	
50	295840	Driveline Storage Rod	1	
51	9405-088	Flat Washer 1/2"	1	

Side Ladder Components - For SN B41030100 & Higher

Please visit www.unverferth.com/parts/ for the most current parts listing.

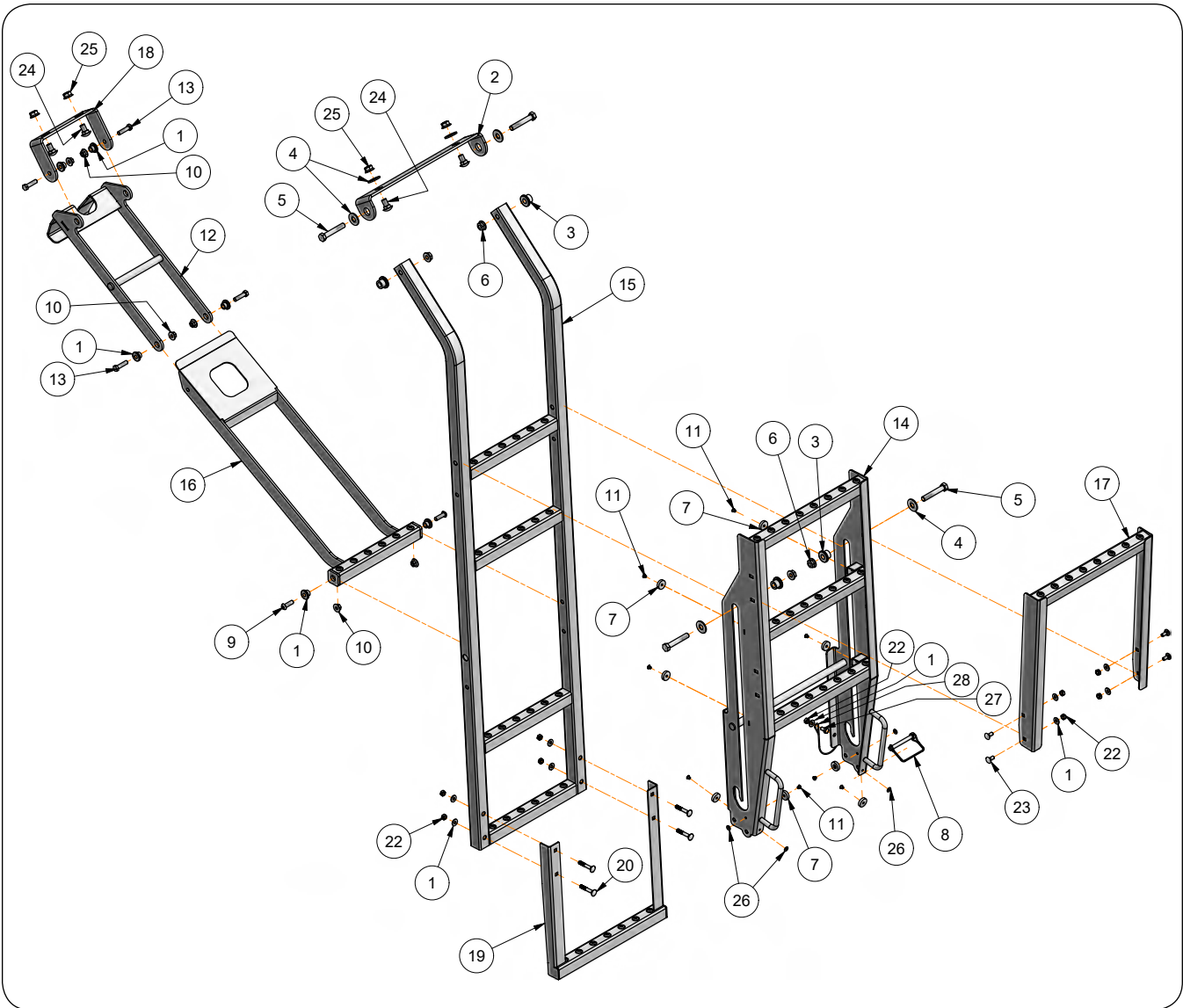

Side Ladder Components- For SN B41030100 & Higher

Please visit www.unverferth.com/parts/ for the most current parts listing.

ITEM	PART NO.	DESCRIPTION	QTY	NOTES
1	2003029	Nylon Bushing, .625" OD x .406" ID x .380"	6	
2	289294B	Plate-Bracket, Ladder =Black=	1	
3	2003030	Nylon Bushing, .875" OD x .531" ID x .563"	4	
4	9405-088	Flat Washer, 1/2" USS	6	
5	9390-107	Capscrew, 1/2"-13UNC x 3" G5	4	
6	9003397	Lock Nut/Top, 1/2"-13UNC	4	
7	TA620384	Plastic Stop, 1" Dia. x .250"	8	
8	9005305	Lynch Pin 3/8" Dia. x 3"	1	
9	99985	Button Head Socket, 3/8"-16UNC x 1 1/4"	2	
10	9008159	Lock Nut/Top, 3/8"-16UNC	6	
11	9003503	Rivet 3/16 X 1/4	8	
12	289284B	Ladder Link Weldment =Black=	1	
13	9390-057	Capscrew, 3/8"-16UNC x 1 1/2" G5	4	
14	289328B	Ladder Extension Weldment =Black=	1	
15	289326B	Ladder Weldment =Black=	1	
16	289715B	Step Weldment =Black=	1	
17	289707B	Ladder Extension Weldment =Black=	1	
18	289840B	Ladder Bracket =Black=	1	
19	289844B	Ladder Weldment =Black=	1	
20	9388-029	Carriage Bolt, 5/16"-18UNC x 2" G5	4	
21	9405-064	Flat Washer, 5/16" ID USS	9	
22	901527	Lock Nut/Center, 5/16"-18UNC	9	
23	9388-024	Carriage Bolt, 5/16"-18UNC x 3/4" G5	4	
24	9388-102	Carriage Bolt, 1/2"-13UNC x 1" G5	4	
25	91267	Flange Nut 1/2-13 UNC G5	4	
26	9004998	Rivet Burr, 3/16"	4	
27	9390-027	Capscrew, 5/16"-18UNC x 5/8" G5	1	
28	97879	Nylon Lanyard	1	

Rear Ladder Components For SN B44630100 and Higher

Please visit www.unverferth.com/parts/ for the most current parts listing.

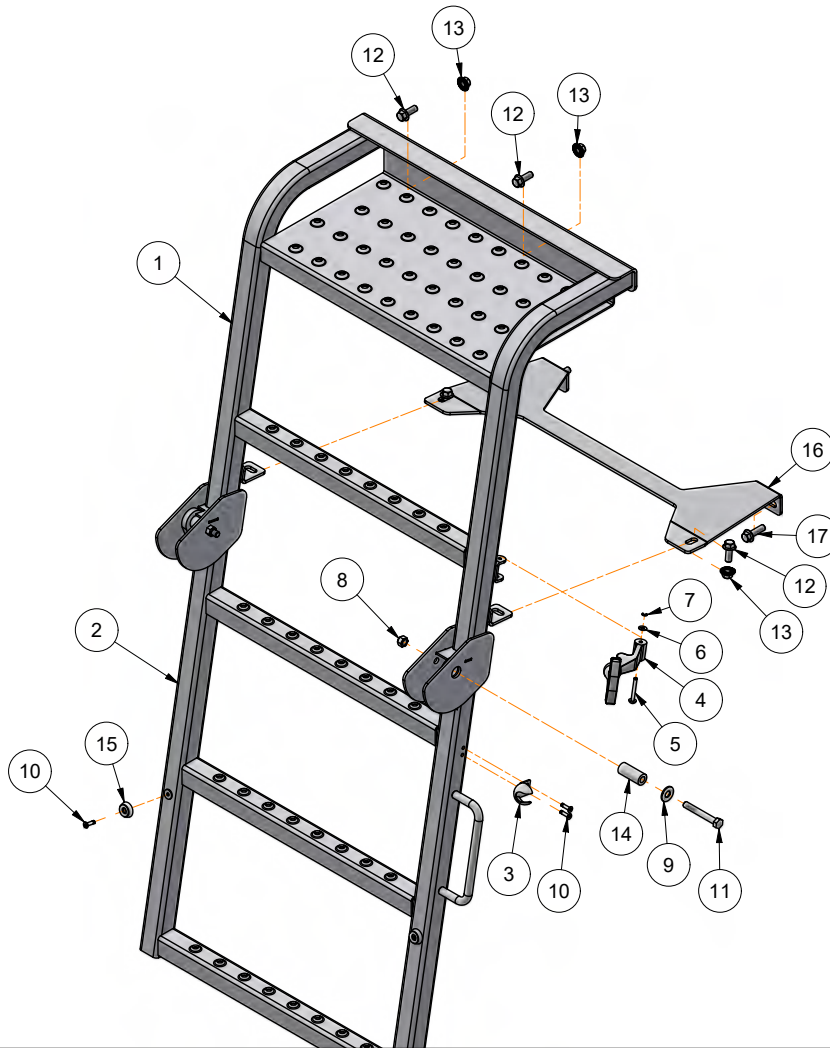

ITEM	PART NO.	DESCRIPTION	QTY	NOTES
1	296417B	Upper Ladder Weldment =Black=	1	
2	296429B	Lower Ladder Weldment =Black=	1	
3	900059	Draw Latch Keeper	1	
4	900060	Draw Latch Handle	1	
5	900066	Pin 3/16" x 1 1/2"	1	
6	900067	Washer 1/2"	1	
7	900068	E-Ring	1	
8	9928	Lock Nut 3/8-16UNC"	2	
9	9405-076	Flat Washer 3/8" USS	2	
10	TA0-908386-0	3/16" Stainless Rivet	4	
11	9390-062	Capscrew 3/8"-16UNC x 2 3/4" Grade 5	2	
12	91262	Flange Screw 3/8"-16UNC x 1" Grade 5	4	
13	91263	Flange Nut 3/8"-16UNC	4	
14	295137	Pivot Bushing	2	
15	9003850	Bumper	2	
16	296585B	Ladder Bolt Plate =Black=	1	
17	9003259	Flange Screw 3/8"-16UNC x 1 1/4" Grade 5	2	

Rear Access Door Components For SN B44630100 and Higher

Please visit www.unverferth.com/parts/ for the most current parts listing.

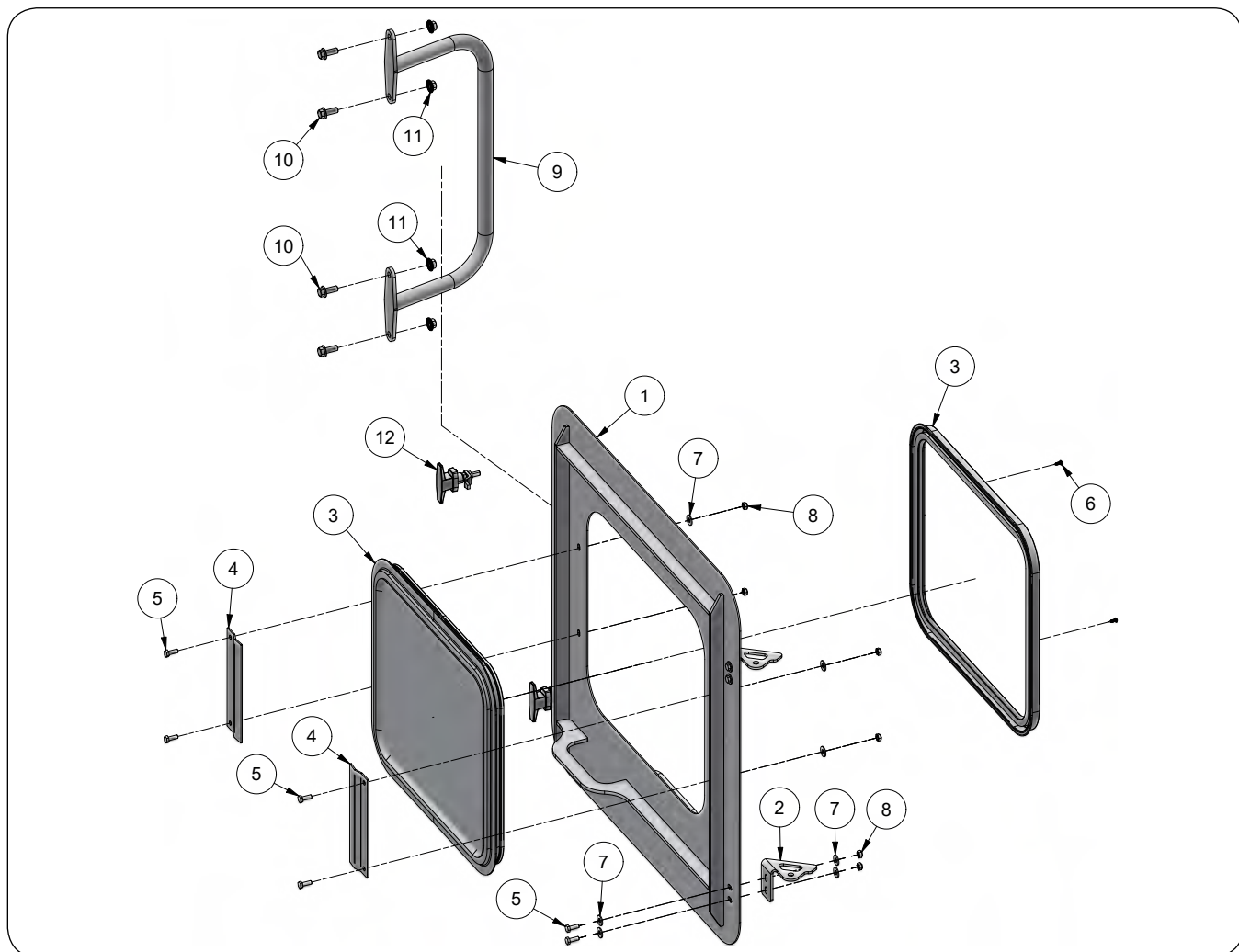

ITEM	PART NO.	DESCRIPTION	QTY	NOTES
1	256527R	Rear Access Door Weldment =Red=	1	
	256527G	Rear Access Door Weldment =Green=		
2	256670	Rear Access Door Hinge	2	
3	9008680	Window and Trim Assembly	1	
4	294121B	Window Bracket =Black=	2	
5	9390-003	Capscrew 1/4"-20UNC x 3/4" Grade 5	8	
6	9008933	Phillips Head Screw #8-18 x 1/2"	10	
7	9405-064	Flat Washer 1/4"USS	8	
8	9936	Locknut 1/4"-20UNC	8	
9	296534B	Access Door Handle Weldment =Black=	1	
10	91262	Flange Screw 3/8"-16UNC x 1" Grade 5	4	
11	91263	Flange Nut 3/8"-16UNC	4	
12	9009768	Compression Draw Latch	2	

Hopper Cross Brace & Cleanout Door Components

Please visit www.unverferth.com/parts/ for the most current parts listing.

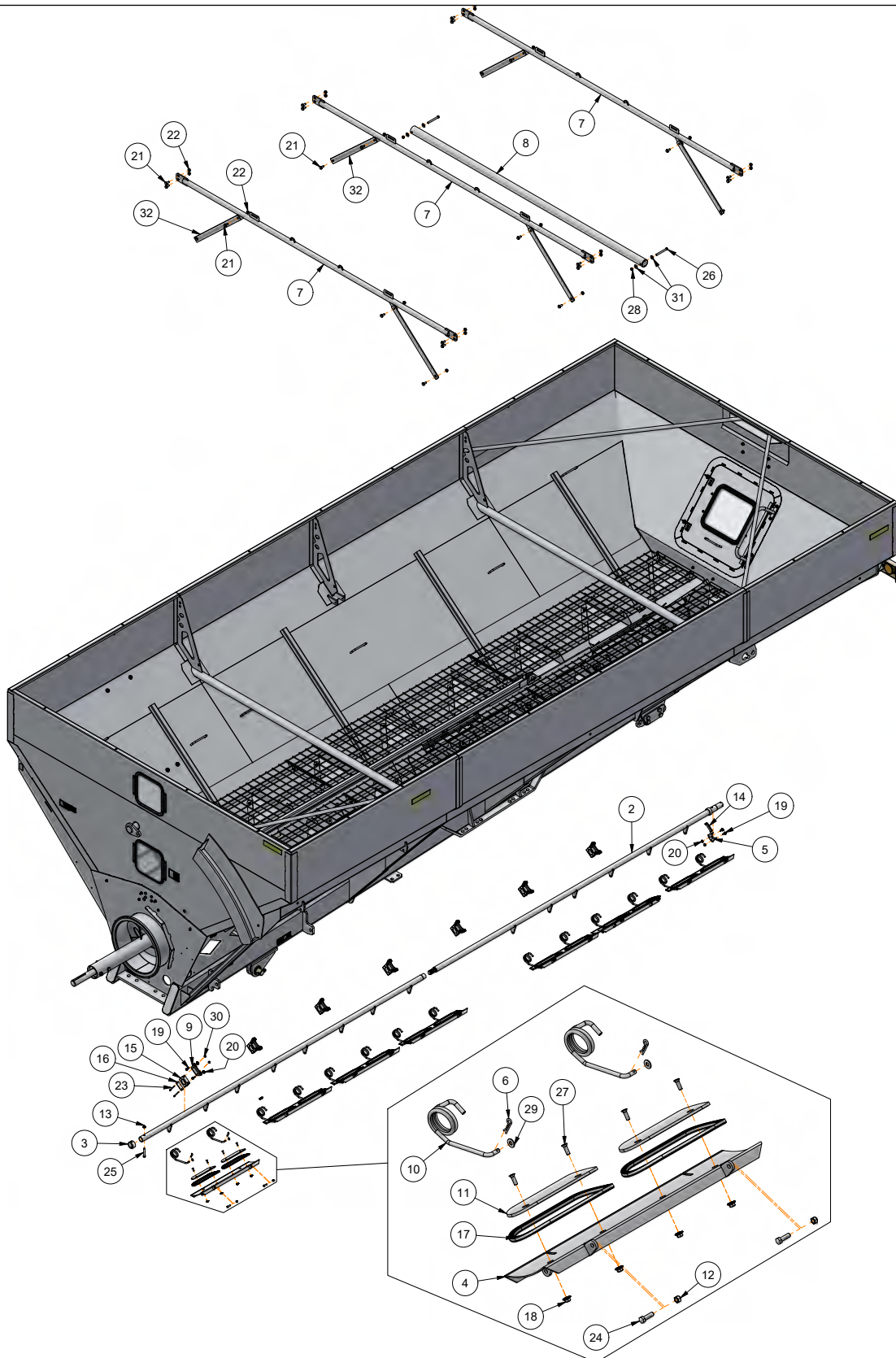

Hopper Cross Brace & Cleanout Door Components

Please visit www.unverferth.com/parts/ for the most current parts listing.

ITEM	PART NO.	DESCRIPTION	QTY	NOTES
1	271562B	Front Link Arm Weldment =Black=	1	
2	296813B	Rear Link Arm Weldment =Black=	1	
3	271566B	Stop Bushing =Black=	1	
4	271664B	Cleanout Door Weldment W/Holes =Black=	7	
5	273753B	Door Latch Weldment =Black=	1	
6	TA8B95	Hairpin Cotter, 1/8" Dia. x 1 15/16"	14	
7	296630B	Cross Tube Weldment =Black=	3	For SN B44630100 & Higher
	282416B		3	For SN B44630099 & Lower
8	296826B	Middle Cross Tube Weldment =Black=	1	For SN B44630100 & Higher For Tracks Only
	295875B		1	For SN B42310100 - B44630099 For Tracks Only
9	286414B	Door Pivot Bracket =Black=	7	
10	286417	Door Linkage Spring	14	
11	286418B	Cleanout Door Doubler Plate =Black=	14	
12	9928	Lock Nut/Top, 3/8"-16UNC Grade 5	14	
13	9003397	Locking Flange Nut, 1/2"-13UNC	1	
14	9005305	Lynch Pin, 3/8" Dia. x 3"	1	
15	9006351	Clamp	7	
16	9006352	Top Plate	7	
17	9007108	Rubber Gasket	14	
18	91257	Large Flange Hex Nut, 5/16"-18UNC Grade 5	28	
19	91262	Large Flange Screw, 3/8"-16UNC x 1" Grade 5	48	
20	91263	Large Flange Nut, 3/8"-16UNC Grade 5	48	
21	91266	Flange Screw, 1/2"-13UNC x 1 1/4" Grade 5	16	
22	9002058	Flange Nut, 1/2"-13UNC Grade 5	16	
23	9390-015	Capscrew, 1/4"-20UNC x 3 1/2" Grade 5	14	
24	9390-056	Capscrew, 3/8"-16UNC x 1 1/4" Grade 5	14	
25	9390-108	Capscrew, 1/2"-13UNC x 3 1/4" Grade 5	1	
26	9390-113	Capscrew, 1/2"-13UNC x 5" Grade 5	2	For SN B42310100 & Higher
27	903171-660	Flat Countersunk Head Machine Screw, 5/16"-18UNC x 1"	28	
28	9800	Locknut, 1/2"-13UNC Grade 5	2	For SN B42310100 & Higher
29	9405-070	Flat Washer, 5/16" USS	14	
30	97189	Large Flange Hex Nut, 1/4"-20UNC	15	
31	9405-088	Flat Washer, 1/2" USS	4	For SN B44630100 & Higher
32	296650B	Brace Bar =Black=	6	For SN B44630100 & Higher

Sideboards - For SN B43110100 & Higher

Please visit www.unverferth.com/parts/ for the most current parts listing.

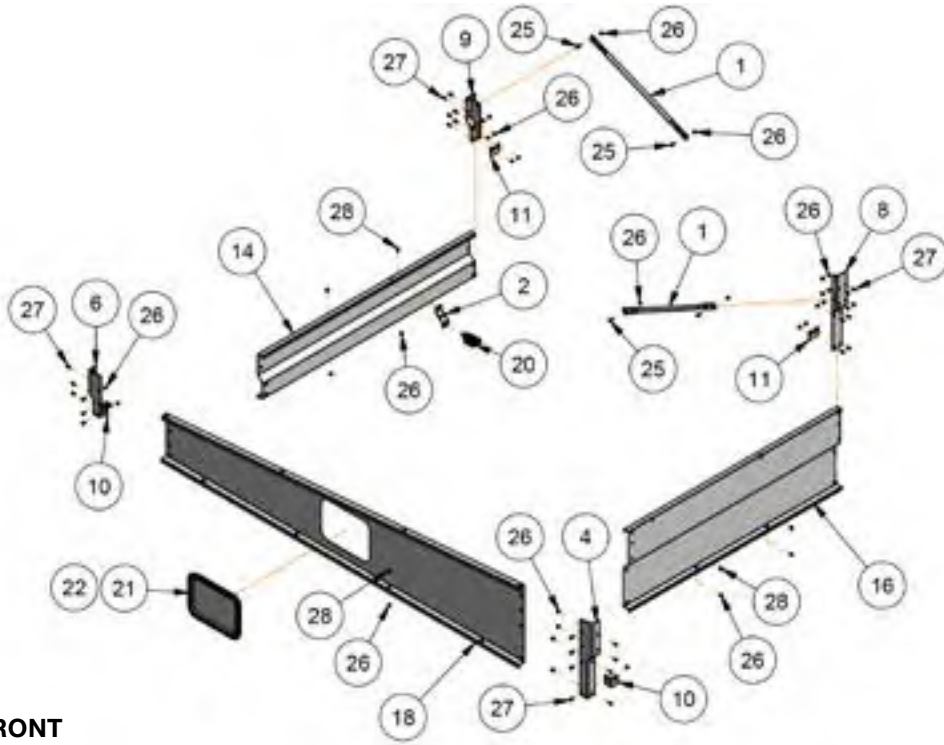

FRONT

REAR

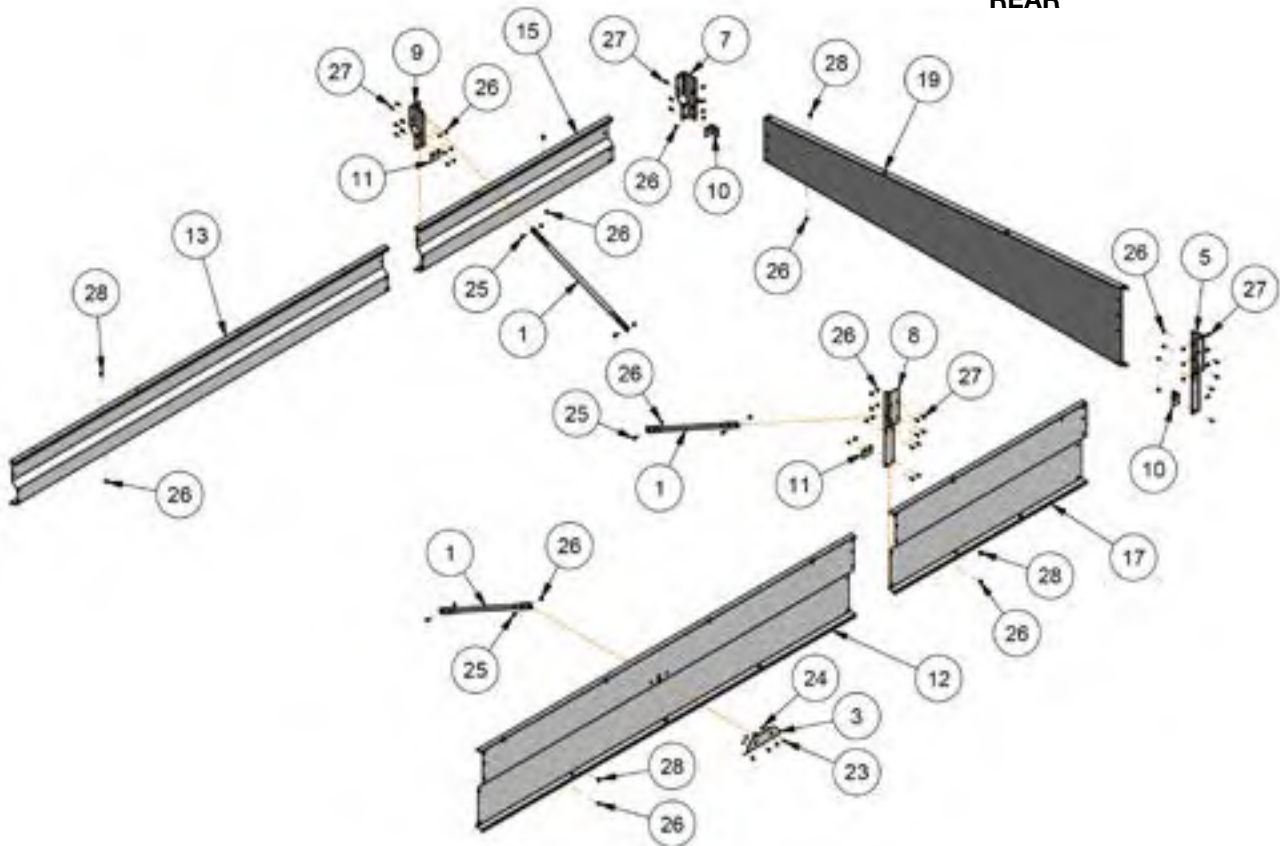

Sideboards - For SN B43110100 & Higher

Please visit www.unverferth.com/parts/ for the most current parts listing.

ITEM	PART NO.	DESCRIPTION	QTY	NOTES
1	220032B	Angle Brace Tube =Black=	5	
2	271574B	Lamp Mount Bracket =Black=	1	
3	282319B	Cross Brace Bracket Weldment =Black=	1	
4	295729B	LH Front Sideboard Corner Plate =Black=	1	
5	295730B	LH Rear Sideboard Corner Plate =Black=	1	
6	295731B	RH Front Sideboard Corner Plate =Black=	1	
7	295732B	RH Rear Sideboard Corner Plate =Black=	1	
8	295734B	LH Sideboard Bracket =Black=	2	
9	295733B	RH Sideboard Bracket =Black=	2	
10	295667B	Sideboard Cover Bracket =Black=	4	
11	295691B	Sideboard Cover Plate =Black=	4	
12	295727B	LH Center Sideboard Weldment =Black=	1	
13	295724B	RH Center Sideboard Weldment =Black=	1	
14	295723B	RH Front Sideboard Weldment =Black=	1	
15	295725B	RH Rear Sideboard Weldment =Black=	1	
16	295726B	LH Front Sideboard Weldment =Black=	1	
17	295728B	LH Rear Sideboard Weldment =Black=	1	
18	295948B	Front Board Replacement Kit (Black)	1	Includes Items 21 & 22
19	295879B	Rear Board =Black=	1	
20	9008957	LED Work Light	1	
21	92403	Window (Clear Tempered)	1	
22	250341	Window Moulding	1	
23	91256	Screw/Large Flange, 5/16"-18UNC x 3/4" G5	4	
24	91257	Hex Nut/Large Flange, 5/16"-18UNC G5	4	
25	91262	Screw/Large Flange, 3/8"-16UNC x 1	10	
26	91263	Hex Nut/Large Flange, 3/8"-16UNC G5	98	
27	9388-051	Carriage Bolt, 3/8"-16UNC x 1" G5	56	
28	95585	Capscrew/Large Flange, 3/8"-16UNC x 3/4" G5	22	

Sideboards - For SN B43110099 & Lower

Please visit www.unverferth.com/parts/ for the most current parts listing.

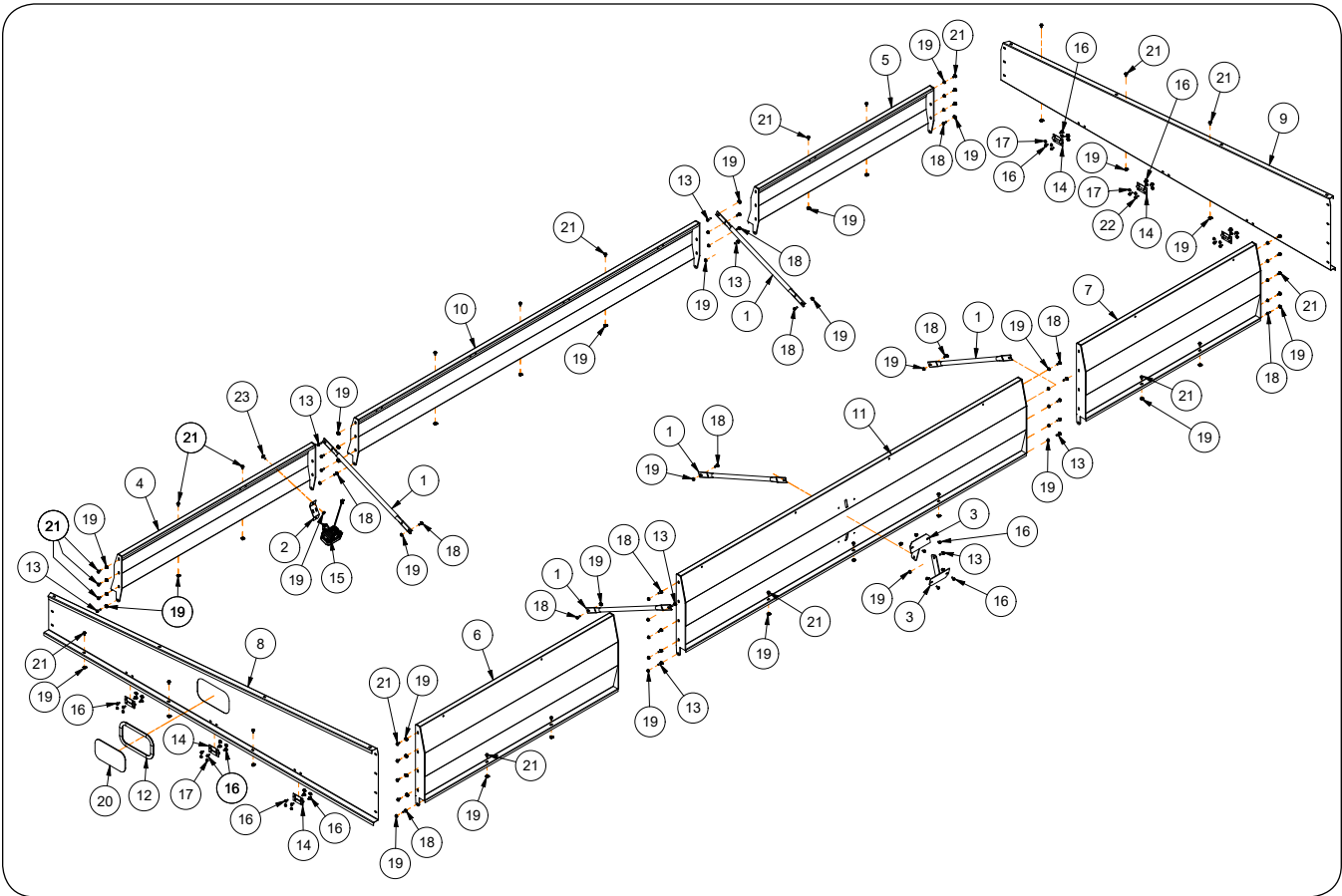

Sideboards - For SN B43110099 & Lower

Please visit www.unverferth.com/parts/ for the most current parts listing.

ITEM	PART NO.	DESCRIPTION	QTY	NOTES
1	220032B	Angle Brace Tube =Black=	5	
2	271574B	Lamp Mount Bracket =Black=	1	
3	282319B	Brace Weldment =Black=	2	
4	282554B	Board Weldment Front RH =Black=	1	
5	282555B	Board Weldment Rear RH =Black=	1	
6	282562B	Board Weldment Front LH =Black=	1	
7	282563B	Board Weldment Rear LH =Black=	1	
8	282547B	Board Front =Black=	1	
9	282548B	Board Rear =Black=	1	
10	282553B	Board Weldment Center RH =Black=	1	
11	282321B	Board Weldment Center LH =Black=	1	
12	250431	Window Moulding	1	
13	9003259	Flange Screw, 3/8"-16UNC x 1 1/4"	9	
14	9004626	Hinge	6	
15	9008957	Work Light LED	1	For SN B40450100 & Higher
	9007186			For SN B40450099 & Lower
16	91256	Screw/Large Flange, 5/16"-18UNC x 3/4" Grade 5	38	
17	91257	Hex Nut/Large Flange, 5/16"-18UNC Grade 5	46	
18	91262	Screw/Large Flange, 3/8"-16UNC x 1"	19	For SN B42320100 & Higher
			20	For SN B42320099 & Lower
19	91263	Hex Nut/Large Flange, 3/8"-16UNC Grade 5	69	
20	92403	Window (Clear Tempered)	1	
21	95585	Capscrew/Large Flange, 3/8"-16UNC x 3/4" Grade 5	35	
22	97604	Flange Screw, 5/16"-18UNC x 1"	2	
23	9009089	Torx Head Machine Screw 3/8-16UNC x 1 1/4 Grade 5	1	For SN B42320100 & Higher

Tandem Axle Components

Please visit www.unverferth.com/parts/ for the most current parts listing.

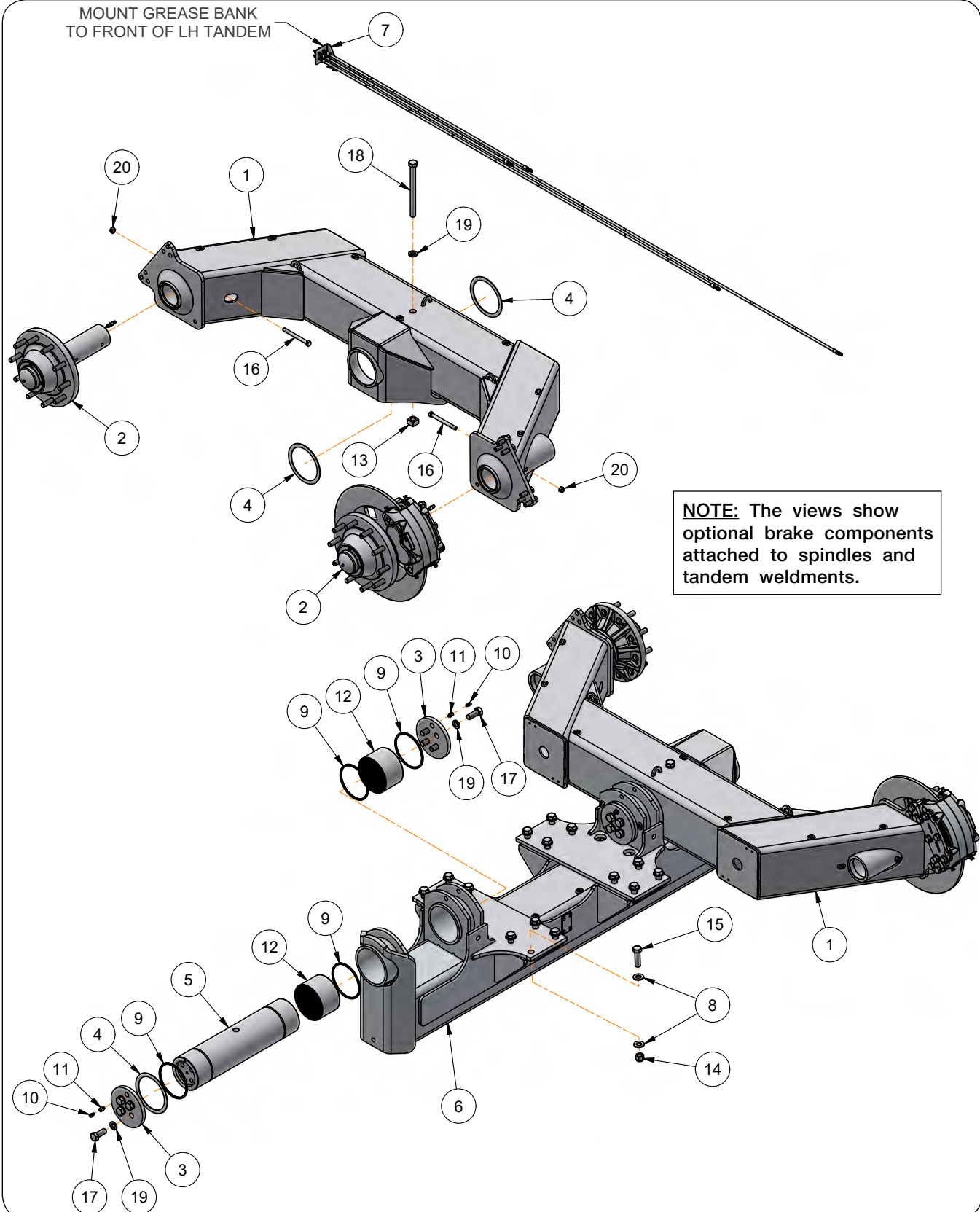

Tandem Axle Components

Please visit www.unverferth.com/parts/ for the most current parts listing.

ITEM	PART NO.	DESCRIPTION	QTY.	NOTES
1	288851B	Tandem Weldment =Black=	2	
2	283796B	Hub & Spindle Assembly With Scales (Black)	4	Refer to "Tandem Hub Components" for parts list
	286170B	Hub & Spindle Assembly Without Scales (Black)	4	
3	288542B	Cover Plate =Black=	4	
4	282690	Washer 8 1/2" OD x 7.063" ID	6	
5	293579	Pin Weldment	2	
6	293600B	Tandem Axle Weldment =Black=	1	
7	293620B	Grease Bank Assembly (Black)	1	
8	804685	Washer 2" OD	32	
9	9006410	Seal	8	
10	9006785	Adapter 90°, 1/8" NPT	4	
11	9006816	Adapter 1/8" NPT	4	
12	9006971	Pivot Bushing	4	
13	9007888	Heavy Square Nut 1"-8UNC Gr.5	2	
14	9008441	Elastic Locknut 1"-14UNS Gr.8	16	
15	91299-1458	Capscrew 1"-14UNS x 3 1/2" Gr.8	16	
16	9390-137	Capscrew 5/8"-11UNC x 6 1/2"	4	
17	9390-185	Capscrew 1"-8UNC x 2 1/2"	16	
18	9390-468	Capscrew 1"-8UNC x 12"	2	
19	9404-041	Lock Washer 1"	18	
20	95905	Lock Nut/Center 5/8"-11UNC	4	

Tandem Hub Components

Please visit www.unverferth.com/parts/ for the most current parts listing.

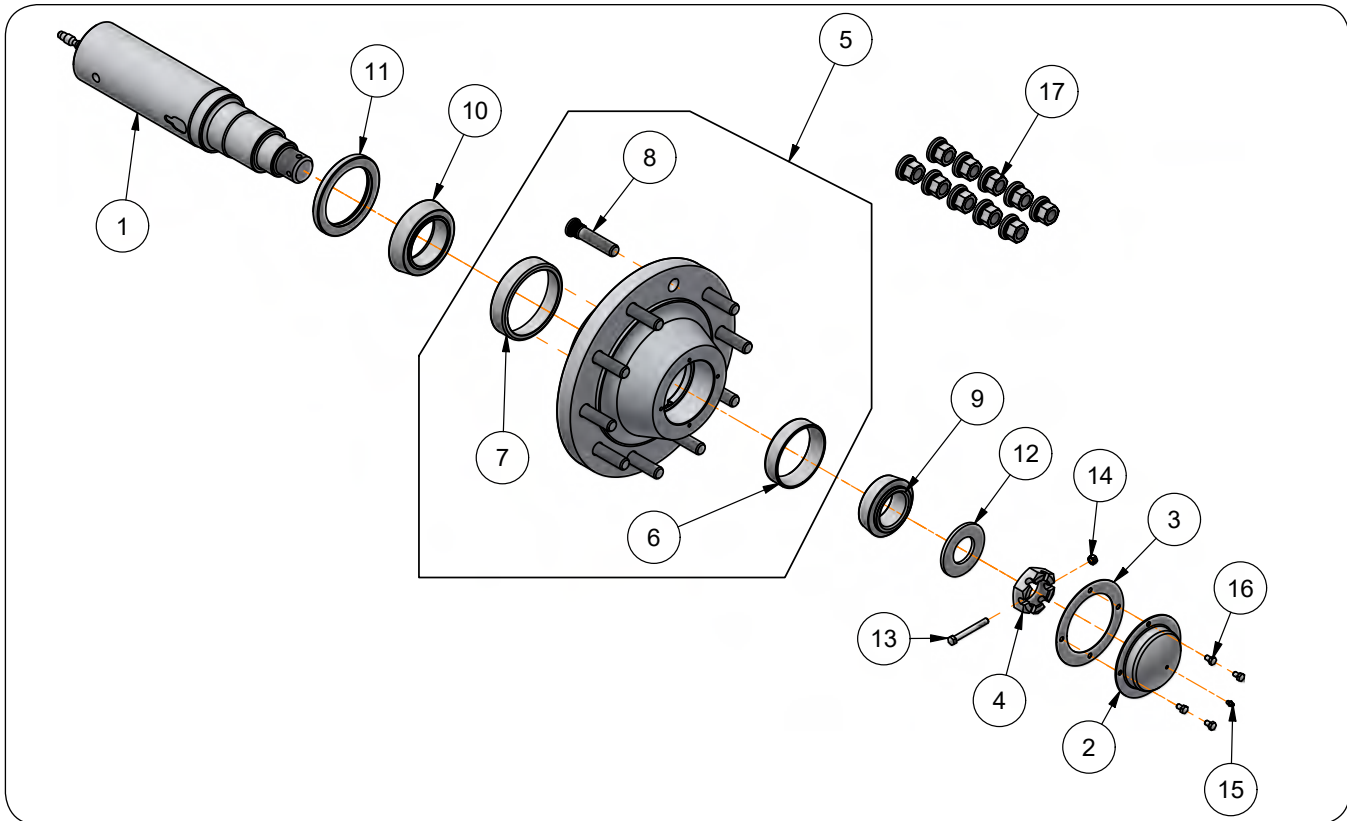

ITEM	PART NO.	DESCRIPTION	QTY	NOTES
	283796B	Hub & Spindle Assembly (Black) For Scales		Includes Items 1 through 16
	286170B	Hub & Spindle Assembly (Black) Without Scales		Includes Items 1 through 16
1	9006348	Scale Spindle 4 1/2" Dia.	1	For Scales
	286172	Spindle 4 1/2" Dia.	1	Without Scales
2	286171B	Hub Cap =Black=	1	
3	284230	Gasket	1	
4	92470	Castle Nut, 2"-12UNF Grade 5	1	
5	283739B	Hub Sub-Assembly =Black=	1	
6	92462	Bearing Cup 4.8125" Dia. (HM212011)	1	
7	92476	Bearing Cup 5.786" Dia. (HM218210)	1	
8	9007001	Stud Bolt, M22 x 1.5 x 4	10	
9	92464	Outer Bearing Cone 2.625" Bore (HM212049)	1	
10	92545	Inner Bearing Cone 3.5423" Bore (HM218248)	1	
11	92455	Grease Seal	1	
12	92472	Spindle Washer (Hardened)	1	
13	9390-064	Capscrew 3/8"-16UNC x 3 1/4" Grade 5	1	
14	902875	Locknut, 3/8"-16UNC	1	
15	91160	Grease Zerk	1	
17	9390-026	Capscrew, 5/16"-18UNC x 1/2" Grade 5	4	
	267275	Wheel Nut Kit	1	Use with Item 8
	97319	Flanged Cap Nut, M22 x 1.5	10	

Tandem Wheels & Tires

Please visit www.unverferth.com/parts/ for the most current parts listing.

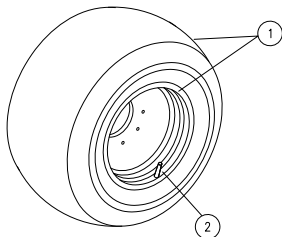

TIRES

For questions regarding new tire warranty, please contact your local original equipment tire dealer. Used tires carry no warranty. Tire manufacturers' phone numbers and websites are listed in the Maintenance Section for your convenience.

ITEM	PART NO.	DESCRIPTION	QTY	NOTES
1	18325SM	Wheel & Tire Assembly	4	30 x 32 / 900/60R32 R1W (Silver Mist)
	17939SM	Wheel Only	4	30 x 32 (Silver Mist)
	99498	Tire Only	4	TL900/60R32 R-1W (181A8)
2	93300	Valve Stem	4	
	95365	Plug	4	

Tandem Grease Bank Assembly #293620B

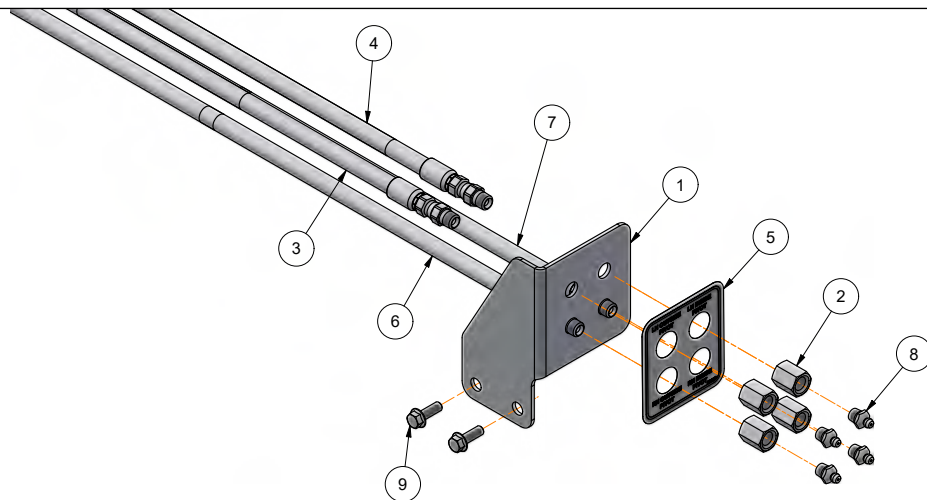

ITEM	PART NO.	DESCRIPTION	QTY.	NOTES
1	293621B	Grease Bank Bracket =Black=	1	
2	9003949	Coupler 1/8" NPT	4	
3	9008248	Hose 3/16" x 57"	1	
4	9008182	Hose 3/16" x 53"	1	
5	9008499	Decal, Grease Bank	1	
6	9008707	Hose 3/16" x 141"	1	
7	9008708	Hose 3/16" x 120"	1	
8	93426	Grease Zerk	4	
9	97420	Flange Screw 1/4"-20UNC x 3/4"	2	

Brake Components (Optional)

(Requires tractor with Implement Braking)

Please visit www.unverferth.com/parts/ for the most current parts listing.

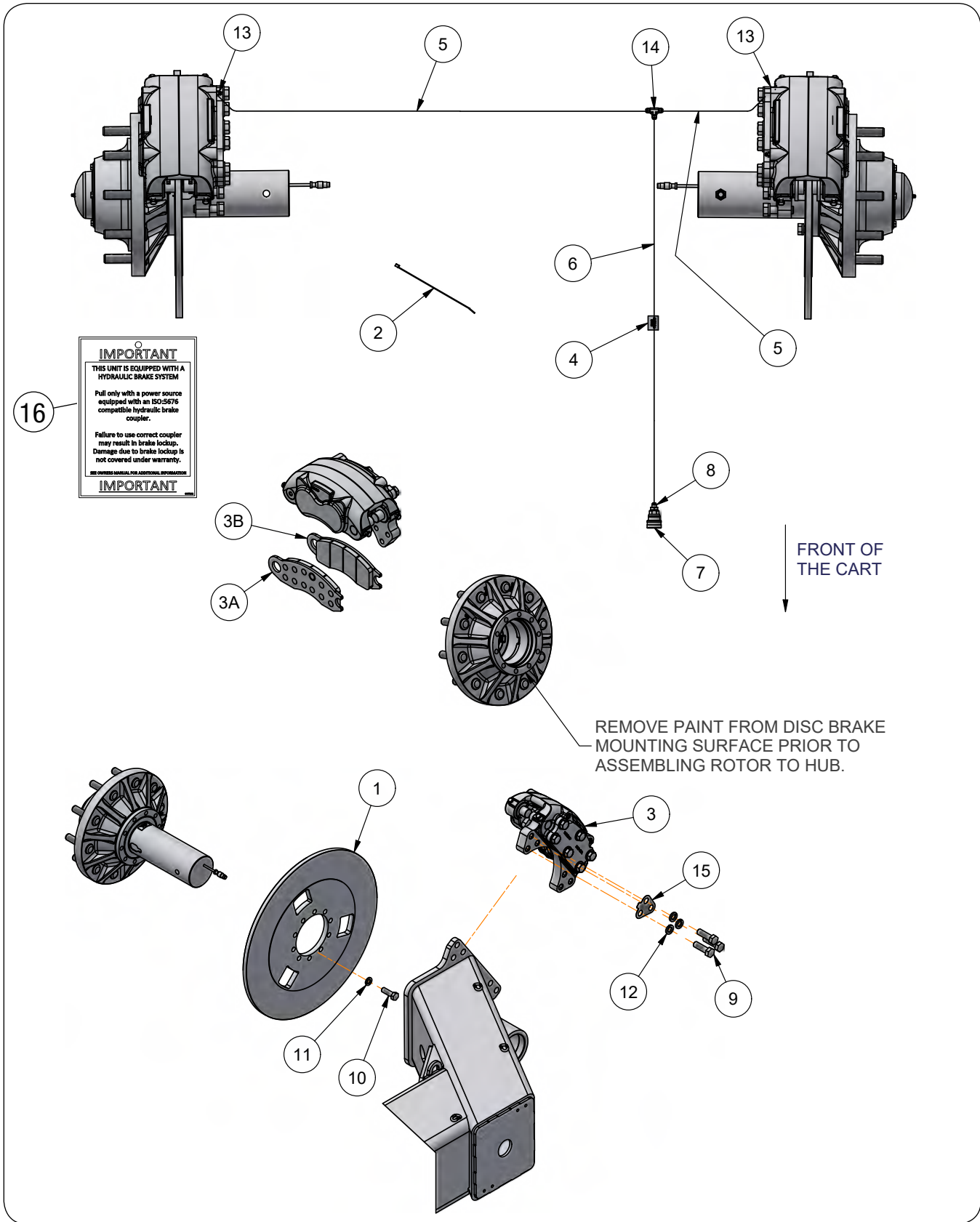

Brake Components (Optional)

(Requires tractor with Implement Braking)

Please visit www.unverferth.com/parts/ for the most current parts listing.

ITEM	PART NO.	DESCRIPTION	QTY	NOTES
1	283711	Brake Rotor Plate	2	
2	9003735	Cable Tie, 11" Long	24	
3	9004762	Brake Assembly	2	
3A	9007135	Brake Pad - Outer	1	Quantity Per Brake Caliper (Not Shown)
3B	9007136	Brake Pad - Inner	1	
3C	9007137	Seal Kit	1	
4	9004829	Hose Marker Sleeve (Blue) = Brake Pressure	1	
5	9004885	Hose, 1/4" x 108" (3000 PSI)	2	
6	9004886	Hose, 1/4" x 390" (3000 PSI)	1	
7	9005173	Quick Coupler	1	
8	9006005	Adapter, 9/16"-18 JIC M x 18x1.5 M	1	
9	9390-147	Capscrew, 3/4"-10UNC x 2 1/2" Grade 5	12	
10	9390-348	Capscrew, 5/8"-18UNF x 2" Grade 5	20	
11	9404-029	Lock Washer, 5/8"	20	
12	9404-033	Lock Washer, 3/4"	12	
13	97711	Adapter, 9/16"-18 JIC M x 7/16"-20 O-R M	2	Locate/Replace in lowest bleeder port of each caliper.
14	9875	Tee, 9/16"-18 JIC M	1	
15	286237	Shim	16	Use as Needed
16	9007162	Brakes Information Tag	1	

Track Axle Components

Please visit www.unverferth.com/parts/ for the most current parts listing.

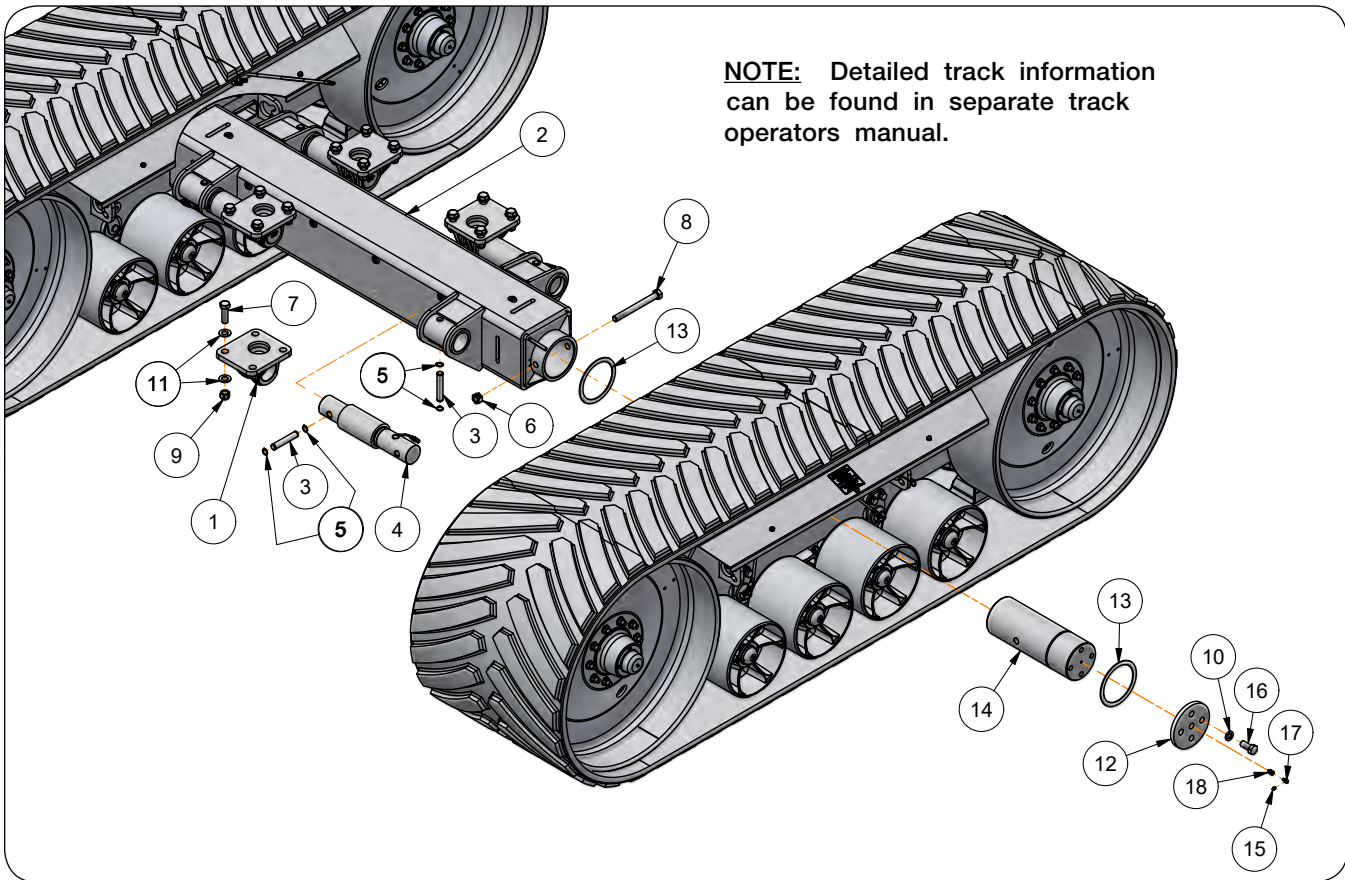

ITEM	PART NO.	DESCRIPTION	QTY	NOTES
1	268838B	Axle Mount =Black=	4	
2	282035B	Axle Weldment =Black=	1	42" Equalizer Tracks
	282744B	Axle Weldment =Black=	1	Standard Tracks, 50" Equalizer Tracks & Optional Long Axle for 42" Equalizer Tracks
3	282876	Hitch Pin, 1" Dia. x 5 1/2"	8	
4	9005811	Scale Bar, 3.50" (SHOWN)	4	
	282745	Bar, 3.50" - Non-Scale	4	
5	91192	Retaining Ring 1"	16	
6	92199	Locknut, 1"-8UNC	2	
7	91299-1457	Capscrew 1"-14UNS x 3 1/4" Grade 8	16	
8	9390-464	Capscrew 1"-8UNC x 10" Grade 5	2	
9	9008441	Elastic Lock Nut 1"-14UNS Grade 8	16	
10	9404-041	Lock Washer, 1"	8	
11	804685	Washer, 1 1/16" ID	32	
	282689B	Cover Plate =Black=	2	
13	282690	Washer 8 1/2" OD	4	
14	282102	Track Pivot Shaft, 7" Dia. x 19 1/8"	2	Equalizer Tracks
	282742	Track Pivot Shaft 7" Dia. x 19 3/16"	2	Standard Tracks
15	93426	Grease Zerk	2	Standard Tracks
16	9390-184	Capscrew 1"-8UNC x 2 1/4" Grade 5	8	
17	9006785	90° Adapter 1/8" NPT	1	Equalizer Tracks
18	9006816	Adapter 1/8" NPT	1	Equalizer Tracks

Track Panel Kit Components

Please visit www.unverferth.com/parts/ for the most current parts listing.

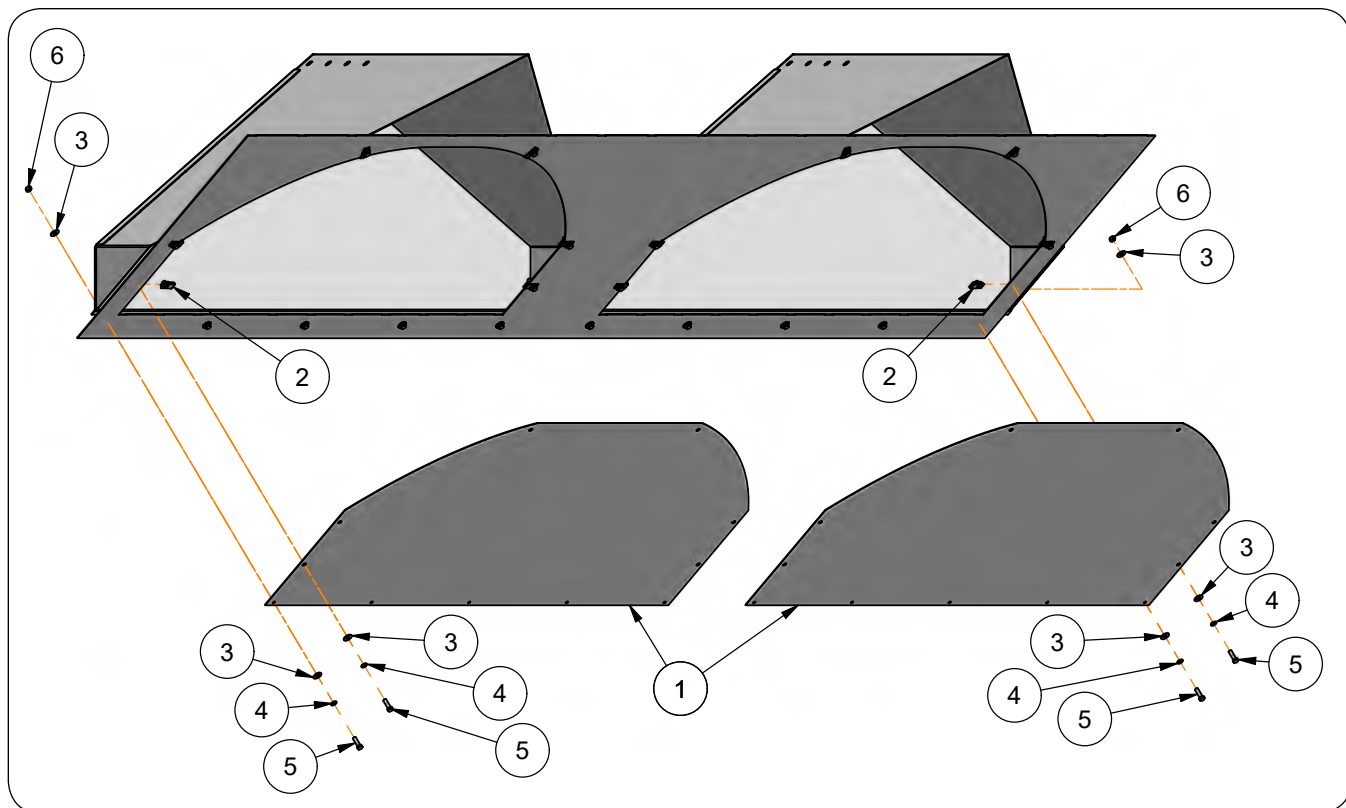

ITEM	PART NO.	DESCRIPTION	QTY	NOTES
	284213G	Track Panel Kit =Green=	-	Includes Items 1 through 6
	284213R	Track Panel Kit =Red=		
1	284212G	Track Panel Plate =Green=	4	
	284212R	Track Panel Plate =Red=		
2	9005376	U-nut, 3/8"-16UNC	24	
3	9405-076	Flat Washer, 3/8" USS	64	
4	9404-021	Lock Washer, 3/8"	44	
5	9390-056	Capscrew, 3/8"-16UNC x 1 1/4" G5	44	
6	9394-006	Hex Nut, 3/8"-16UNC	20	

Hopper Flow Door Components

Please visit www.unverferth.com/parts/ for the most current parts listing.

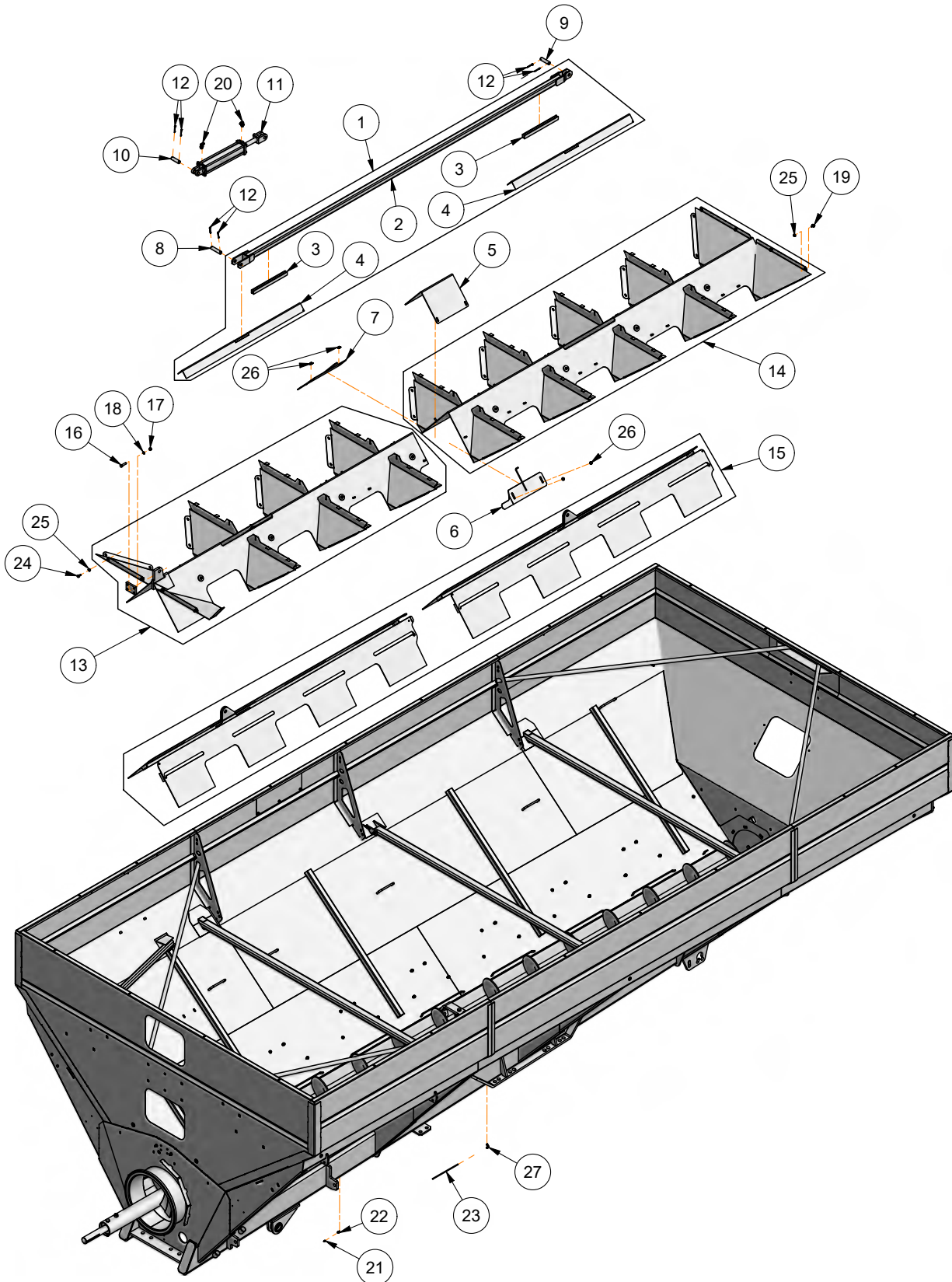

Hopper Flow Door Components

Please visit www.unverferth.com/parts/ for the most current parts listing.

ITEM	PART NO.	DESCRIPTION	QTY	NOTES
1	294156B	Flow Door Linkage Replacement Kit (Black)	1	For SN B40450100 & Higher Includes Items 2 - 4
	255186B			For SN B40450099 & Lower
2	294154B	Flow Door Linkage Weldment =Black=	1	
3	271331*	Seal Plate	4	*Not for individual sale, see Item 1
4	282187B	Tent Hole Cover Plate =Black=	2	
5	282488B	Cover Plate =Black=	1	
6	284723B	Center Door Weldment Left-Hand =Black=	1	
7	284724B	Center Door Weldment Right-Hand =Black=	1	
8	266285	Idler Pin 1" Dia. x 4 1/2"	1	
9	271112	Idler Pin 1" Dia. x 4"	1	
10	804572	Hydraulic Cylinder Pin 1" Dia. x 3 1/2"	1	
11	9002575	Hydraulic Cylinder 3" x 16"	1	
12	9391-046	Cotter Pin 3/16" Dia. x 2"	6	
13	294072B	Front Tent Service Kit (Black)	1	For SN B41030100 & Higher Refer to "Front and Rear Flow Door Components" for parts list.
	284825B			For SN B41030099 & Lower Refer to "Front and Rear Flow Door Components" for parts list.
14	294073B	Rear Tent Service Kit (Black)	1	For SN B41030100 & Higher Refer to "Front and Rear Flow Door Components" for parts list.
	284826B			For SN B41030099 & Lower Refer to "Front and Rear Flow Door Components" for parts list.
15	284889B	Flow Door Service Kit (Black)	1	
16	9390-103	Capscrew 1/2"-13UNC x 2" Grade 5	4	
17	9394-010	Hex Nut 1/2"-13UNC Grade 5	4	
18	9404-025	Lock Washer 1/2"	4	
19	95585	Capscrew/Lrg. Flange 3/8"-16UNC x 3/4" Gr.5	68	
20	9874	90° Elbow 9/16"-18 JIC Male x 3/4"-16 O-Ring Adj Male Boss	2	
21	93426	Grease Zerk	1	
22	9005073	Quicklinc Fitting 1/4" Tube x 1/8" NPT Straight	1	For SN B40450100 & Higher
	9005072	Quicklinc Fitting 1/4" Tube x 1/8" NPT Elbow	1	For SN B40450099 & Lower
23	9005074	Grease Hose 1/4" OD	3	Specify In Feet
24	91262	Flange Screw, 3/8"-16UNC x 1" Grade 5	4	
25	9008159	Automation Lock Nut/Top 3/8"-16UNC Gr.F	72	
26	91263	Nut/Large Flange 3/8"-16UNC Grade 5	4	
27	9005072	Quicklinc Fitting 1/4" Tube x 1/8" NPT Elbow	1	

Front and Rear Flow Door Components

Please visit www.unverferth.com/parts/ for the most current parts listing.

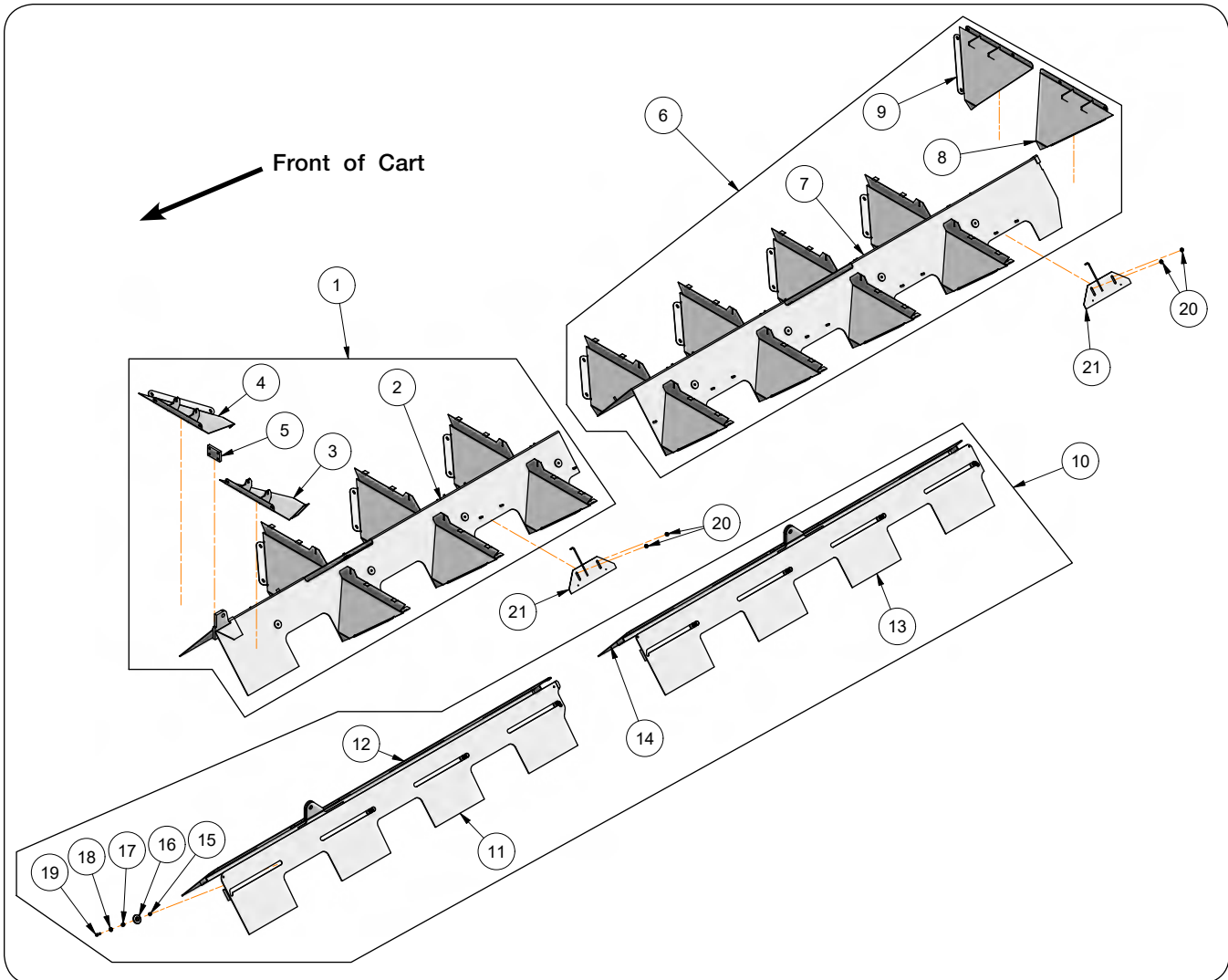

Front and Rear Flow Door Components

Please visit www.unverferth.com/parts/ for the most current parts listing.

ITEM	PART NO.	DESCRIPTION	QTY	NOTES	
1	294072B	Front Tent Service Kit (Black)	1	For SN B41030100 & Higher Includes Items 2-5	
	284825B			For SN B41030099 & Lower	
	2	294070B	Front Tent Weldment =Black=	1	
	3	283135B	Front LH Baffle =Black=	1	
	4	283136B	Front RH Baffle =Black=	1	
5	271054*	Cylinder Mount Plate	-	*Not for individual sale, see Item 1	
6	294073B	Rear Tent Service Kit (Black)	1	For SN B41030100 & Higher Includes Items 7-9	
	284826B			For SN B41030099 & Lower	
	7	294071B	Rear Tent Weldment =Black=	1	
	8	282139B	Rear LH Baffle =Black=	1	
9	282138B	Rear RH Baffle =Black=	1		
10	284889B	Flow Door Service Kit (Black)	1	Includes Items 11-19	
11	284855B	Front Door Weldment Left-Hand =Black=	1		
12	284854B	Front Door Weldment Right-Hand =Black=	1		
13	284850B	Rear Door Weldment Left-Hand =Black=	1		
14	284849B	Rear Door Weldment Right-Hand =Black=	1		
15	9003396	Locknut 3/8"-16UNC	16		
16	284168	Spacer Bushing, 2 1/4" OD x 1/2"	16		
17	284169	Roller Bushing, 1/4" OD x 7/16" ID	16		
18	9005471	Flat Washer, 3/8"	16		
19	91299-057	Capscrew, 3/8"-16UNC x 1 1/2"	16		
20	91263	Locknut, 3/8"-16UNC Gr.5	20		
21	284721B	Baffle Weldment =Black=	10		

Flow Door Indicator Assembly

Please visit www.unverferth.com/parts/ for the most current parts listing.

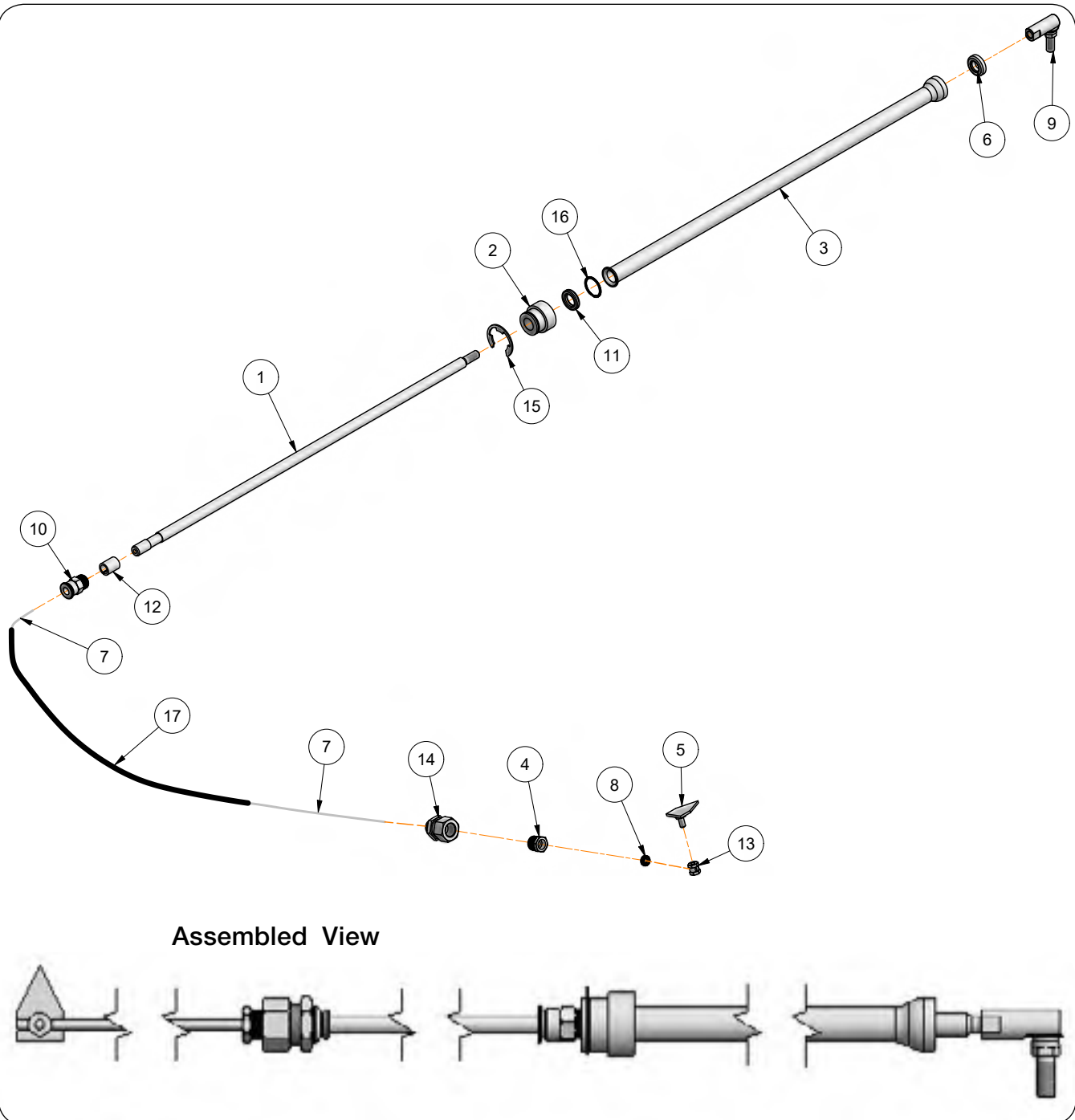

Flow Door Indicator Assembly

Please visit www.unverferth.com/parts/ for the most current parts listing.

ITEM	PART NO.	DESCRIPTION	QTY	NOTES
	271584	Complete Indicator Assembly	1	Includes Items 1 through 17
1	271582	Push Rod Indicator	1	
2	271585	Bushing - Coupler	1	
3	271589	Cable Tube (Push Rod)	1	
4	271593	Reducer Bushing	1	
5	271595R	Flow Door Indicator =Red=	1	
6	9006610	Seal (Wiper)	1	
7	9006611	Inner Cable (Conduit) - 3/16"	1	
8	9008612	Seal (Shaft)	1	
9	9006630	Rod End, 3/8"	1	
10	9006634	Connector Fitting	1	
11	9006635	Quad Ring	1	
12	9006636	Wear Ring	1	
13	271597	Wire Stop	1	
14	9006640	Hose Fitting	1	
15	9006641	Snap Ring	1	
16	9006644	Retaining Ring - Internal	1	
17	271586	Plastic Tubing - 81"	1	

Rear Runner Brace Components

Please visit www.unverferth.com/parts/ for the most current parts listing.

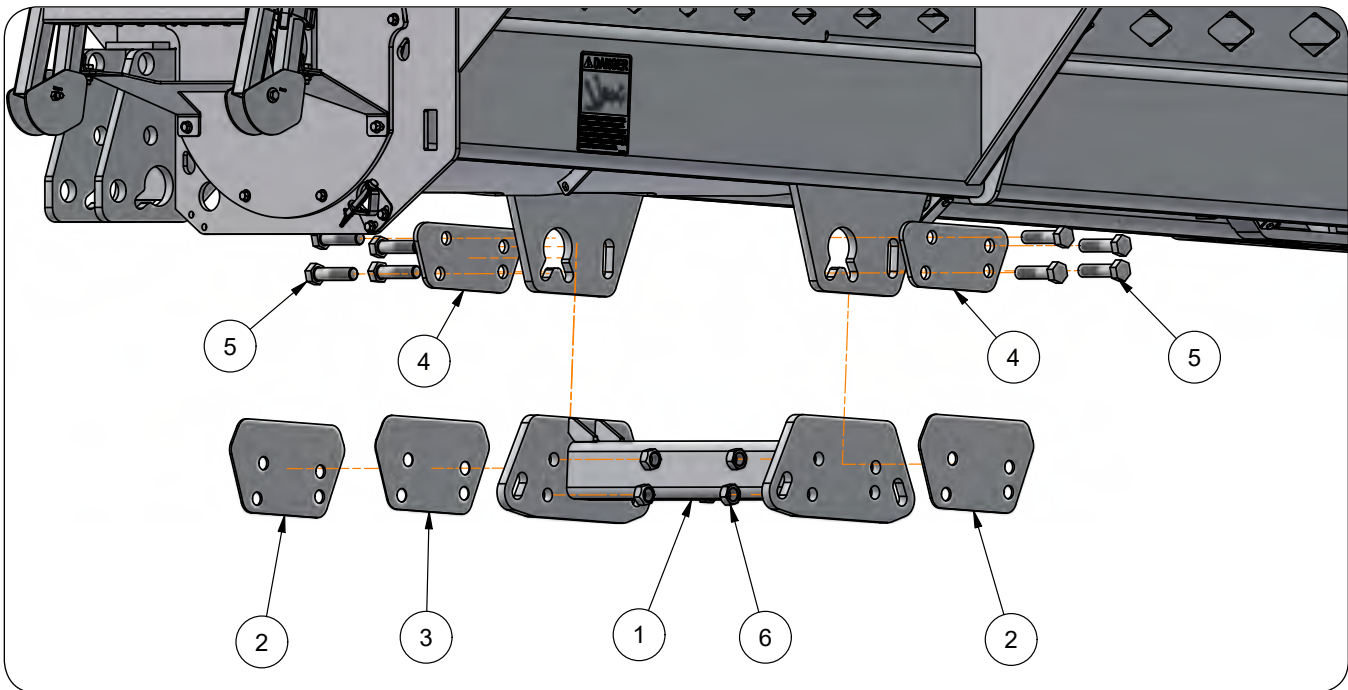

ITEM	PART NO.	DESCRIPTION	QTY	NOTES
1	297398G	Rear Runner Brace Weldment =Green=	1	For SN B44630100 & Higher
	297398R	Rear Runner Brace Weldment =Red=		
	297383G	Rear Runner Brace Weldment =Green=		For SN B43680100 - B44630099
	297383R	Rear Runner Brace Weldment =Red=		
	272814G	Rear Runner Brace Weldment =Green=		
	272814R	Rear Runner Brace Weldment =Red=		
2	297386G	Shim Plate, 8GA =Green=	2	For SN B43680100 & Higher
	297386R	Shim Plate, 8GA =Red=		
	272740G	Shim Plate, 8GA =Green=		For SN B43680099 & Lower
	272740R	Shim Plate, 8GA =Red=		
3	297387G	Shim Plate, 14GA =Green=	1	For SN B43680100 & Higher
	297387R	Shim Plate, 14GA =Red=		
	272741G	Shim Plate, 14GA =Green=		For SN B43680099 & Lower
	272741R	Shim Plate, 14GA =Red=		
4	272745G	Outer Cap Bolt Plate, 3/8" =Green=	2	
	272745R	Outer Cap Bolt Plate, 3/8" =Red=		
5	9390-170	Capscrew, 7/8"-9UNC x 3 1/2" Gr.5	8	For SN B44630100 & Higher
	9404-037	Lock Washer 7/8"	4	For SN B43680100 - B44630099
6	98420	Locknut, 7/8"-9UNC Gr.8	4	
6			8	

Notes

Please visit www.unverferth.com/parts/ for the most current parts listing.

Vertical Auger Flighting Components

Please visit www.unverferth.com/parts/ for the most current parts listing.

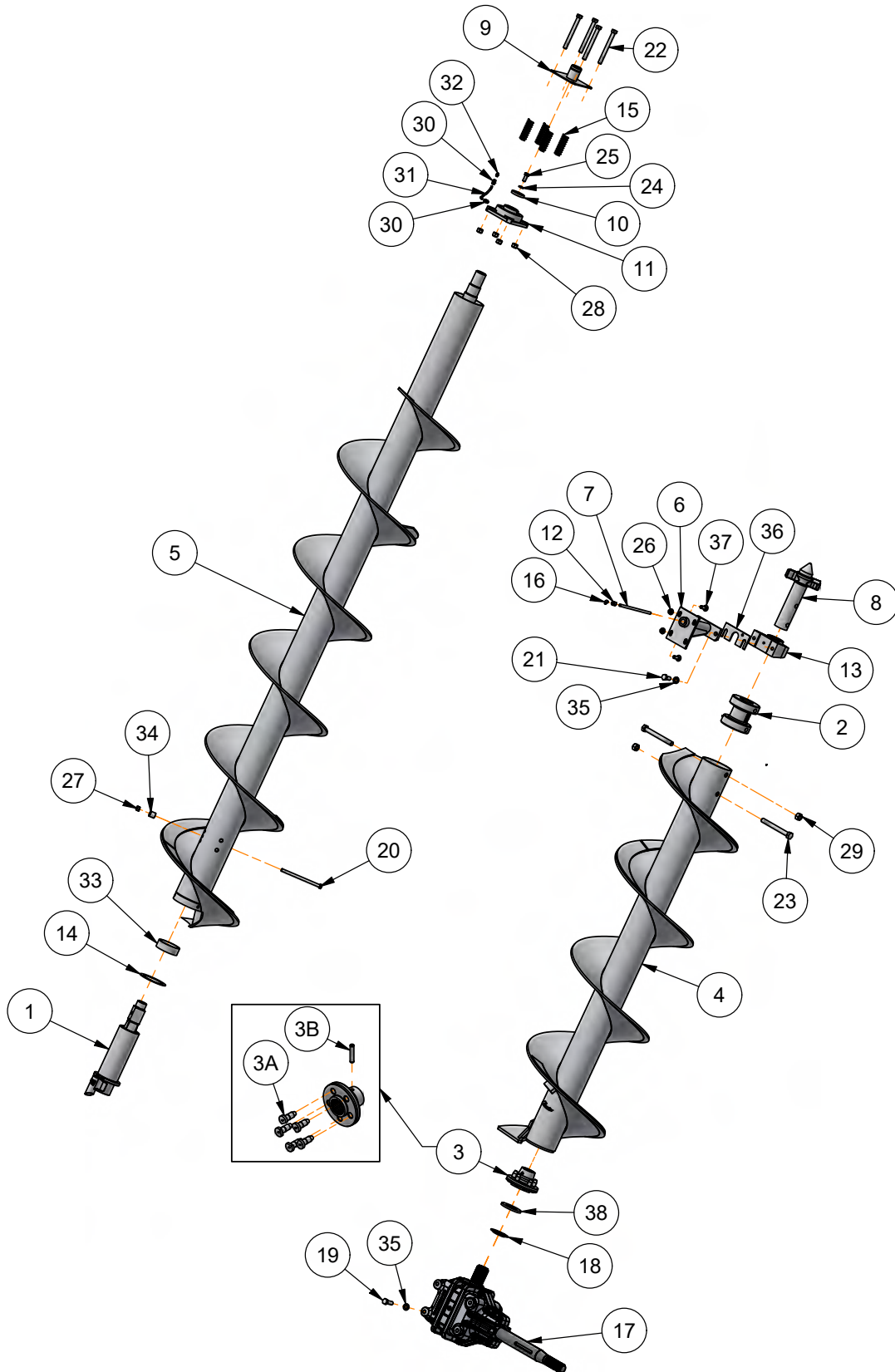

Vertical Auger Fighting Components

Please visit www.unverferth.com/parts/ for the most current parts listing.

ITEM	PART NO.	DESCRIPTION	QTY	NOTES
1	281283	Soft Start Assembly	1	
2	283515	Auger Tube Adapter	1	
3	287802	Auger Drive Plate Assembly - 5 Pin	1	Includes Items 3A & 3B
	3A 9007000	Drive Head Pin	5	
	3B 902614-238	Spiral Pin, 1/2" Dia. x 2 3/4"	1	
4	294131B	Lower Auger Replacement Kit (Black)	1	Includes Items 2 and 3
5	296588B	Upper Auger Replacement Kit (Black)	1	Includes Upper Auger Weldment, Items 10, 24 and 25
6	293420B	Bearing Bracket Weldment =Black=	1	
7	284636	Grease Pipe	1	
8	288813	Drive Dog, Machined	1	
9	284986	Hood Pivot Pin Weldment	1	
10	407699	Washer Plate, 2 1/2" Dia.	1	
11	9002492	Bearing 2" Dia. Flanged	1	
12	9003949	Pipe Coupling, 1/8" NPT Female	2	
13	9004731	Pillow Block Bearing, 2 1/2" Bore	1	
14	9004878	Self Lubricating Washer	1	
15	9004899	Spring - 10 Coils	4	
16	9000875	Grease Zerk	1	
17	9007366	Gearbox Assembly, 800 Series	1	
18	9007377B	Dust Cover =Black=	1	
19	9390-124	Capscrew, 5/8"-11UNC x 2" Grade 5	8	
20	9390-119	Capscrew, 1/2"-13UNC x 8" Grade 5	1	
21	9390-122	Capscrew, 5/8"-11UNC x 1 1/2" Grade 5	12	
22	9390-137	Capscrew, 5/8"-11UNC x 6 1/2" Grade 5	4	
23	9390-159	Capscrew, 3/4"-10UNC x 7" Grade 5	2	
24	9404-025	Lock Washer, 1/2" Grade 5	6	
25	9390-100	Capscrew, 1/2"-13UNC x 1 1/4" Grade 5	5	
26	9003397	Flange Locknut, 1/2"-13UNC	4	
27	9800	Locknut, 1/2"-13UNC Grade 5	1	
28	9801	Locknut, 5/8"-11UNC Grade 5	4	
29	9802	Locknut, 3/4"-10UNC Grade 5	2	
30	9005073	Quicklinc Fitting 1/4" Tube x 1/8" NPT	2	
31	9005074	Grease Hose 1/4" OD	1	
32	93426	Grease Zerk	1	
33	9004877	Self Lubricating Bushing 4.252"OD x 4.011"ID	1	
34	410511	Spacer Bushing	1	
35	9404-030	Lock Washer, 5/8" Extra	8	
36	286419B	Bearing Shim Plate =Black=	1	
37	9388-104	Carriage Bolt, 1/2"-13UNC x 1 1/2" Grade 5	4	
38	297008	Gearbox Output Shaft Washer	1	Replacement Kit #297010 For SN B44630100 & Higher Replacement Kit #297394 For SN B43680100 - B44630099

Horizontal Auger Components - SN B40450100 and Higher

Please visit www.unverferth.com/parts/ for the most current parts listing.

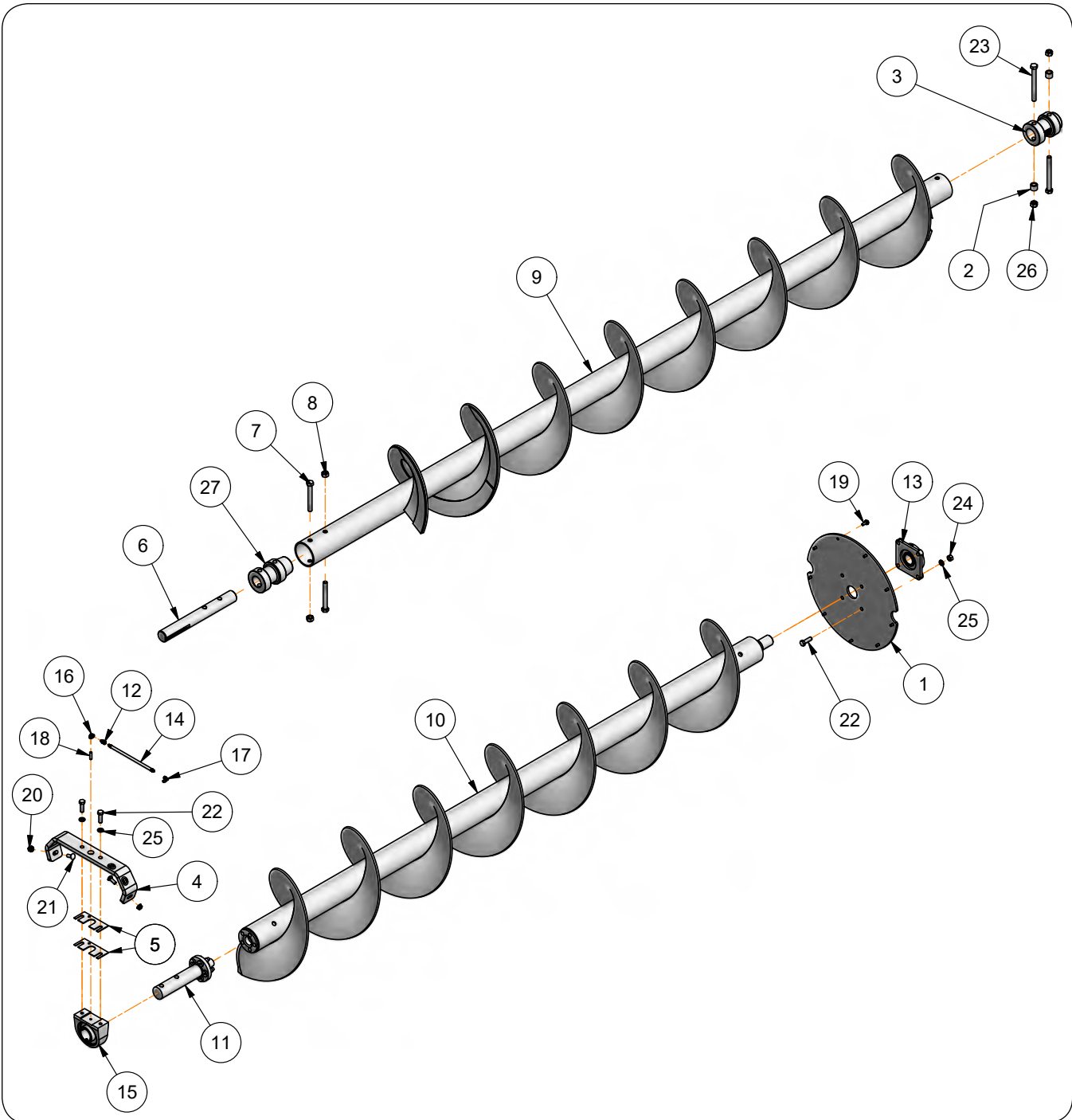

Horizontal Auger Components - SN B40450100 and Higher

Please visit www.unverferth.com/parts/ for the most current parts listing.

ITEM	PART NO.	DESCRIPTION	QTY	NOTES
1	283097G	Cover Plate =Green=	1	
	283097R	Cover Plate =Red=		
2	283895	Spacer Bushing, 1 1/4" OD x 0.813" ID x 1 1/8"	2	
3	286282	Adapter/Shaft Bushing Weldment =Primed=	1	
4	286381B	Bearing Mounting Bar =Black=	1	
5	286424B	Bearing Shim Plate =Black=	2	
6	283537	Auger Shaft 2.25" Dia.	1	
7	91299-157	Capscrew, 3/4"-10UNC x 6" Grade 8	2	
8	9802	Lock Nut, 3/4"-10UNC	2	
9	294138B	Front Auger Replacement Kit (Black)	1	Includes Items 3, 6 - 8, 27
10	293954B	Rear Auger Weldment =Black=	1	
11	293957	Auger Coupler Shaft Weldment	1	
12	9002479	Adapter 1/8"-27 NPTF Male x 1/8"-27 NPSM Female Swivel Nut	1	
13	9002492	Bearing/Flanged 2" Dia.	1	
14	9002689	Hose 1/8" x 12", 3000 PSI	1	
15	9004731	Pillow Block Bearing with 2 1/2" Bore	1	
16	9004764	90° Elbow 1/8" Female NPTF x 1/8" Female NPTF	1	
17	9005072	90° Elbow 1/4" Tube x 1/8"-27 NPTF Swivel Nut	1	
18	9006964	Nipple 1/8" NPT Male x 1/8" NPT Male	1	
19	91262	Capscrew, 3/8"-16UNC x 1" G5	21	
20	91267	Lock Nut, 1/2"-13UNC	2	
21	9388-104	Carriage Bolt, 1/2"-13UNC x 1 1/2" G5	2	
22	9390-124	Capscrew, 5/8"-11UNC x 2" G5	4	
23	9390-160	Capscrew, 3/4"-10UNC x 7 1/2" G5	2	
24	9394-014	Hex Nut, 5/8"-11UNC Grade 5	4	
25	9404-029	Lock Washer, 5/8"	6	
26	9802	Lock Nut, 3/4"-10UNC	2	
27	283535	Auger Tube Adapter	1	

Horizontal Auger Components - SN B40450099 and Lower

Please visit www.unverferth.com/parts/ for the most current parts listing.

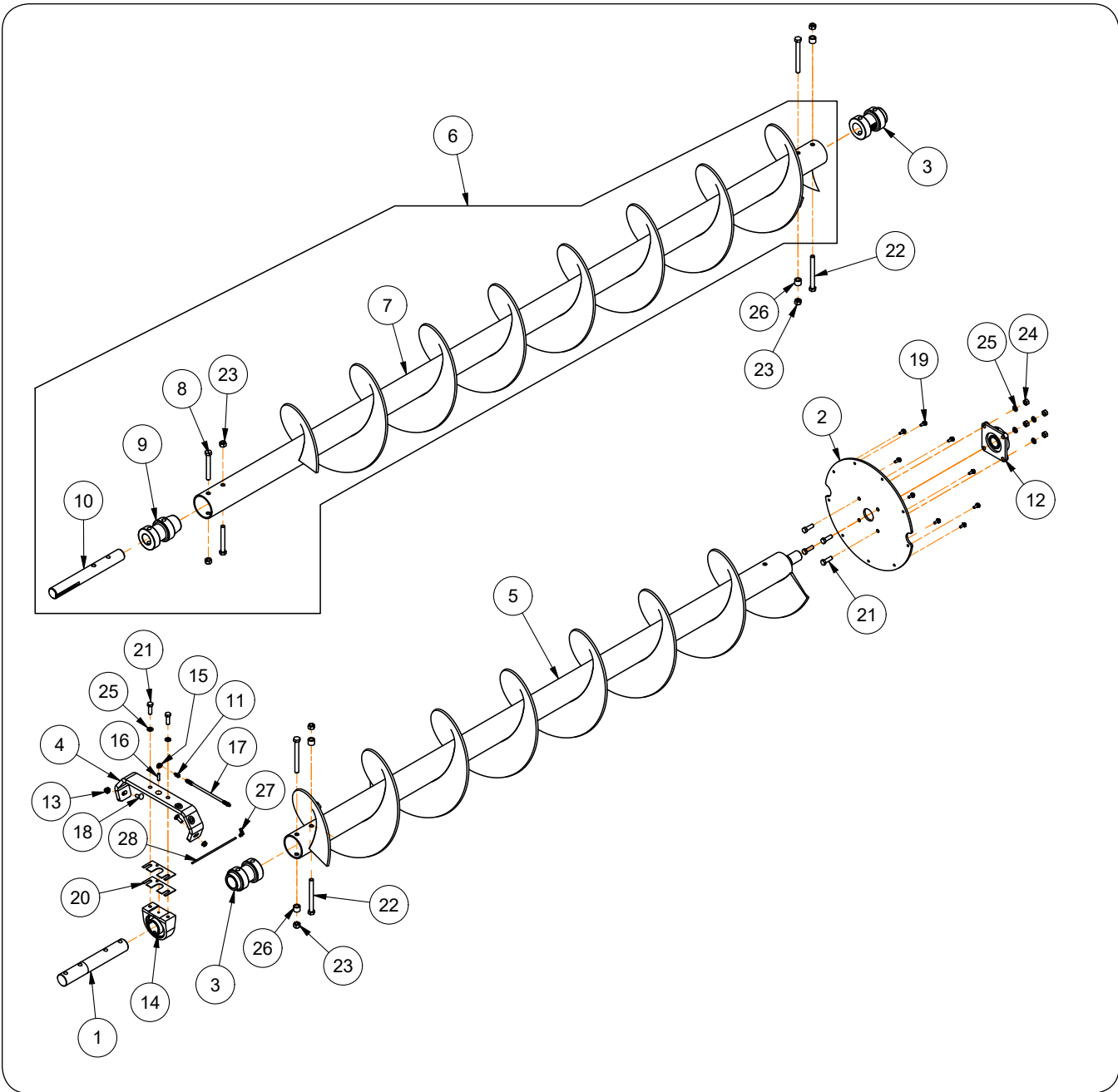

Horizontal Auger Components - SN B40450099 and Lower

Please visit www.unverferth.com/parts/ for the most current parts listing.

ITEM	PART NO.	DESCRIPTION	QTY	NOTES
1	286379	Auger Driveshaft 2 1/2" Dia.	1	
2	283097G	Cover Plate =Green=	1	
	283097R	Cover Plate =Red=		
3	286282	Adapter/Shaft Bushing Weldment =Primed=	4	
4	286381B	Bearing Mounting Bar =Black=	1	
5	295739B	Rear Lower Auger Replacement Kit (Black)	1	
6	294130B	Front Horizontal Auger Replacement Kit (Black)	1	Includes Items 3, 7 - 10, 23
7	294136B	Front Lower Auger Weldment =Black=	1	
8	91299-157	Capscrew, 3/4"-10UNC x 6" Grade 8	2	
9	283535	Auger Tube Adapter	1	
10	283537	Auger Shaft 2.25" Dia.	1	
11	9002479	Adapter 1/8"-27 NPTF Male x 1/8"-27 NPSM Female Swivel Nut	1	
12	9002492	Bearing/Flanged 2" Dia.	1	
13	91267	Locknut 1/2"-13UNC	2	
14	9004731	Pillow Block Bearing with 2 1/2" Bore	1	
15	9004764	90° Elbow 1/8" Female NPTF x 1/8" Female NPTF	1	
16	9006964	Nipple 1/8" NPT Male x 1/8" NPT Male	1	
17	9002689	Hose 1/8" x 12", 3000 PSI	1	
18	9388-104	Carriage Bolt 1/2"-13UNC x 1 1/2" Grade 5	2	
19	91262	Flange Screw 3/8"-16UNC x 1" Grade 5	9	
20	286424B	Bearing Shim Plate =Black=	2	
21	9390-124	Capscrew 5/8"-11UNC x 2" Grade 5	6	
22	9390-160	Capscrew, 3/4"-10UNC x 7 1/2" Grade 5	4	
23	9802	Lock Nut, 3/4"-10UNC	6	
24	9394-014	Hex Nut, 5/8"-11UNC Grade 5	4	
25	9404-029	Lock Washer 5/8"	6	
26	283895	Spacer Bushing, 1 1/4" OD x 0.813" ID x 1 1/8"	4	
27	9005072	90° Elbow 1/4" Tube x 1/8"-27 NPTF Swivel Nut	1	
28	9005074	Grease Hose 1/4" OD	AR	

Auger Fold Linkage Components

Please visit www.unverferth.com/parts/ for the most current parts listing.

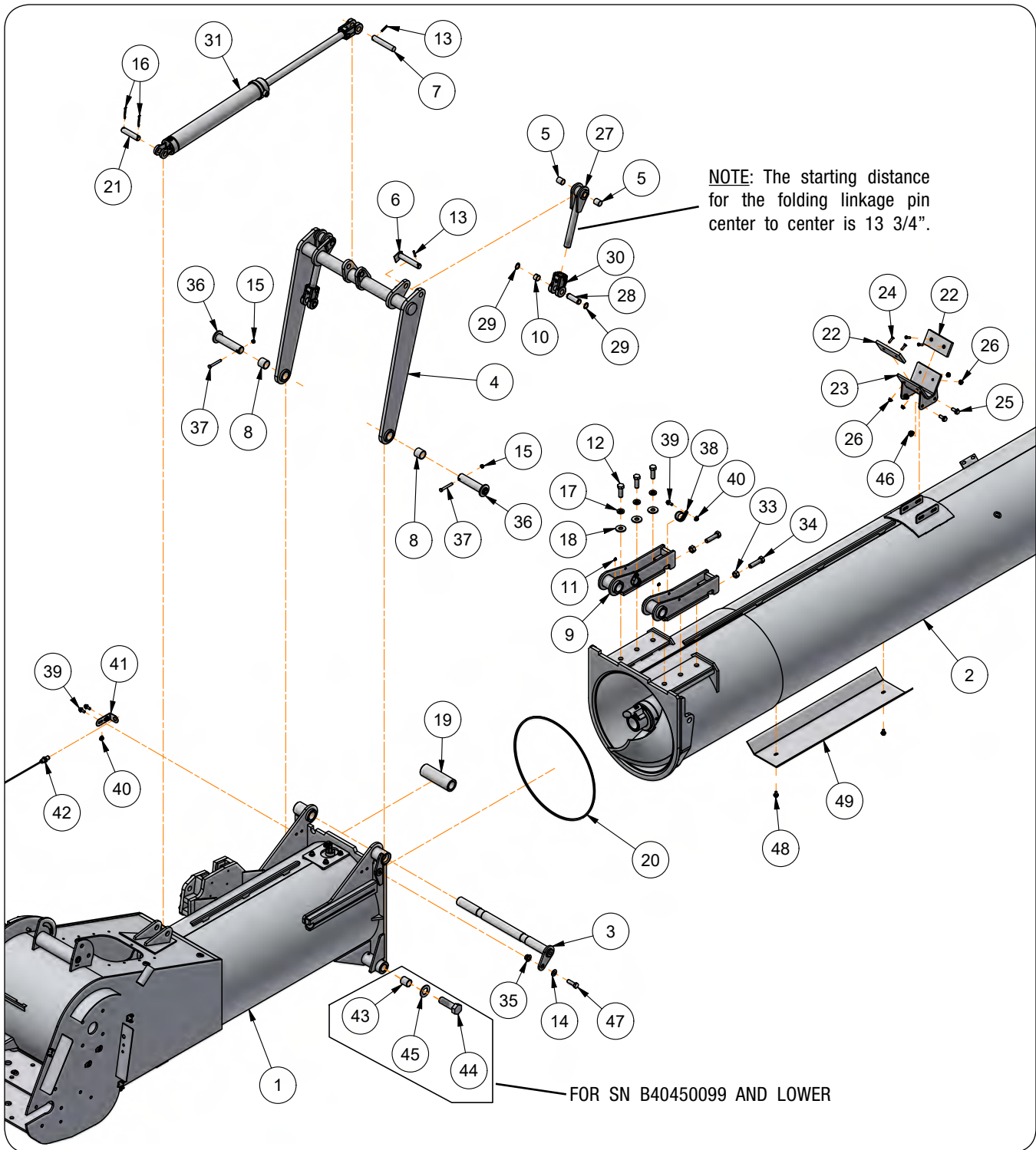

Auger Fold Linkage Components

Please visit www.unverferth.com/parts/ for the most current parts listing.

ITEM	PART NO.	DESCRIPTION	QTY	NOTES
1	294225G	Lower Auger Housing Replacement Kit (Green)	1	For SN B40450100 & Higher
	294225R	Lower Auger Housing Replacement Kit (Red)		
	287893G	Lower Auger Housing Replacement Kit (Green)		For SN B40450099 & Lower
	287893R	Lower Auger Housing Replacement Kit (Red)		
2	284438G	Upper Auger Housing Replacement Kit (Green)	1	
	284438R	Upper Auger Housing Replacement Kit (Red)		
3	289842	Auger Pivot Pin Weldment	1	For SN B40450100 & Higher
	284485	Auger Hinge Pin		For SN B40450099 & Lower
4	293960G	Auger Fold Linkage Weldment =Green=	1	For SN B40450100 & Higher
	293960R	Auger Fold Linkage Weldment =Red=		
	284510G	Over Center Latch Weldment =Green=		For SN B40450099 & Lower
	284510R	Over Center Latch Weldment =Red=		
5	9003440	Self Lube Bushing, 1.127" OD x 1" ID x 1.25"	4	
6	284555	Pin Weldment, 1" Dia. x 5 1/8"	2	
7	284557	Pin Weldment, 1" Dia. x 4 7/8"	1	
8	9004741	Self Lube Bushing, 1.75" OD x 1.50" ID x 1.50"	2	
9	286515G	Auger Hinge Weldment =Green=	2	
	286515R	Auger Hinge Weldment =Red=		
10	9003636	Self Lube Bushing, 1 1/8" OD x 1" ID x 3/4"	2	
11	91160	Grease Zerk	10	
12	91299-146	Capscrew, 3/4"-10UNC x 2 1/4" Grade 8	8	
13	9392-136	Roll Pin, 1/4" Dia. x 1 1/2"	3	
14	9405-098	Flat Washer, 5/8"	1	For SN B40450100 & Higher
	9395-010	Hex Jam Nut, 1/2"-13UNC Grade 5	2	For SN B40450099 & Lower
15	902875	Center Lock Nut, 3/8"-16UNC	2	For SN B40450100 & Higher
	9399-106	Set Screw, 1/2"-13UNC x 1/2" (Cup Point/Hex Socket)		For SN B40450099 & Lower
16	9391-046	Cotter Pin, 3/16" Dia. x 2"	2	
17	9404-034	Lock Washer, 3/4"	8	
18	9234PL	Flat Washer, 13/16" (Hardened)	8	
19	284493G	Middle Pivot Tube, 2 1/2" OD x 7 5/8" =Green=	1	
	284493R	Middle Pivot Tube, 2 1/2" OD x 7 5/8" =Red=		
20	296290	Lower Auger Seal	1	
21	266285	Cylinder Pin, 1" Dia. x 4 1/2"	1	
22	272574	Pad, 1/2" x 3" x 6 1/2"	2	
23	272553G	Auger Rest Weldment =Green=	1	
	272553R	Auger Rest Weldment =Red=		

(Continued on next page)

Auger Fold Linkage Components (continued)

Please visit www.unverferth.com/parts/ for the most current parts listing.

ITEM	PART NO.	DESCRIPTION	QTY	NOTES
24	903171-662	Flat Head Machine Screw, 5/16"-18UNC x 1 1/4"	4	
25	91266	Flange Screw, 1/2"-13UNC x 1 1/4" Grade 5	4	
26	91257	Large Hex Flange Nut, 5/16"-18UNC Grade 5	4	
27	284687	Fold Linkage Weldment	2	
28	272587	Pin, 1" Dia. x 3 1/8"	2	
29	91192	Retaining Ring, 1"	4	
30	9006491	Clevis	2	
31	9004730	Hydraulic Cylinder, 3" x 22" - 3000 PSI	1	
	9003772	Seal Kit	-	
32	92424	Hairpin Cotter	1	
33	9394-016	Hex Nut 3/4"-10UNC	2	
34	94733	Capscrew 3/4-10UNC x 3" Full Threaded	2	
35	9003398	Locknut 5/8"-11UNC	1	For SN B40450100 & Higher
36	293385	Auger Linkage Pin Weldment	2	For SN B40450100 & Higher
37	9390-063	Capscrew, 3/8"-16UNC x 3" Grade 5	2	For SN B40450100 & Higher
38	9008559	Cable Clamp, 1 1/2" Dia. x 3/4" (SS)	2	
39	91262	Flange Screw, 3/8"-16UNC x 1" Grade 5	4	
40	91263	Flange Nut, 3/8"-16UNC	4	
41	272645B	Switch Bracket =Black=	1	
42	9007223	Proximity Sensor	1	
43	284640	Pivot Bushing, 1.5" OD x 1.281" ID x 1.6875"	2	For SN B40450099 & Lower
44	9390-217	Capscrew, 1 1/4"-7UNC x 4" Grade 5	2	For SN B40450099 & Lower
45	9405-128	Flat Washer, 1 1/4"	2	For SN B40450099 & Lower
46	91267	Flange Nut, 1/2"-13UNC Grade 5		
47	9390-124	Capscrew, 5/8"-11UNC x 2" Grade 5	2	For SN B40450100 & Higher
	9390-102	Capscrew, 1/2"-13UNC x 1 3/4" Grade 5		For SN B40450099 & Lower
48	95585	Capscrew, 3/8"-16UNC x 3/4" Grade 5	2	
49	284141G	Strike Plate =Green=	1	
	284141R	Strike Plate =Red=		

Notes

Please visit www.unverferth.com/parts/ for the most current parts listing.

Downspout Components

Please visit www.unverferth.com/parts/ for the most current parts listing.

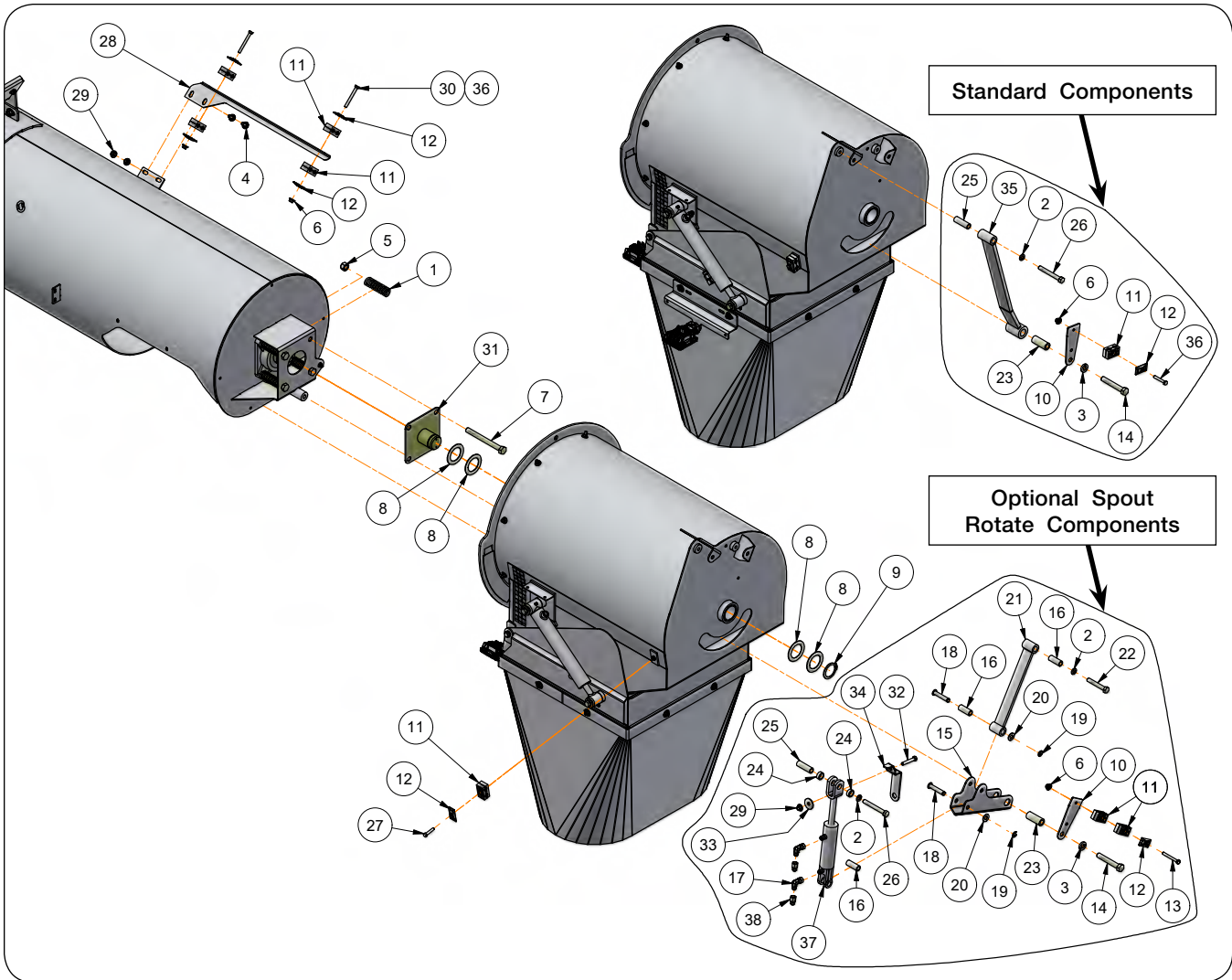

Downspout Components

Please visit www.unverferth.com/parts/ for the most current parts listing.

ITEM	PART NO.	DESCRIPTION	QTY	NOTES
1	9004899	Spring-Compression	4	
2	9404-025	Lock Washer, 1/2"	2	
3	9404-030	Lock Washer, 5/8" EXTRA	1	
4	95585	Capscrew/Lrg Flg, 3/8"-16UNC x 3/4" Gr.5	2	
5	9801	Locknut/Top, 5/8"-11UNC	4	
6	91257	Flange Nut, 5/16"-18UNC	3	
7	9390-137	Capscrew, 5/8"-11UNC x 6 1/2" Gr.5	4	
8	93974	Washer, 3" x 2"	4	
9	91178	Retaining Ring	1	
10	272620B	Plate-Hose Bracket =Black=	1	
11	9003816	Poly Clamp Pair (0.54")	4	Standard
			6	Optional Rotating Spout
12	9003814	Top Plate	4	Standard
			6	Optional Rotating Spout
13	9390-037	Capscrew, 5/16"-18UNC x 2 3/4" Gr.5	1	
14	9390-132	Capscrew, 5/8"-11UNC x 4" Gr.5	1	
15	284691B	Bracket-Linkage =Black=	1	
16	285290	Bushing-Sleeve 3/4" OD x .532" ID x 15/16"	3	
17	9876	90° Elbow, 9/16"-18 JIC M/F	2	
18	285219	Pin Weldment	2	
19	9005687	Snap Ring, 1/2"	2	
20	9405-086	Flat Washer, 1/2" SAE	2	
21	284699B	Linkage Weldment =Black=	1	
22	9390-108	Capscrew, 1/2"-13UNC x 3 1/4" Gr.5	1	
23	272619	Bushing-Sleeve 1" OD x .64" ID x 7/16" =Black=	1	
24	268905	Bushing Spacer 1" OD x 1/4" ID x 3/8"	2	
25	272571	Bushing-Sleeve 3/4" OD x .532" ID x 2 7/16"	1	
26	9390-111	Capscrew, 1/2"-13UNC x 4" Gr.5	1	
27	9390-032	Capscrew, 5/16"-18UNC x 1 1/2" Gr.5	1	
28	272570B	Plate-Hose Bracket =Black=	1	
29	91263	Large Flange Nut, 3/8"-16UNC	2	Standard
			3	Optional Rotating Spout
30	9390-038	Capscrew, 5/16"-18UNC x 2" Gr.5	2	Optional Rotating Spout
31	284986	Pin Weldment-Pivot, Hood	1	
32	9390-060	Capscrew, 3/8"-16UNC x 3" Gr.5	1	
33	9005696	Washer-Fender, 3/8"	1	
34	273876B	Plate-Switch Bracket =Black=	1	
35	271338B	Linkage Weldment =Black=	1	
36	9390-034	Capscrew, 5/16"-18UNC x 2" Gr.5	3	Standard
37	9007124	1 1/2" x 3" Hydraulic Cylinder	1	
	9005419	Seal Kit	-	
38	95193	Adapter 9/16"-18 JICF x 9/16"-18 JICM	2	0.030" Red Restrictor

Rotating Spout Components

Please visit www.unverferth.com/parts/ for the most current parts listing.

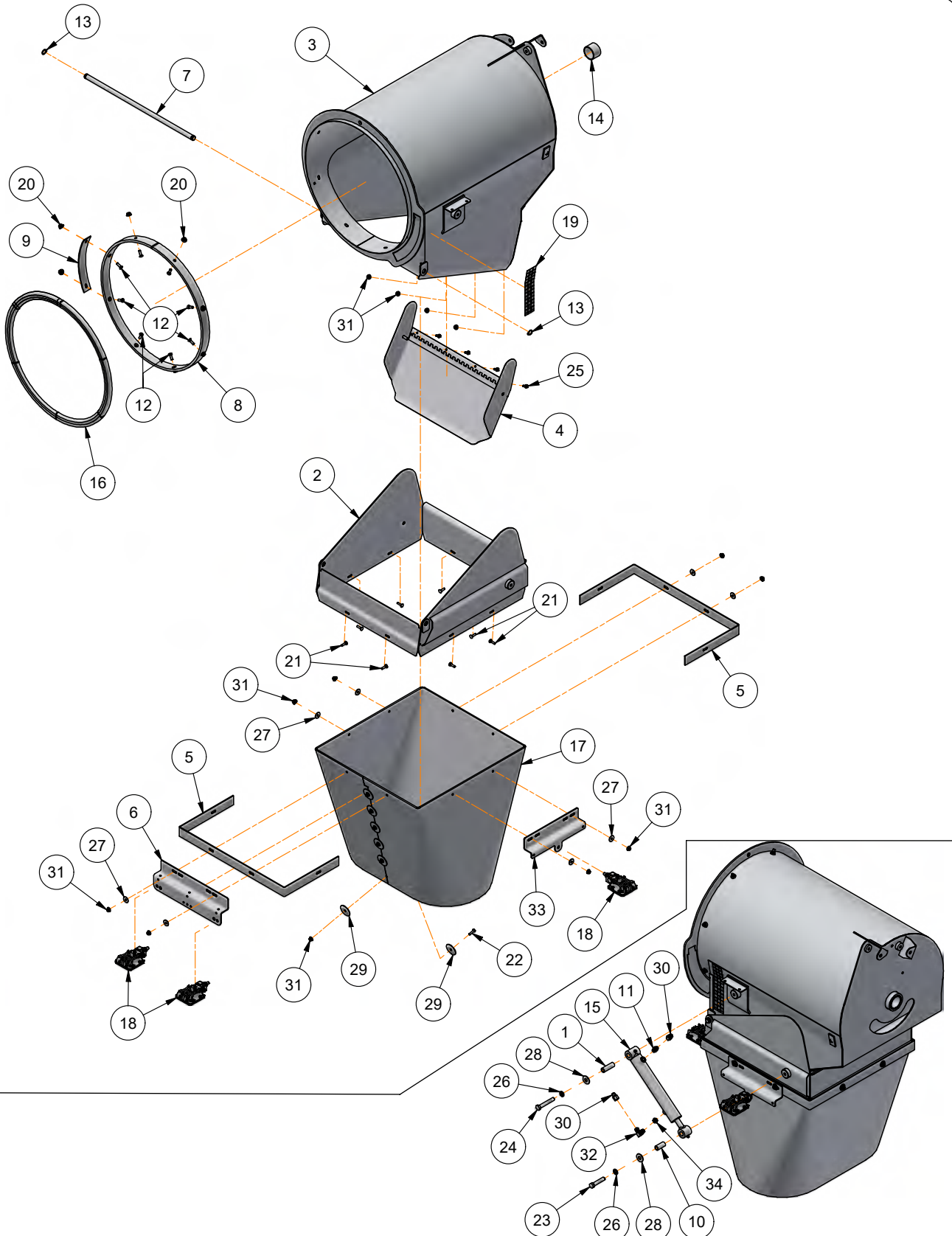

Rotating Spout Components

Please visit www.unverferth.com/parts/ for the most current parts listing.

ITEM	PART NO.	DESCRIPTION	QTY	NOTES
	289863B	Rotating Spout Assembly Less Rotating Cylinder (Black)	-	Includes Items 1 through 34
1	268571	Sleeve Bushing 3/4" Dia. x 0.532" Dia. x 2 3/8"	1	
2	272535B	Spout Weldment =Black=	1	
3	272542B	Hood Weldment =Black=	1	
4	272562B	Deflector Weldment =Black=	1	
5	272565B	Strap Chute Plate =Black=	2	
6	272646B	Light Bracket =Black=	1	
7	272596	Pivot Shaft	1	
8	272599	Wear Ring	1	
9	272600B	Hood Shim Plate =Black=	1	
10	273656	Sleeve Bushing 3/4" Dia. x 0.532" Dia. x 1 11/16"	1	
11	9001495	Adapter 9/16"-18 JIC Male x 9/16"-18 OR Male	1	
12	903171-660	Flat Countersunk Head Machine Screw 5/16"-18UNC x 1"	8	
13	9003810	External Retaining Ring 3/4"	2	
14	9005085	Self Lubricating Bushing 2 1/4" OD x 2" ID x 1 1/2"	1	
15	9005135	Cylinder 1 1/2" x 8"	1	
	9005419	Seal Kit	1	
16	9008122	Trim Seal	7	
17	9006421	Auger Hood 22"	1	
18	9008957	Work Light LED	3	
19	265384	Checker Decal	2	
20	91257	Hex Flange Nut 5/16"-18UNC Grade 5	8	
21	9388-003	Carriage Bolt 1/4"-20UNC x 1" Grade 5	8	
22	9390-005	Capscrew 1/4"-20UNC x 1" Grade 5	6	
23	9390-105	Capscrew 1/2"-13UNC x 2 1/2" Grade 5	1	
24	9390-108	Capscrew 1/2"-13UNC x 3 1/4" Grade 5	1	
25	97420	Flange Screw, 1/4"-20UNC x 3/4" Grade 5	4	
26	9404-025	Split Lock Washer, 1/2"	2	
27	9405-066	Fender Washer 1/4"	8	
28	9405-088	Flat Washer 1/2" USS	2	
29	94763	Fender Washer, 2" OD x 5/16" ID	12	
30	95193	Adapter 9/16"-18 JIC Female x 9/16"-18 JIC Male	2	
31	97189	Large Hex Flange Nut 1/4"-20UNC Grade 5	18	
32	97445	Elbow 90° 9/16"-18 JIC Male x 9/16"-18 OR ADJ Male	1	
33	272841B	Light Bracket =Black=	1	
34	9395-031	Hex Jam Nut 3/8"-16UNC Grade 5	1	

Spout Rotate Switch Assembly Components (Optional)

Please visit www.unverferth.com/parts/ for the most current parts listing.

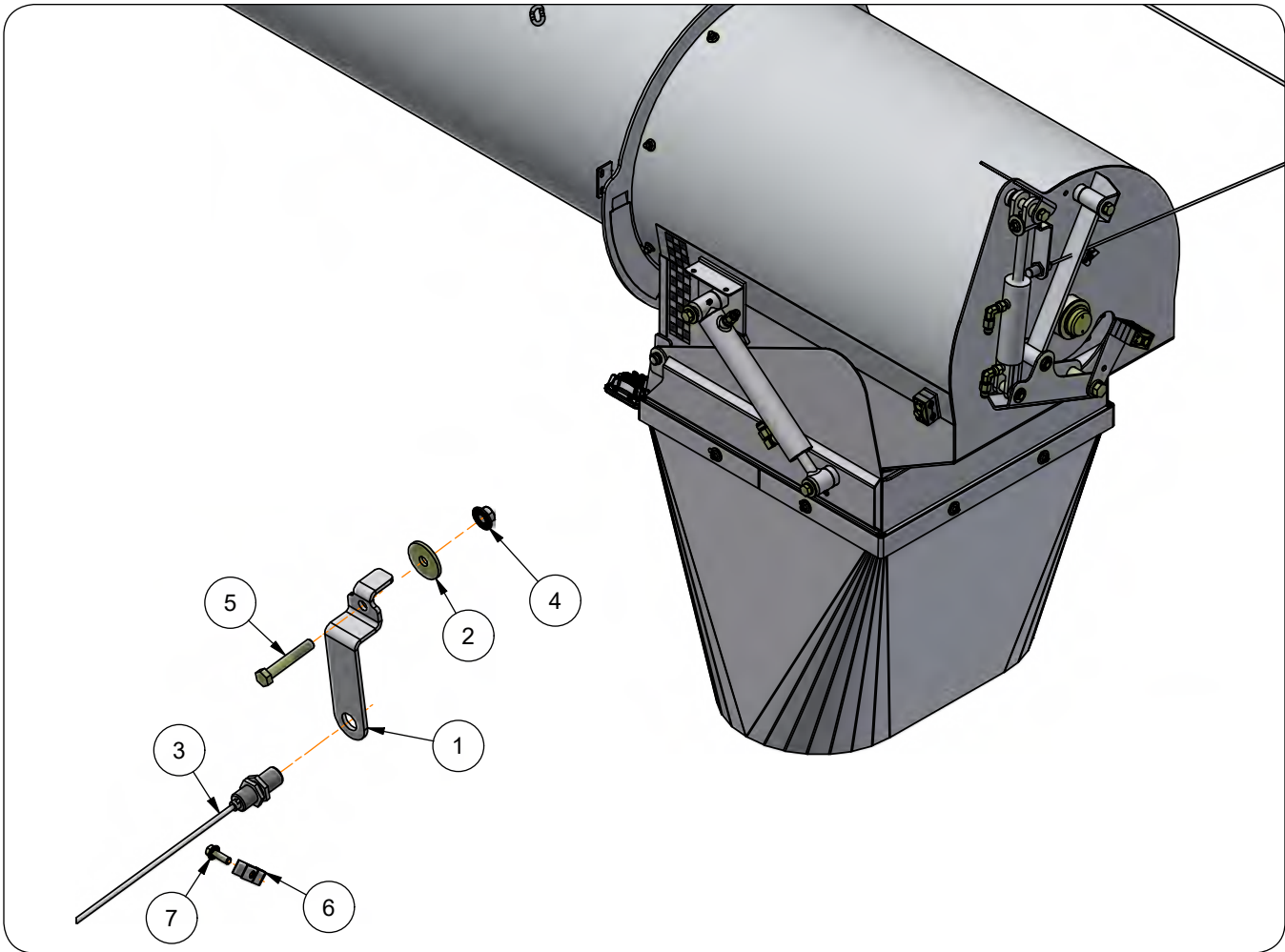

ITEM	PART NO.	DESCRIPTION	QTY	NOTES
1	273876B	Switch Plate Bracket =Black=	1	
2	9005696	Fender Washer, 3/8"	1	
3	9007223	Proximity Sensor with Connector	1	
4	91263	Large Flange Nut, 3/8"-16UNC Gr.5	1	
5	9390-060	Capscrew, 3/8"-16UNC x 2 1/4" Gr.5	1	
6	96728	Brake Line Clip	1	
7	97420	Flange Screw, 1/4"-20UNC x 3/4" Gr.5	1	

Notes

Please visit www.unverferth.com/parts/ for the most current parts listing.

Lower Auger Cleanout Door, Covers & Rest Components

Please visit www.unverferth.com/parts/ for the most current parts listing.

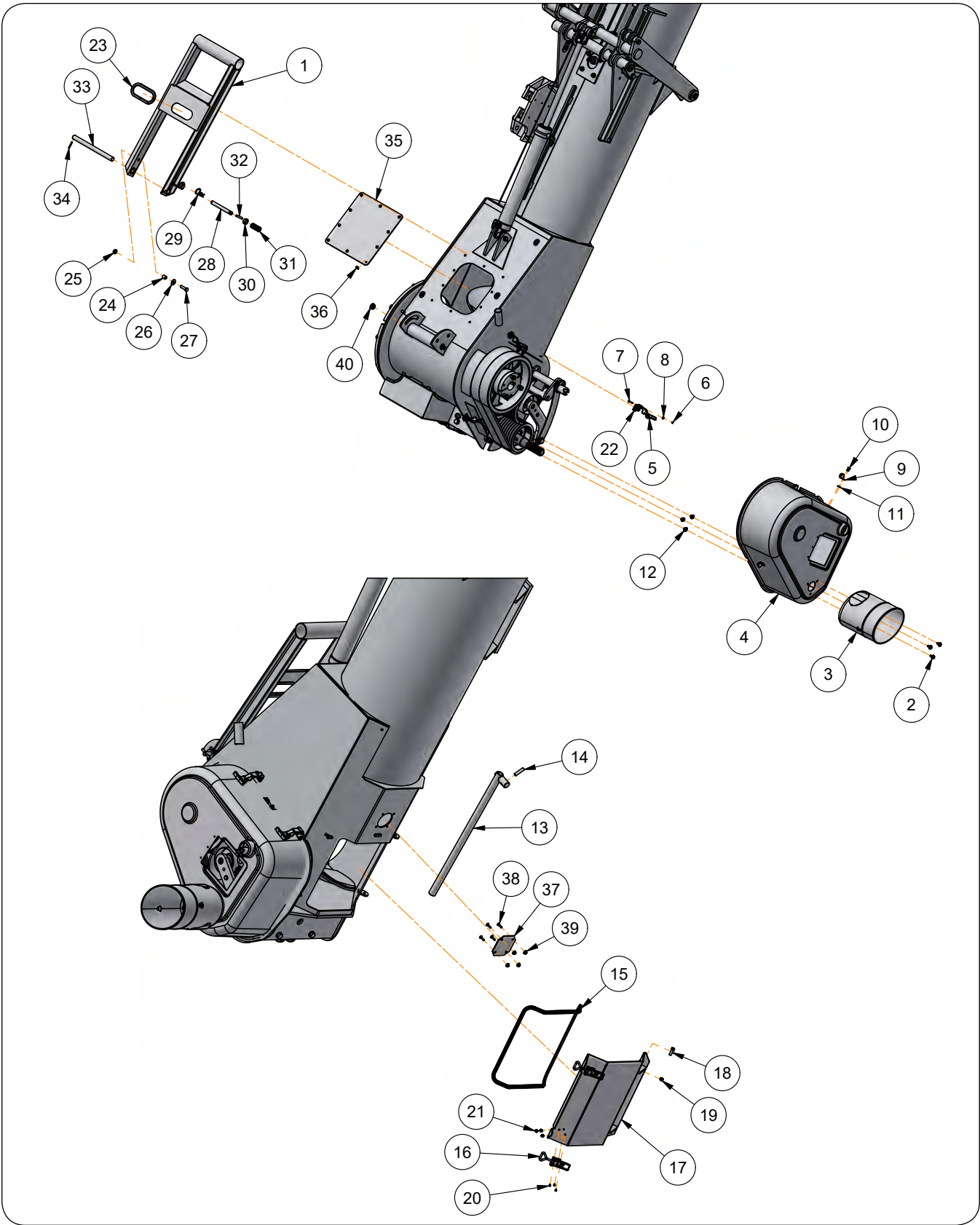

Lower Auger Cleanout Door, Covers & Rest Components

Please visit www.unverferth.com/parts/ for the most current parts listing.

ITEM	PART NO.	DESCRIPTION	QTY	NOTES
1	272579G	Auger Rest Weldment =Green=	1	
	272579R	Auger Rest Weldment =Red=		
2	95585	Capscrew/Large Flange 3/8"-16UNC x 3/4" Grade 5	3	
3	9004918	PTO Bell Cover	1	
4	9004729	Belt Cover/Shield	1	
5	900060	Handle for Draw Latch	3	
6	900068	"E" Retainer for Draw Latch	3	
7	900066	Stud Pin for Draw Latch	3	
8	900067	Washer for Draw Latch	3	
9	900059	Flexible Draw Latch Asy w/Style R Keeper	3	
10	9004940	Pop Rivet	6	
11	9004998	Rivet Washer/Burr 3/16"	6	
12	91263	Large Flange Nut 3/8"-16UNC Grade 5	3	
13	284714B	Belt Tensioner Handle With Roll Pin =Black=	1	
14	9392-208	Roll Pin 1/2" Dia. x 2"	1	
15	9007108	Gasket w/Adhesive Backing for Cleanout Door	A/R	Specify in Feet
16	9006497	Plate - Latch	2	
17	289854B	Cleanout Door Weldment =Black=	1	For SN B40450100 & Higher
	272595B			For SN B40450099 & Lower
18	9390-056	Capscrew 3/8-16UNC x 1 1/4" Grade 5	2	
19	9928	Locknut 3/8"-16UNC Grade 5	2	
20	903171-574	Flat Countersunk Screw #10-24UNC x 1/2"	6	
21	902331	Flange Hex Nut #10-24 (Serrated)	6	
22	900058	Draw Latch Base	3	
23	9000787	Trim Lock	1.25	Specify in Feet
24	272583	Stop Bushing, 3/4" Dia. x 7/8"	1	
25	9003397	Locking Flange Nut, 1/2"-13UNC Grade 5	1	
26	9405-088	Flat Washer, 1/2" USS	1	
27	9390-124	Capscrew, 5/8"-11UNC x 2" Grade 5	2	For SN B40450100 & Higher
	9390-102	Capscrew, 1/2"-13UNC x 1 3/4" Grade 5		For SN B40450099 & Lower
28	272376	Lock Pin, 3/4" Dia. x 6 3/4"	1	
29	92424	Hairpin Cotter	1	
30	9001868	Locking Collar, 3/4"	1	
31	9004772	Spring	1	
32	9392-182	Roll Pin, 3/8" Dia. x 2 1/2"	1	
33	284549	Pivot Pin, 1" Dia. x 13 1/16"	1	
34	9392-136	Roll Pin, 1/4" Dia. x 1 1/2"	1	
35	283518G	Cover Plate, 14 1/4" x 15" =Green=	1	
	283518R	Cover Plate, 14 1/4" x 15" =Red=	1	
36	97420	Flange Screw, 1/4"-20UNC x 3/4" Grade 5	10	
37	2001446B	Cover Plate, 4 1/2" x 4 1/2" =Black=	1	
38	9388-003	Carriage Bolt, 1/4"-20UNC x 1" Grade 5	4	
39	97189	Hex Nut/Large Flange, 1/4"-20UNC	4	
40	9003412	Split Output Bushing 1" ID	2	

Lower Auger Linkage Components

Please visit www.unverferth.com/parts/ for the most current parts listing.

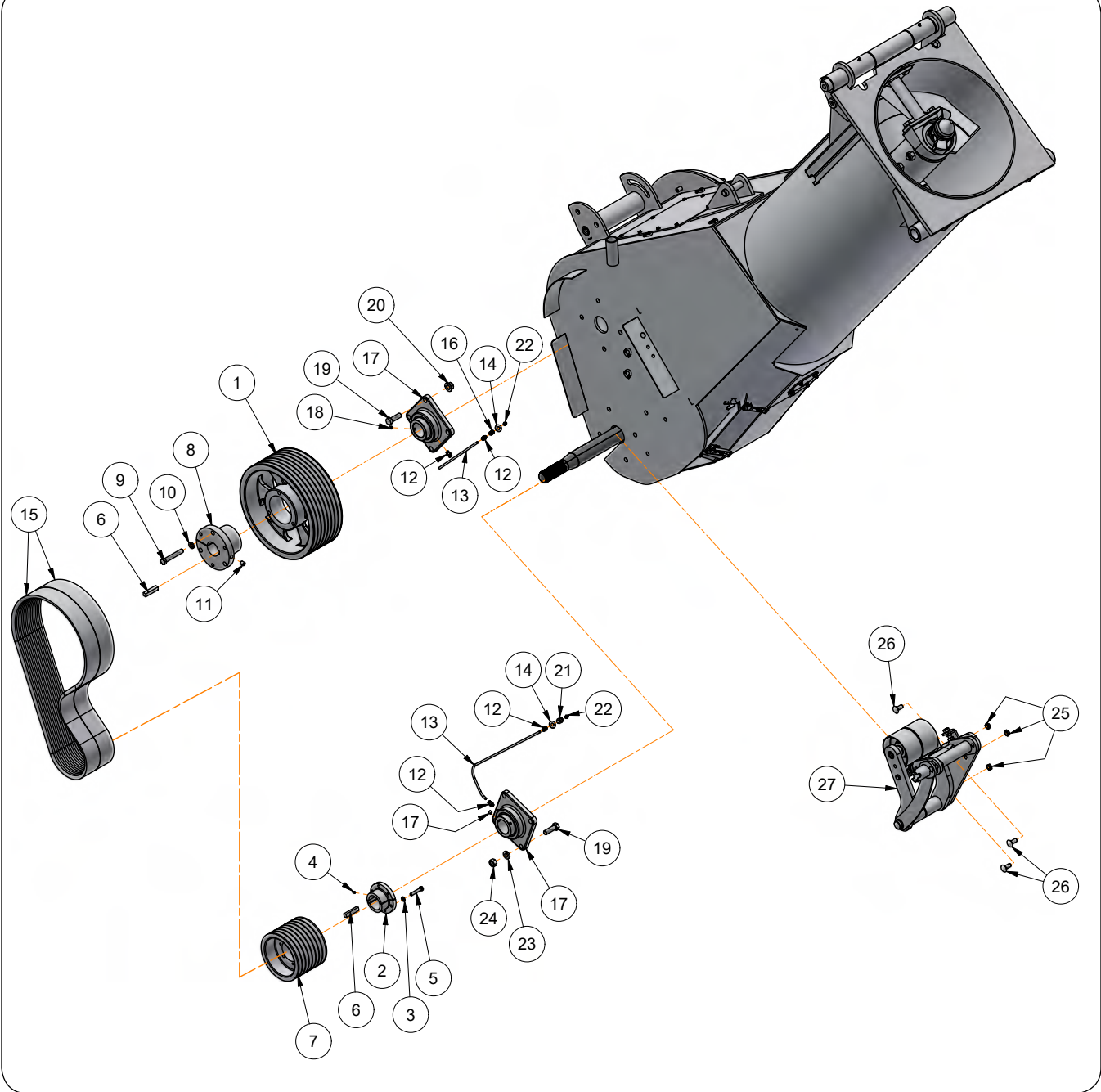

Lower Auger Linkage Components

Please visit www.unverferth.com/parts/ for the most current parts listing.

ITEM	PART NO.	DESCRIPTION	QTY	NOTES
1	9004590	Pulley, 15" Dia. x 5 13/16"	1	
2	9007376	Bushing, 4 5/8" OD x 2 1/4" ID x 2 1/16" With 1/2 Keyway & Includes Capscrews	1	Includes Items 3, 4, 5
3	9404-021	Lock Washer, 3/8"	3	
4	9399-059	Set Screw, 1/4"-20UNC x 3/8"	1	
5	284262	Split Bushing Hardware Kit	1	Includes Capscrews & Items 3 & 4
6	9002562	Keystock, 1/2" x 1/2" x 2 1/2"	2	
7	9004591	Pulley, 7 1/2" Dia. x 5 13/16"	1	
8	9004813	Bushing, 6 5/8" OD x 2 1/4" ID x 3 3/4" With 1/2" Keyway & Includes Capscrews	1	Includes Items 9, 10, 11
9	9006263	Bolt, 9/16"-12UNC x 3 5/8" Grade 5	3	
10	9404-027	Lock Washer, 9/16"	3	
11	9399-107	Set Screw, 1/2"-13UNC x 5/8"	1	
12	9005073	Quicklinc Fitting	4	
13	9005074	Grease Hose, 1/4" OD	2	(Specify in Feet)
14	9405-076	Flat Washer, 3/8"	2	
15	281675	Drive Belt Set, 4 Strand (5V750)	1	Included As Matched Pair
16	9003690	Hex Pipe Coupling	1	
17	9005565	Flange Bearing 2 1/4" ID - 4 Bolt	2	
18	9399-084	Set Screw 3/8"-16UNC x 3/8"	4	
19	9390-124	Capscrew, 5/8"-11UNC x 2" Grade 5	8	
20	9003398	Lock Nut/Top, 5/8"-11UNC	4	
21	9003949	Hex Pipe Coupling 1/8" NPTF	1	
22	93426	Grease Zerk, 1/8" NPT	2	
23	9404-030	Lock Washer, 5/8"	4	
24	9394-014	Hex Nut, 5/8"-11UNC Grade 5	4	
25	9008466	Lock Nut/Center Jam, 1/2"-13UNC	3	
26	9388-103	Carriage Bolt, 1/2"-13UNC x 1 1/4" Grade 5	3	
27	283600B	Idler Assembly (Black)	1	Refer to "Lower Auger Idler Assembly Components" for parts list

Lower Auger Idler Assembly Components

Please visit www.unverferth.com/parts/ for the most current parts listing.

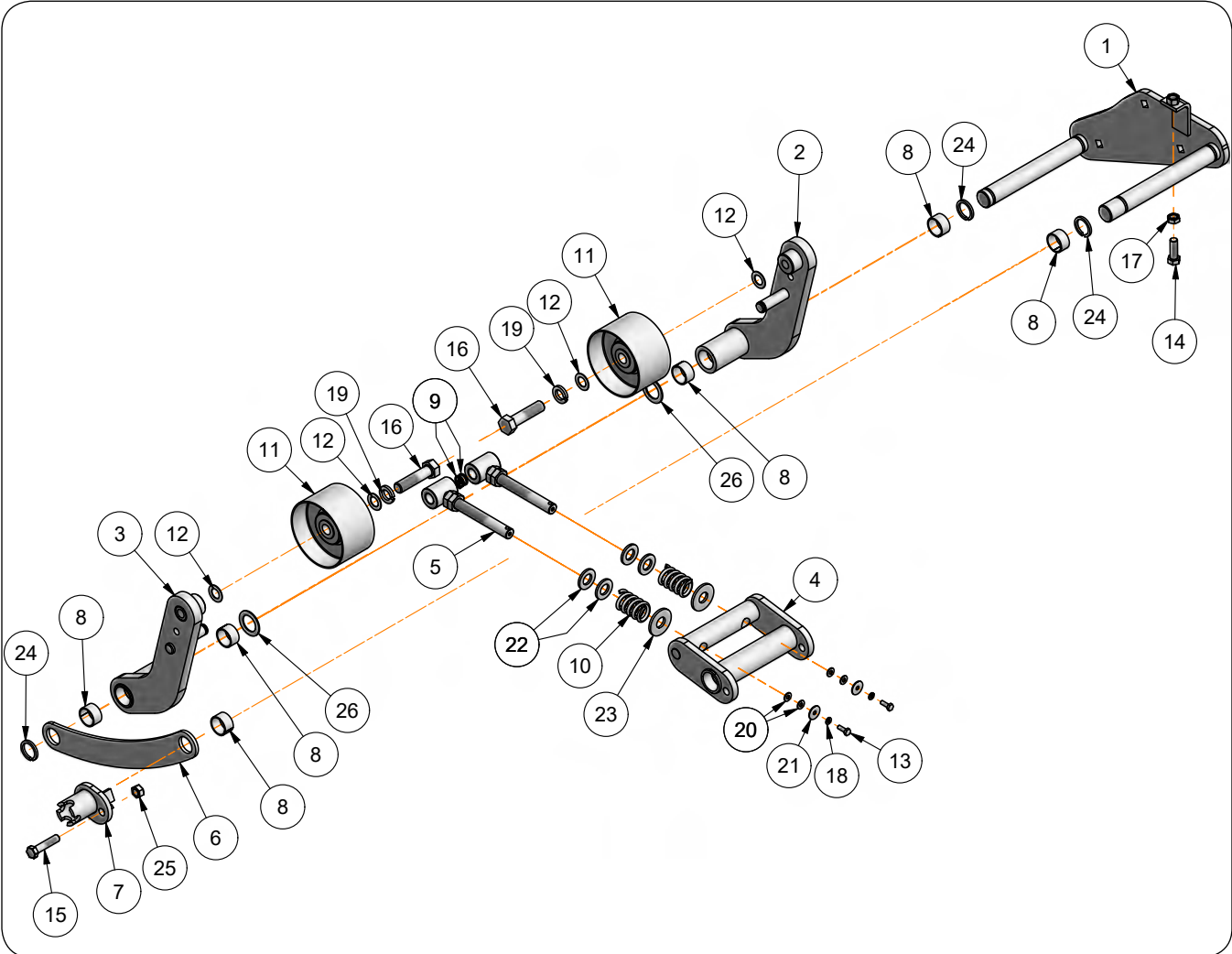

Lower Auger Idler Assembly Components

Please visit www.unverferth.com/parts/ for the most current parts listing.

ITEM	PART NO.	DESCRIPTION	QTY	NOTES
	283600B	Idler Assembly (Black)	1	Includes items 1-26
1	283601B	Idler Mount Weldment =Black=	1	
2	283602B	Inner Idler Arm Weldment =Black=	1	
3	283603B	Outer Idler Arm Weldment =Black=	1	
4	283604B	Tensioner Weldment =Black=	1	
5	283605	Tensioner Rod Weldment	2	
6	283619B	Idler Brace Plate =Black=	1	
7	284703	Tensioner Bushing Weldment	1	
8	9003635	Self-Lubricating Bushing, 1.4" OD x 1.25" ID x 3/4"	6	
9	9003810	Snap Ring	2	
10	9005447	Compression Spring, 1.415" OD x 2 1/2"	2	
11	9005684	Idler Pulley	2	Single Piece Item
	296744B	Idler Pulley Assembly =Black=		Includes Ball Bearing W/Retaining Ring 2"
12	9005685	Machine Washer, 3/4"	4	
13	9390-003	Capscrew, 1/4-20UNC x 3/4" G5	2	
14	9390-101	Capscrew, 1/2"-13UNC x 1 1/2" G5	1	
15	9390-104	Capscrew, 1/2"-13UNC x 2 1/4" G5	1	
16	9390-149	Capscrew, 3/4"-10UNC x 3" G5	2	
17	9395-010	Hex Jam Nut, 1/2"-13UNC	1	
18	9404-017	Lock Washer, 1/4"	2	
19	9404-033	Lock Washer, 3/4"	2	
20	9405-062	Flat Washer, 1/4" SAE	4	
21	9405-066	Flat Washer, 1/4"	2	
22	9405-104	Flat Washer, 3/4" SAE	4	
23	9405-106	Flat Washer, 3/4" USS	2	
24	94144	Retaining Ring, 1 1/4"	4	
25	94981	Locknut, 1/2"-13UNC	1	
26	TA500397	Bushing, 1.875"D x .074"	2	

Lower Auger Retainer Components

Please visit www.unverferth.com/parts/ for the most current parts listing.

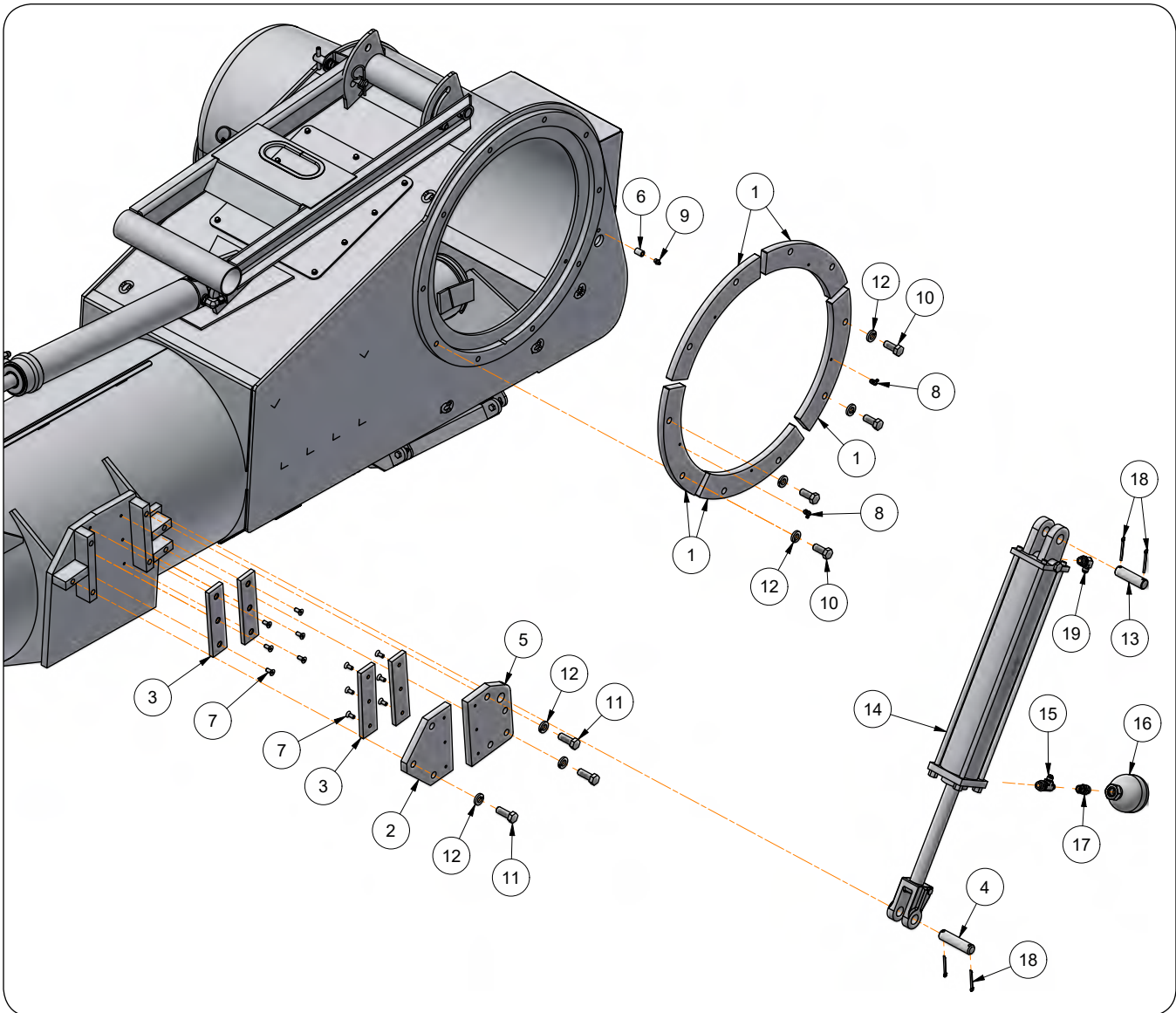

Lower Auger Retainer Components

Please visit www.unverferth.com/parts/ for the most current parts listing.

ITEM	PART NO.	DESCRIPTION	QTY	NOTES
1	284464B	Pivot Retainer Plate, 4 3/8" x 15 1/16" =Black=	5	
2	271119B	Fold Plate, 6 1/2" x 8" =Black=	1	
3	271124	Nylon Fold Slide, 2" x 8"	4	
4	250104	Pin, 1" Dia. x 4"	1	
5	284518B	Fold Plate, 6" x 8" =Black=	1	
6	9002538	Pipe Coupling, 1/8" NPT	1	
7	9001688	Flat Head Hex Socket Capscrew, 5/16"-18UNC x 3/4"	12	
8	93415	90° Grease Zerk, 1/4"-28 NPT	5	
9	93426	Grease Zerk, 1/8"-27 NPT	1	
10	9390-122	Capscrew, 5/8"-11UNC x 1 1/2" G5	10	
11	9390-123	Capscrew, 5/8"-11UNC x 1 3/4" G5	7	
12	9404-030	Lock Washer, 5/8"	17	
13	804572	Pin, 1" Dia. x 3 1/2"	1	
14	9000933	Hydraulic Cylinder, 3 1/2" x 20"	1	
	9001081	Seal Kit	-	
15	9002155	Tee, 9/16"-18 JICM x 3/4"-16 O-RM x 9/16"-18 JICM	1	
16	9002719	Accumulator, 1800 PSI - Precharge Temp Range 14-176 Deg.	1	
17	9002720	Adapter, 3/4"-16 O-Ring Male x 9/16"-18 JIC Female Swivel Nut	1	
18	9391-046	Cotter Pin, 3/16" Dia. x 2"	4	
19	9874	90° Elbow, 9/16"-18 JICM x 3/4"-16 O-RM	1	

Cut Out Clutch PTO Assembly - Benzi

Please visit www.unverferth.com/parts/ for the most current parts listing.

FOR Benzi PTO, U-Joint color is Gray.

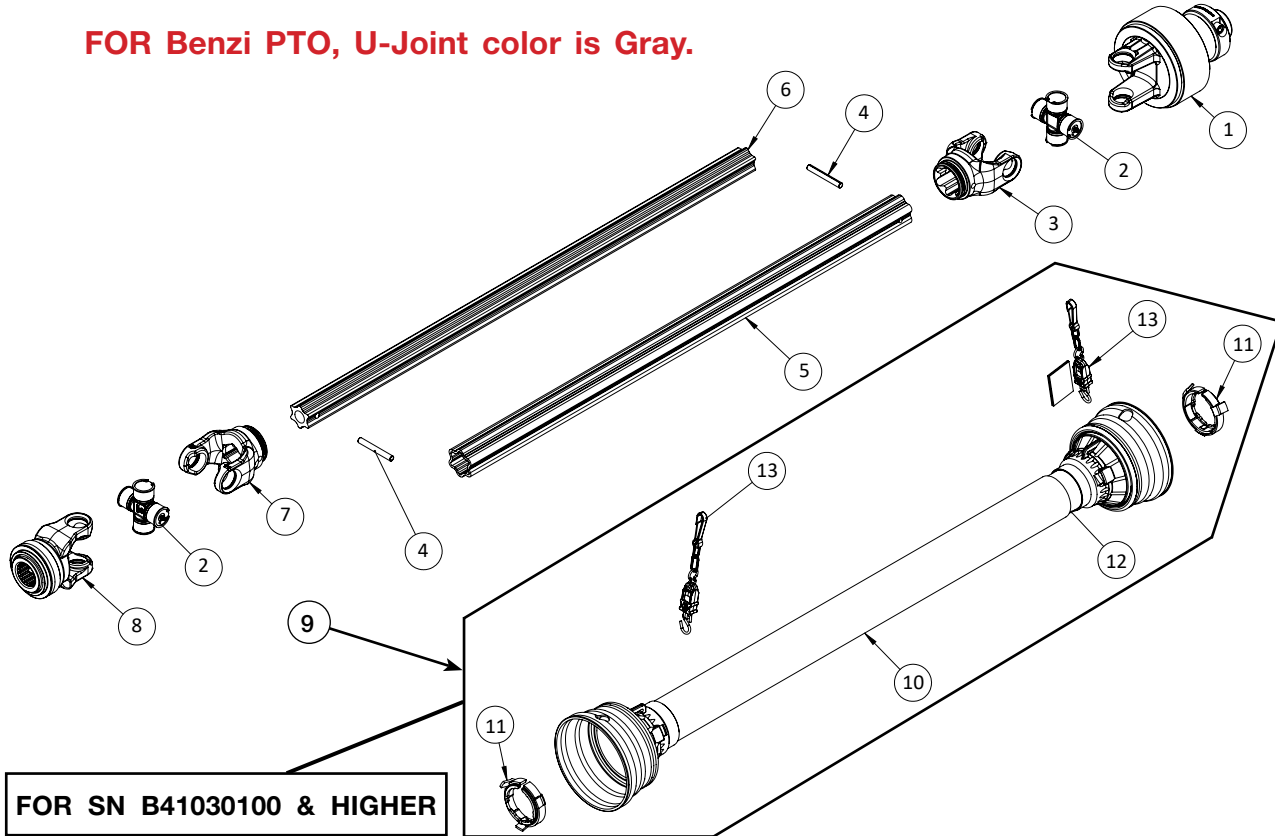

ITEM	PART NO.	DESCRIPTION	QTY	NOTES	
	9008527	Complete Driveline Assembly 1 3/4"-20 Spline	1	Includes Items 1-9	
	9009250	Front Half Driveline Assembly 1 3/4"-20 Spline w/Overrunning Clutch	1	Includes Items 2, 4, & 6-9	
	9009251	Rear Half Driveline Assembly 1 3/4"-20 Spline w/CAM Cut Out Clutch	1	Includes items 1-5 & 9	
1	9008791	Clutch Assembly (3200 N*m Setting)	1	1 3/4"-20 Spline 1000RPM	
2	9008792	U-Joint Assembly	2		
3	9008793	Outer Yoke	1		
4	9008794	Tension Pin	2		
5	9008795	Outer Profile Tube w/ Cap	1		
6	9008796	Inner Profile Tube w/ Cap	1		
7	9008797	Inner Yoke	1		
8	9008798	Yoke Assembly	1		
9	9009188	Safety Guard Assembly	1	For SN B41030100 & Higher Includes Items 10 - 13	
	10	N/A	Outer Guard Half	1	Not For Individual Sale. See Item 9
	11	9008801	Guarding Cone Retainer Clip Package	1	Package of 2
	12	N/A	Inner Guard Half	1	Not For Individual Sale. See Item 9
	13	9008804	Chain	2	

Cut Out Clutch PTO Assembly - Benzi

Please visit www.unverferth.com/parts/ for the most current parts listing.

FOR Benzi PTO, U-Joint color is Gray.

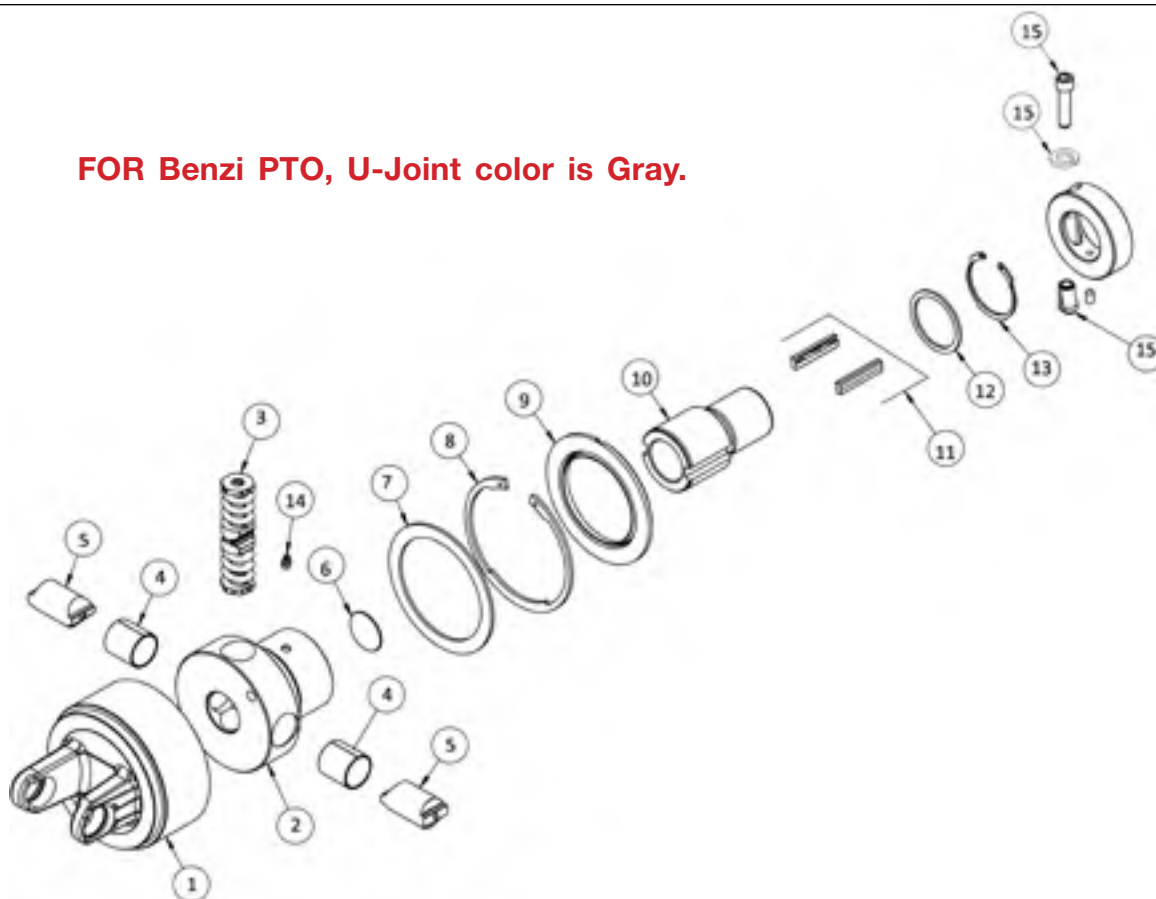

NOTE: Clutch Assembly (9008791) must be used with the Complete PTO Assembly (9008527).

ITEM	PART NO.	DESCRIPTION	QTY	NOTES
	9008791	Cut Out Clutch (3200 N*m Setting)		Includes Items 1-15
1	9008775	Housing Weld	1	
2	9008776	Cam Clutch Hub 1 3/4"-20 Spline	1	
3	9008777	Automatic Cam Clutch	1	
4	9008778	Bushing	2	
5	9008779	Pusher Rod	2	
6	9008780	Closer Ring	1	
7	9008781	Washer 6 5/8" Dia.	1	
8	9008782	Circlip 6 5/8" Dia.	1	
9	9008783	Seal Ring	1	
10	9008784	Overrunning Clutch Hub	1	Includes Collar With Set Screw
11	9008785	Spring Pack	1	
12	9008786	Washer	1	
13	9008787	Circlip	1	
14	9008788	Grease Zerk (M8)	1	
15	9008789	Conic Bolt Set	1	Includes Socket Head Bolt, Lock Washer, and Threaded Insert

Cut Out Clutch PTO Assembly - Walterscheid

Please visit www.unverferth.com/parts/ for the most current parts listing.

FOR Walterscheid PTO, U-Joint color is Yellow.

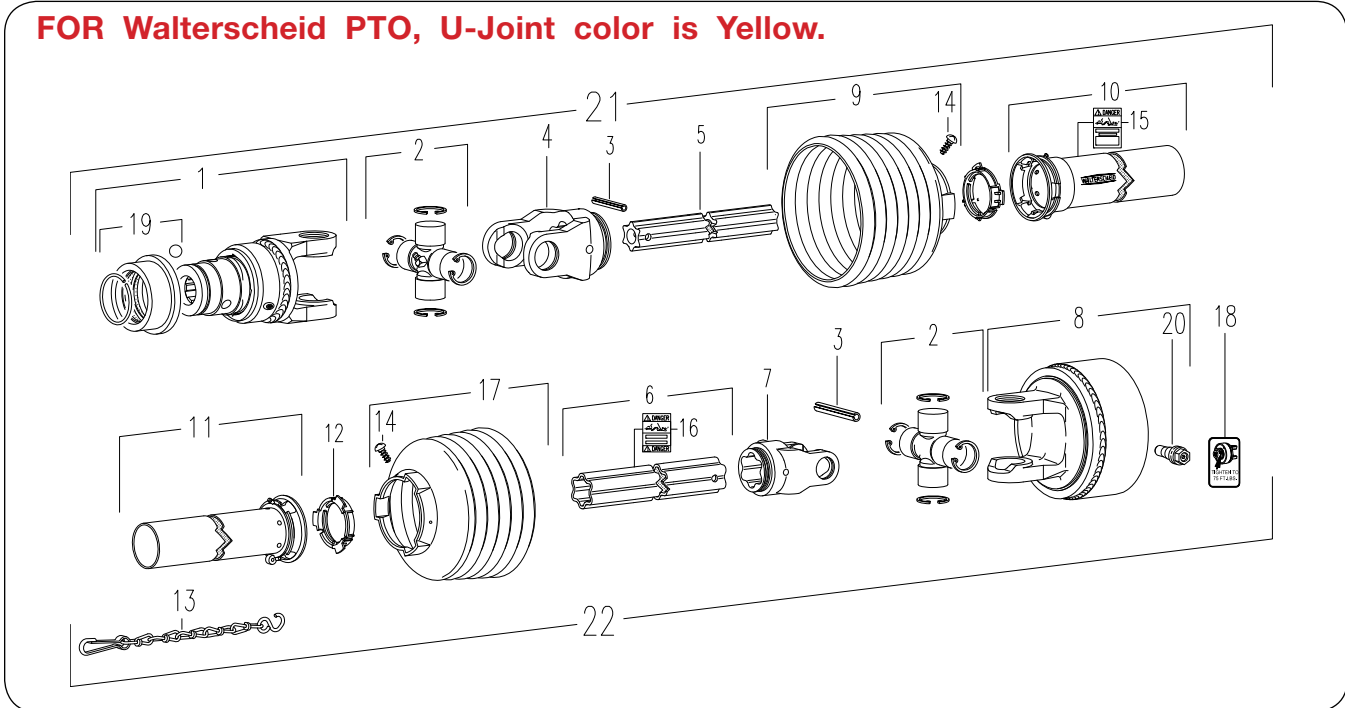

ITEM	PART NO.	DESCRIPTION	QTY	NOTES
	9005230	PTO Assembly Complete		Includes Items 19 & 20
1	9005234	Over-Running PTO Clutch Assembly	1	1 3/4"-20 Spline 1000RPM
2	92529	Cross & Bearing Kit	2	
3	9002609	Spring Pin 10x90	2	
4	9002610	Inboard Yoke S4	1	
5	9004840	Inner Profile	1	
6	9004841	Outer Profile	1	
7	9002613	Inboard Yoke S5	1	
8	9005235	Cut Out Clutch (3200 N-m Setting)	1	1 3/4"-20 Spline 1000RPM
9	9002615	Shield Cone 7 Rib	1	
10	9004843	Outer Shield Tube Oval	1	
11	9004844	Inner Shield Tube Oval	1	
12	92373	Bearing Ring	2	
13	92374	Safety Chain	1	
14	92372	Screw	2	
15	92377	Decal Out	1	
16	92378	Decal In	1	
17	93866	Shield Cone 6 Rib	1	
18	9005233	Decal K64	1	"Tighten to 75 Ft.-Lbs."
19	93856	Quick-Disconnect Kit	1	1 3/4"-20 Spline w/Metal Collar
20	9005253	Clutch Clamp Cone Assembly	1	
21	9005231	PTO Front Half Assembly 1 3/4"-20 Spline	1	
22	9005232	PTO Rear Half Assembly 1 3/4"-20 Spline	1	
23	9002513	Reinforcing Collar	1	NOT SHOWN

Cut Out Clutch Components - Walterscheid

Please visit www.unverferth.com/parts/ for the most current parts listing.

FOR Walterscheid PTO, U-Joint color is Yellow.

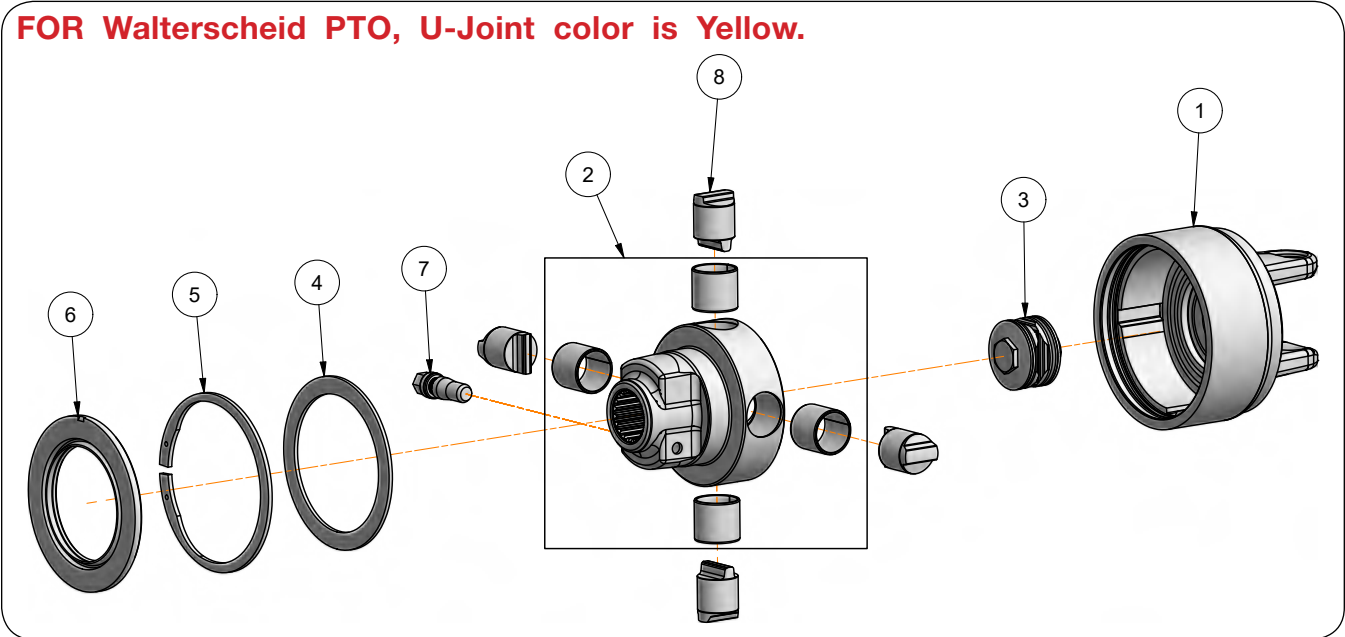

NOTE: Cut Out Clutch (9005235) must be used with the Complete PTO Assembly (9005230). This will not work with the Friction Clutch PTO Assembly (9005245).

ITEM	PART NO.	DESCRIPTION	QTY	NOTES
	9005235	Cut Out Clutch (3200 N*m Setting)		Includes Items 1-8
1	9005247	Clutch Housing	1	
2	9005248	Clutch Hub 1 3/4"-20 Spline	1	
3	9005249	Spring Pack	1	
4	9005250	Washer	1	
5	9005251	Retaining Ring	1	
6	9005252	Sealing Ring	1	
7	9005253	Clutch Clamp Cone Assembly	1	
8	9005254	Clutch Cam	4	

Gearbox Components

Please visit www.unverferth.com/parts/ for the most current parts listing.

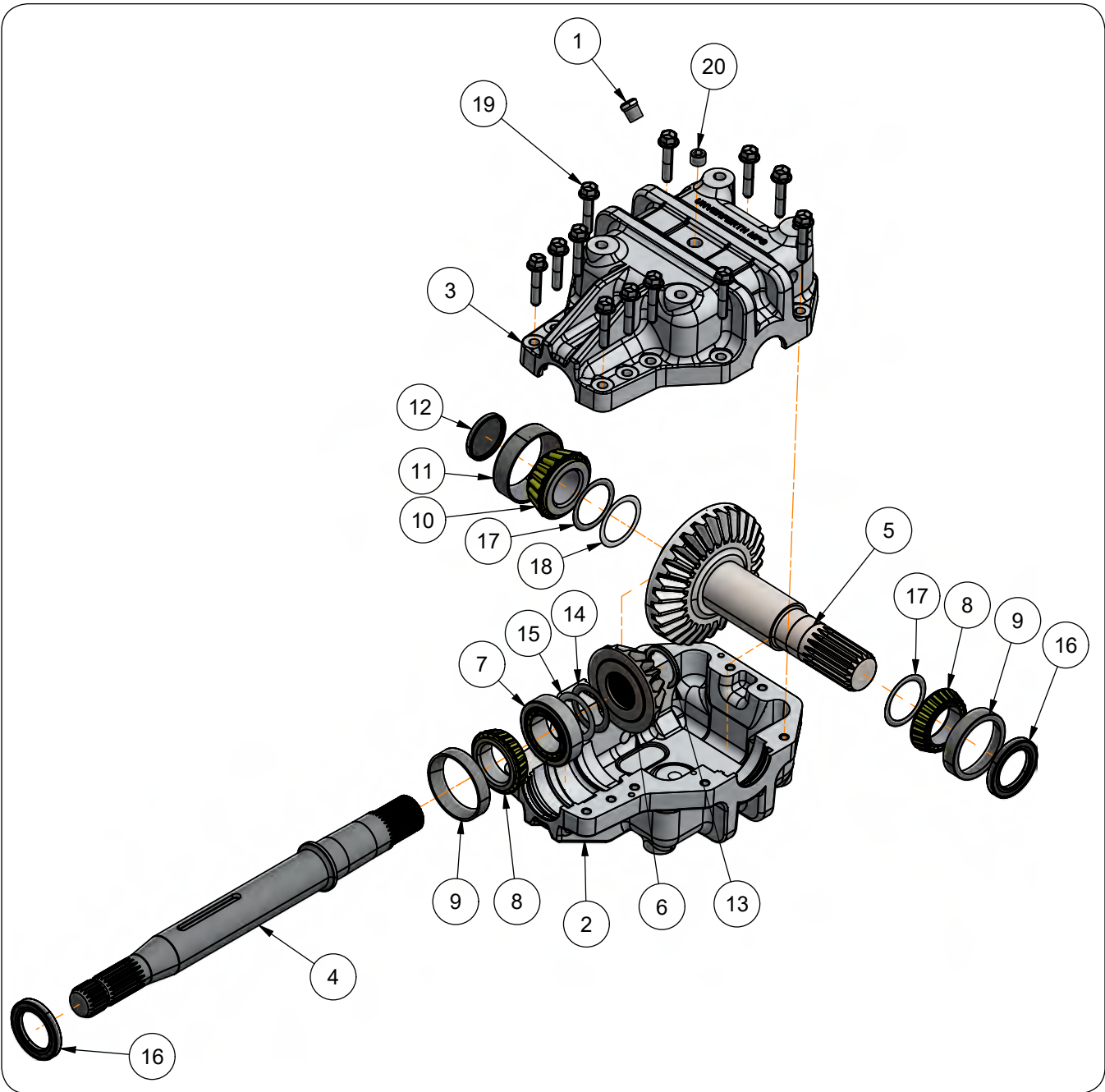

Gearbox Components

Please visit www.unverferth.com/parts/ for the most current parts listing.

ITEM	PART NO.	DESCRIPTION	QTY	NOTES
	9007366	Gearbox Complete	1	Includes Items 1 through 20
1	9006381	Glass Sight Plug	2	
2	9007492	Gearbox Housing Q800 w/Taped Holes	1	
3	9007493	Gearbox Housing Q800 w/Through Holes	1	
4	9007494	Gearbox Shaft 2 1/4" Dia.	1	
5	9007495	Gear Shaft Assembly 29 Tooth, 2 1/4"-17 Spline	1	
6	9007496	Gear 16 Tooth Splined	1	
7	9007497	Bearing Cup & Cone Set, 3.740" OD x 1 1/4"	1	
8	9007498	Bearing Cone 2 1/4" ID x 1"	2	
9	9007499	Bearing Cup 3.8437" OD x 0.7812"	2	
10	9007500	Bearing Cone 2" ID x 1.5312"	1	
11	9007501	Bearing Cup 4.125" OD	1	
12	9007502	End Cap	1	
13	9007503	Retaining Ring - External 2" Nominal Shaft Dia.	1	
14	9007504	Shim - 0.025"	1	
15	9007505	Shim - 0.030"	1	
16	9007508	Shaft Seal	2	
17	9007511	Shim - 0.005"	2	
18	9007512	Shim - 0.003"	1	
19	903161-060	Flange Screw 1/2"-13UNC x 2 1/2"	12	
20	95283	Plug	3	

EOH Valve Assembly Components Optional

Please visit www.unverferth.com/parts/ for the most current parts listing.

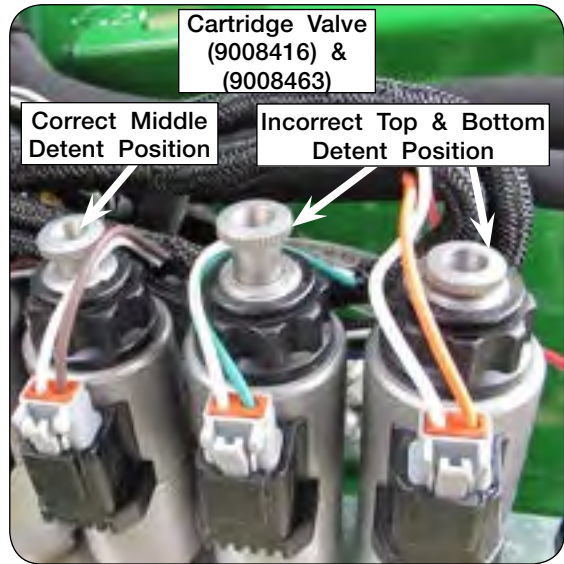
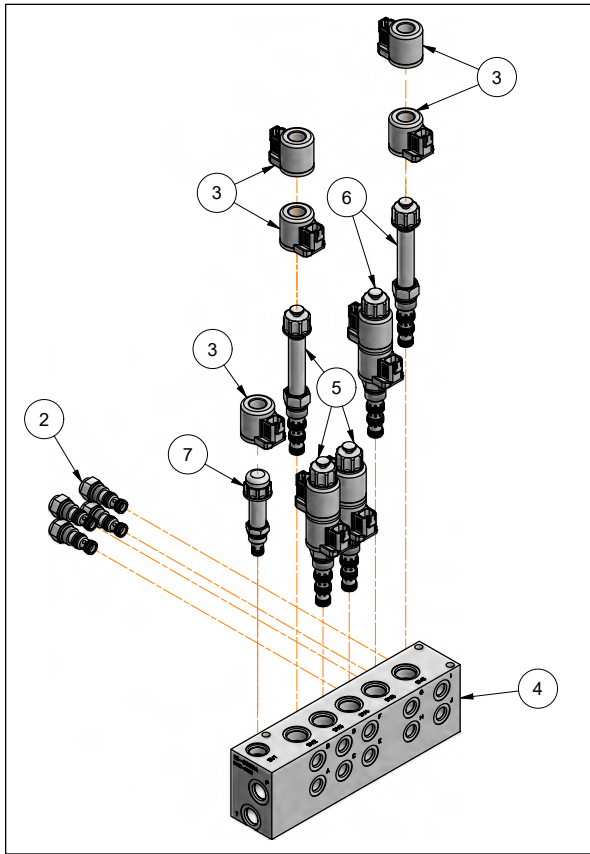

Cartridge Valve (9008416) & (9008463)
Middle Detent Position

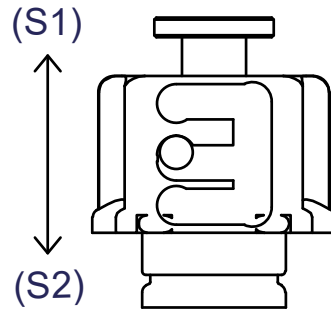

PUSH BUTTON
AND HOLD
WHILE OPERATING
INDIVIDUAL FUNCTIONS

Cartridge Valve (9008438)

FOR MANUAL OVERRIDE

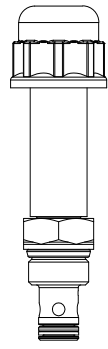

NOTE: REFER TO "MANUAL OVERRIDE FOR OPTIONAL ELECTRIC OVER HYDRAULIC SYSTEM" IN MAINTENANCE SECTION.

EOH Valve Assembly Components Optional

Please visit www.unverferth.com/parts/ for the most current parts listing.

ITEM	PART NO.	DESCRIPTION	QTY.	NOTES
1	293416	EOH Block Assembly - 5 Spool Replacement Kit	1	Includes Items 2-7 and Instruction Sheet
2	9003856	Pilot Check Valve	4	
3	9005769	Coil - 12 VDC DN-40	11	
4	9008667	Manifold Block - 5 Spool	1	
5	9008416	Cartridge Valve - 4 Way, 3 Position - Closed Center w/Detented Manual Override	3	Includes Retaining Cap
	9003906	Seal Kit	-	
6	9008463	Cartridge Valve - 4 Way, 3 Position - Open Center w/Detented Manual Override	2	Includes Retaining Cap
	9003906	Seal Kit	-	
7	9008438	Cartridge Valve - 2 Way, 2 Position w/Push Type Manual Override	1	
	9003904	Seal Kit	-	

EOH Valve Functions and Wire Locations - Optional

Please visit www.unverferth.com/parts/ for the most current parts listing.

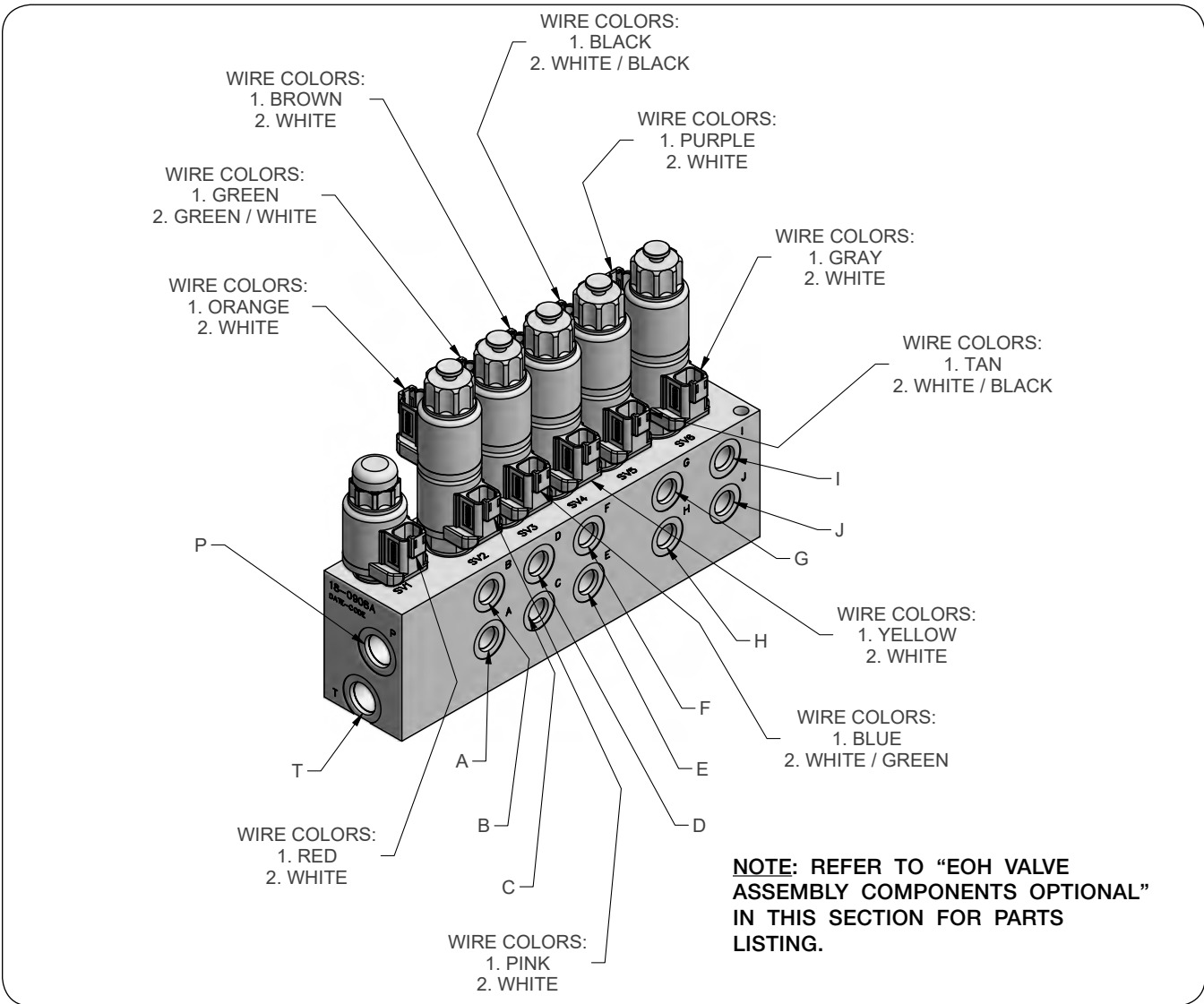

PORT	END OF CYLINDER	FUNCTION
A	BUTT END	Flow Door
B	RAM END	Flow Door
C	RAM END	Auger Fold
D	BUTT END	Auger Fold
E	RAM END	Spout Tilt Out
F	BUTT END	Spout Tilt In
G	RAM END	Joystick / Spout Rotate Back
H	BUTT END	Joystick / Spout Rotate Front
I	BUTT END	Auger Pivot Down
J	RAM END	Auger Pivot Up
P		Tractor Pressure
T		Tractor Return

EOH Tractor Circuit Hydraulic Components - Optional

Please visit www.unverferth.com/parts/ for the most current parts listing.

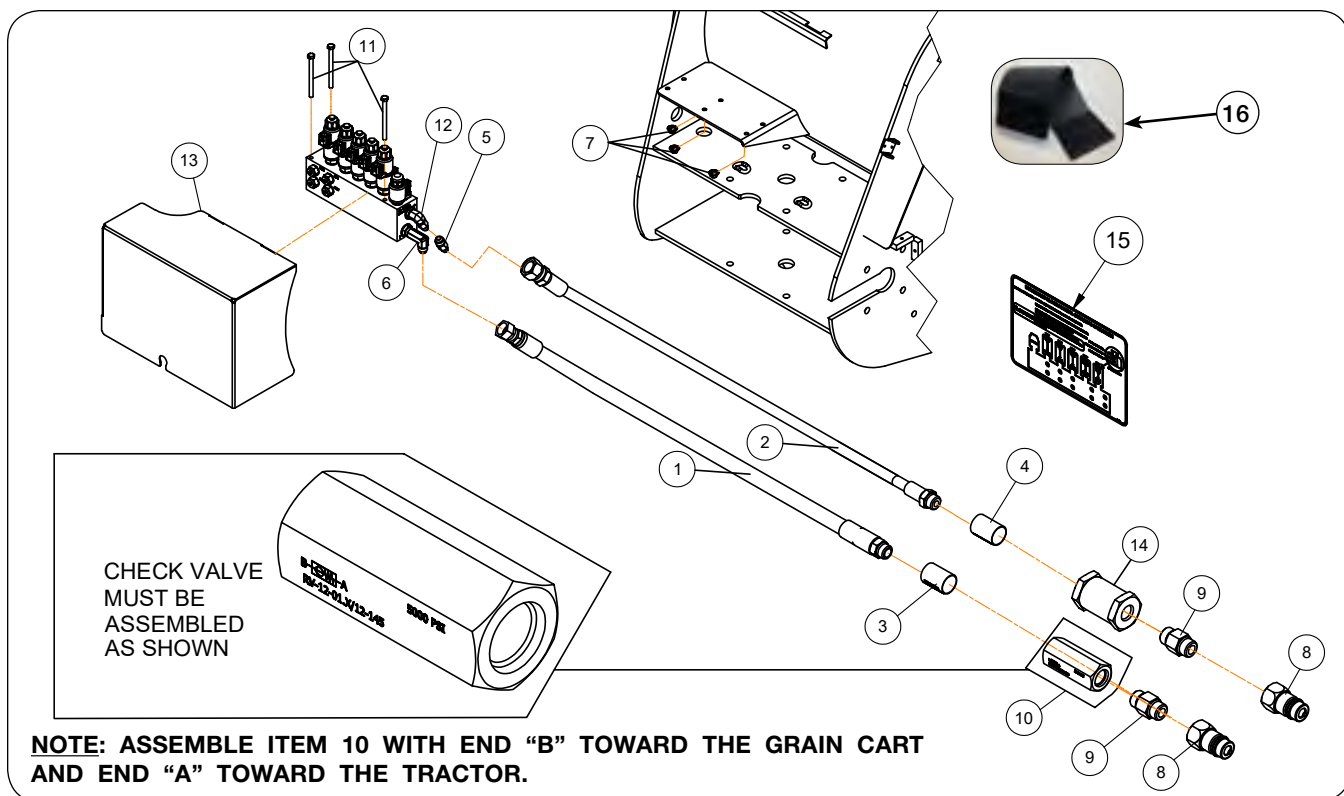

ITEM	PART NO.	DESCRIPTION	QTY.	NOTES
1	95802	Hydraulic Hose, 1/2" x 205" - 3000 PSI	1	
2	9005574	Hydraulic Hose, 1/4" x 208" - 3000 PSI	1	
3	9005983	Hose Marker Sleeve - Hydraulic Return (Red)	1	Joystick / Spout Rotate Front
4	9005982	Hose Marker Sleeve - Hydraulic Pressure (Red)	1	Joystick / Spout Rotate Back
5	9006527	JIC Tube Reducer 9/16"-18 UNF M x 9/16"-UNF F	1	
6	901568	Elbow, 90° Extra Long 3/4"-16 JIC x 3/4"-16 O-Ring M	1	
7	91257	Large Flange Hex Nut, 5/16"-18UNC Gr.5	3	
8	91383	Male Tip Coupling, 3/4"-16	2	
9	98508	Adapter 3/4"-16 O-Ring M x 3/4"-16 O-Ring M	2	
10	9006994	Check Line Valve 145 PSI	1	
11	9390-042	Capscrew, 5/16"-18UNC x 4" Gr.5	3	
12	9874	Elbow, 90° 9/16"-18 JIC M x 3/4"-16 OR ADJ M	1	
13	272606B	Valve Cover Plate	1	Also Order Item #15
14	9005403	120 Micron Hydraulic Filter	1	
15	9008564	Decal, CAUTION (Valve Block)	1	Located Inside Cover Plate #13
16	9003848	Velcro Hose Wrap, 2" I.D. x 127"	1	

EOH Spout Rotate Option and Tilt Hydraulic Components

Please visit www.unverferth.com/parts/ for the most current parts listing.

OPTIONAL SPOUT ROTATE

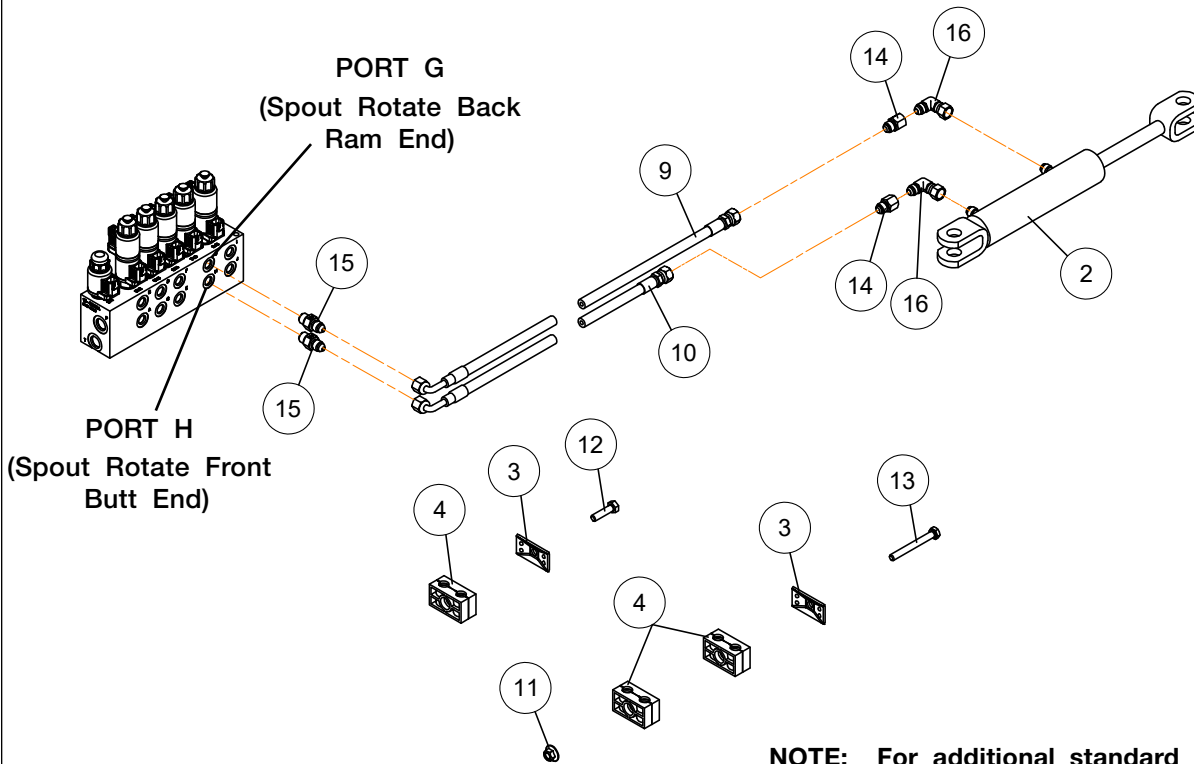

NOTE: For additional standard spout parts listing, refer to "Downspout Components" in this section.

SPOUT TILT

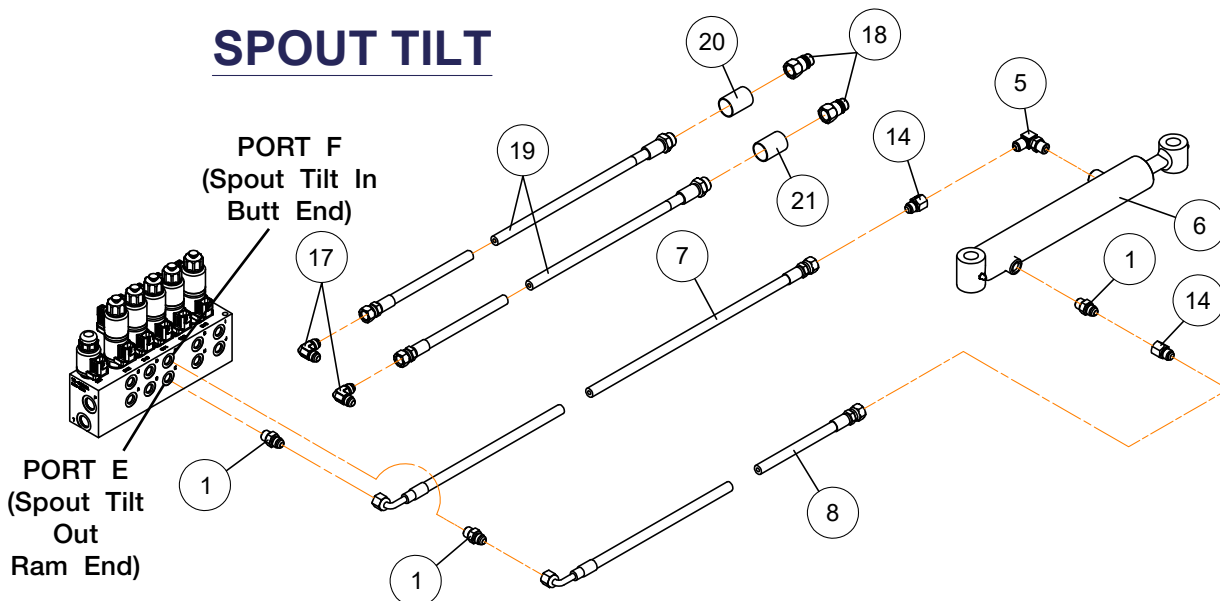

EOH Spout Rotate Option and Tilt Hydraulic Components

Please visit www.unverferth.com/parts/ for the most current parts listing.

ITEM	PART NO.	DESCRIPTION	QTY.	NOTES
1	9001495	Adapter, 9/16"-18 JIC Male x 9/16"-18 OR Male	3	Optional EOH Spout Tilt
			1	Standard Spout Tilt
2	9007124	Hydraulic Cylinder, 1 1/2" x 3" - 3000 PSI	1	Optional EOH Spout Rotate
	9005419	Seal Kit	-	
3	9003814	Clamp Top Plate, 1/4" x 1 1/8" x 2 1/16"	2	
4	9003816	Clamp, Polypropylene	3	
5	9004379	Elbow, 90° 9/16"-18 JIC Male x 9/16"-18 OR ADJ Male	1	
6	9005135	Hydraulic Cylinder, 1 1/2" x 8" - 3000 PSI	1	
	9005419	Seal Kit	-	
7	9006579	Hydraulic Hose, 1/4" x 321" - 3000 PSI	1	
8	9006580	Hydraulic Hose, 1/4" x 312" - 3000 PSI	1	
9	9006581	Hydraulic Hose, 1/4" x 295" - 3000 PSI	1	Optional EOH Spout Rotate
10	9006582	Hydraulic Hose, 1/4" x 290" - 3000 PSI	1	
11	91257	Large Flange Hex Nut, 5/16"-18UNC Grade 5	1	
12	9390-031	Capscrew, 5/16"-18UNC x 1 1/4 " Grade 5	1	
13	9390-037	Capscrew, 5/16"-18UNC x 2 3/4" Grade 5	1	
14	95193	Adapter, 9/16"-18 JIC Female x 9/16"-18 JIC Male	4	
15	98435	Adapter, 9/16"-18 JIC Male x 9/16"-18 OR Male	2	Optional EOH Spout Rotate (Includes 0.030" Red Restrictor)
16	9876	90° Elbow, 9/16"-18 JIC Male x 9/16"-18 JIC Female	2	Optional EOH Spout Rotate
17	9897	Elbow, 90° 9/16"-18 JIC Male x 9/16"-18 JIC Male	2	
18	91383	Male Tip Coupling, 3/4"-16	2	
19	9005574	Hydraulic Hose, 1/4" x 208" - 3000 PSI	2	
20	9003999	Hose Marker Sleeve - Spout Out (Yellow)	1	
21	9004000	Hose Marker Sleeve - Spout In (Yellow)	1	

Auger Pivot Hydraulic Components

Please visit www.unverferth.com/parts/ for the most current parts listing.

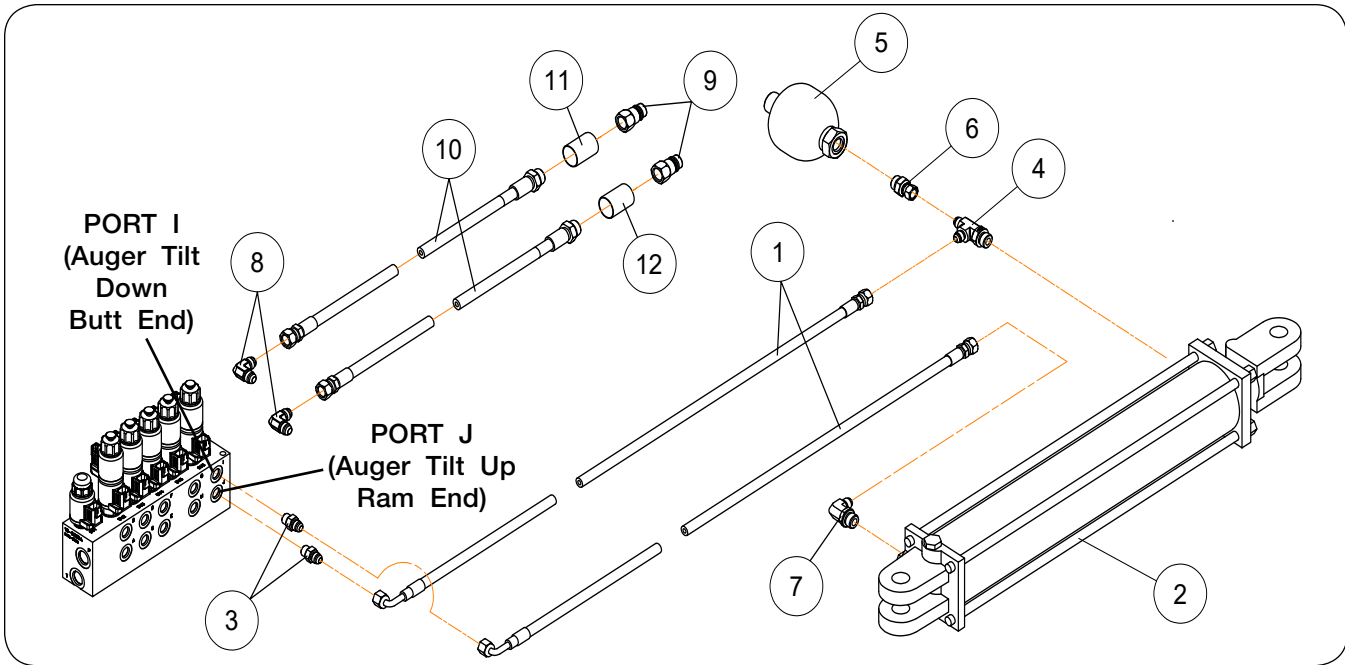

ITEM	PART NO.	DESCRIPTION	QTY.	NOTES
1	9000925	Hydraulic Hose, 1/4" x 78" - 3000 PSI	2	
2	9000933	Hydraulic Cylinder, 3 1/2" x 20" - 3000 PSI	1	
	9001081	Seal Kit	-	
3	9001495	Adapter, 9/16"-18 JIC M x 9/16"-18 OR M	2	Optional EOH (Includes 0.030" Red Restrictor)
4	9002155	Tee, 9/16"-18 JIC M x 3/4"-16 OR ADJ M	1	
5	9002719	Accumulator - 1800 PSI	1	
6	9002720	Adapter, 3/4"-16 OR M x 9/16"-18 JIC F	1	
7	9874	Elbow, 90° 9/16"-18 JIC M x 3/4"-16 OR ADJ M	1	
8	9897	Elbow, 90° 9/16"-18 JIC M x 9/16"-18 JIC M	2	
9	91383	Male Tip Coupling, 3/4"-16	2	
10	9005574	Hydraulic Hose, 1/4" x 208" - 3000 PSI	2	
11	9004001	Hose Marker Sleeve - Auger Pivot Up (Orange)	1	
12	9004002	Hose Marker Sleeve - Auger Pivot Down (Orange)	1	

Auger Fold Hydraulic Components

Please visit www.unverferth.com/parts/ for the most current parts listing.

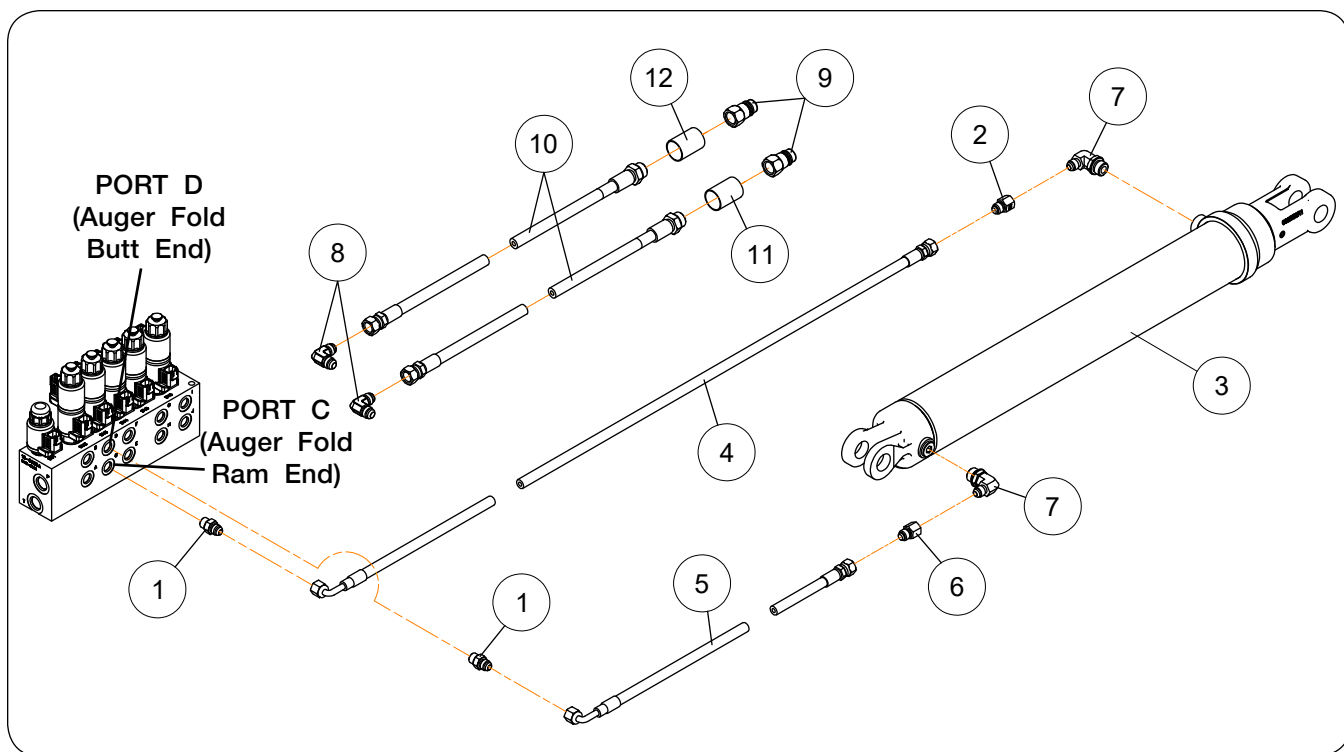

ITEM	PART NO.	DESCRIPTION	QTY.	NOTES
1	9001495	Adapter, 9/16"-18 JIC Male x 9/16"-18 OR Male	2	Optional EOH (Includes 0.030" Red Restrictor)
2	9002199	Reducer, 9/16"-18 JIC Female x 9/16"-18 JIC Male	1	0.060" Yellow Restrictor
3	9004730	Hydraulic Cylinder, 3" x 22" - 3000 PSI	1	
	9003772	Seal Kit	-	
4	9006608	Hydraulic Hose, 1/4" x 84" - 3000 PSI	1	
5	93594	Hydraulic Hose, 1/4" x 59" - 3000 PSI	1	
6	9003303	Adapter, 9/16"-18 JIC Female x 9/16"-18 JIC Male	1	0.045" Blue Restrictor
7	9874	Elbow, 90° 9/16"-18 JIC Male x 3/4"-16 OR ADJ Male	2	
8	9897	Elbow, 90° 9/16"-18 JIC Male x 9/16"-18 JIC Male	2	
9	91383	Male Tip Coupling, 3/4"-16	2	
10	9005574	Hydraulic Hose, 1/4" x 208" - 3000 PSI	2	
11	9003997	Hose Marker Sleeve - Auger Raise (Green)	1	
12	9003998	Hose Marker Sleeve - Auger Lower (Green)	1	

Flow Door Circuit Hydraulic Components

Please visit www.unverferth.com/parts/ for the most current parts listing.

Flow Door Cylinder

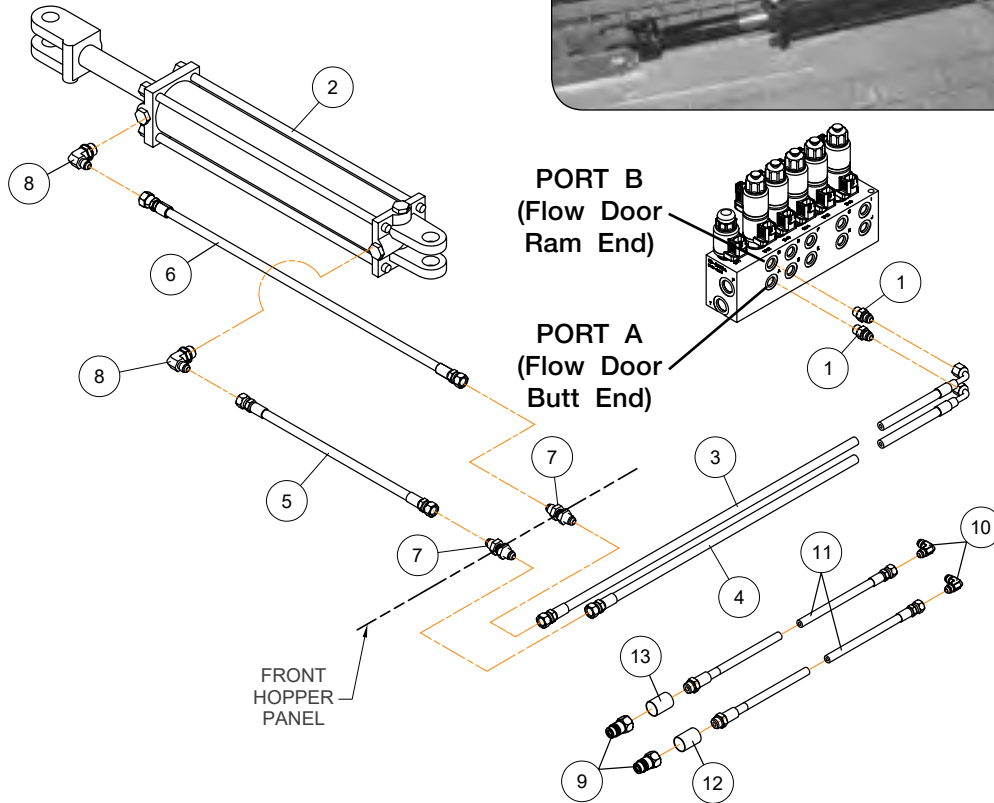

Flow Door Circuit Hydraulic Components

Please visit www.unverferth.com/parts/ for the most current parts listing.

ITEM	PART NO.	DESCRIPTION	QTY.	NOTES
1	9001495	Adapter, 9/16"-18 JIC Male x 9/16"-18 OR Male	2	Optional EOH (Includes 0.030" Red Restrictor)
2	9002575	Hydraulic Cylinder, 3" x 16" - 3000 PSI	1	
	9003772	Seal Kit	-	
3	9004442	Hydraulic Hose, 1/4" x 54" - 3000 PSI	1	
4	9006607	Hydraulic Hose, 1/4" x 50" - 3000 PSI	1	
5	93472	Hydraulic Hose, 1/4" x 16" - 3000 PSI	1	
6	9002888	Hydraulic Hose, 1/4" x 27" - 3000 PSI	1	
7	95192	Bulkhead Union, 9/16"-18 JIC Male x 9/16"-18 JIC Male	2	
8	9874	Elbow, 90° 9/16"-18 JIC Male x 3/4"-16 OR ADJ Male	2	
9	91383	Male Tip Coupling, 3/4"-16	2	
10	9897	Elbow, 90° 9/16"-18 JIC Male x 9/16"-18 JIC Male	2	
11	9005574	Hydraulic Hose, 1/4" x 208" - 3000 PSI	2	
12	9003995	Hose Marker Sleeve - Flow Door Open (Red)	1	
13	9003996	Hose Marker Sleeve - Flow Door Close (Red)	1	

Cylinders

Please visit www.unverferth.com/parts/ for the most current parts listing.

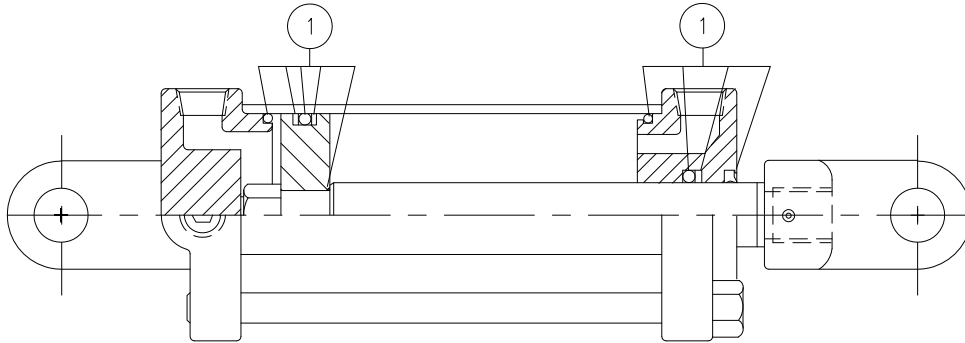

Auger Fold Cylinder - 3" x 22"

ITEM	PART NO.	DESCRIPTION	QTY.	NOTES
	9004730	Cylinder, Complete	1	
1	9003772	Seal Kit	1	

Auger Flow Door Cylinder - 3" x 16"

ITEM	PART NO.	DESCRIPTION	QTY.	NOTES
	9002575	Cylinder, Complete	1	
1	9003772	Seal Kit	1	

Auger Tilt Cylinder - 3 1/2" x 20"

ITEM	PART NO.	DESCRIPTION	QTY.	NOTES
	9000933	Cylinder, Complete	1	
1	9001081	Seal Kit	1	

Auger Spout Tilt Cylinder - 1 1/2" x 8"

ITEM	PART NO.	DESCRIPTION	QTY.	NOTES
	9005135	Cylinder, Complete	1	#6 9/16"-18 O-Ring Ports (3000 PSI)
1	9005419	Seal Kit	1	

Cylinders (continued)

Please visit www.unverferth.com/parts/ for the most current parts listing.

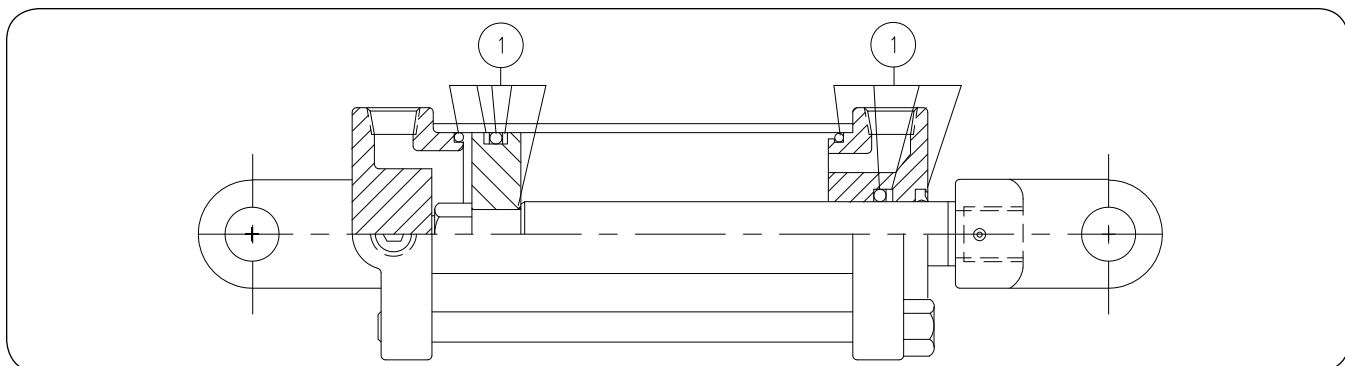

Optional Spout Rotate Cylinder - 1 1/2" x 3"

ITEM	PART NO.	DESCRIPTION	QTY.	NOTES
	9007124	Cylinder, Complete	1	
1	9005419	Seal Kit	1	

Optional Jack Cylinder - 3 1/2" x 8"

ITEM	PART NO.	DESCRIPTION	QTY.	NOTES
	9009047	Cylinder, Complete	1	
1	9007880	Seal Kit	1	

Hopper Rear Electrical Components

Please visit www.unverferth.com/parts/ for the most current parts listing.

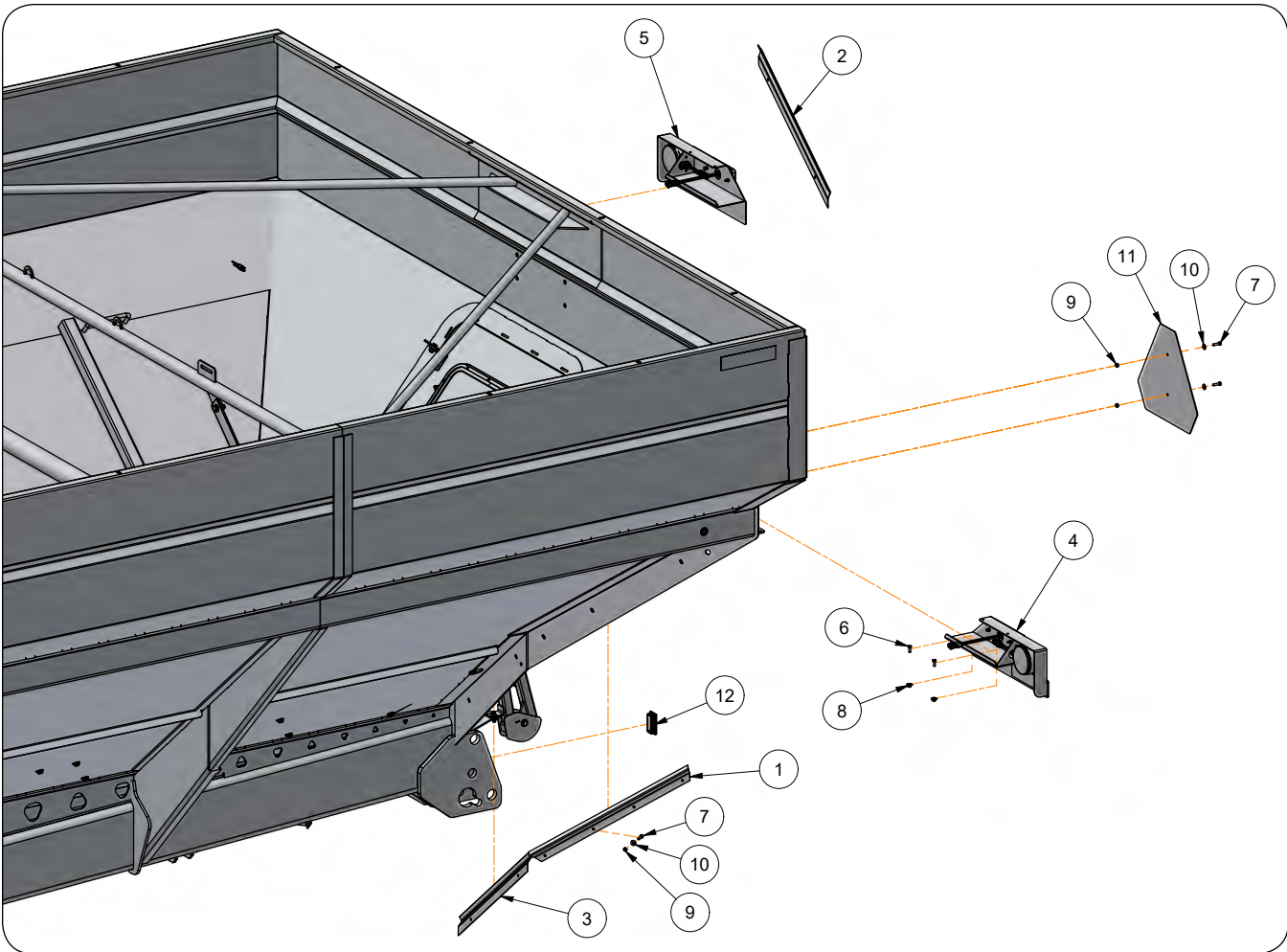

Hopper Rear Electrical Components

Please visit www.unverferth.com/parts/ for the most current parts listing.

ITEM	PART NO.	DESCRIPTION	QTY	NOTES
1	282305G	Upper Harness Cover =Green=	2	
	282305R	Upper Harness Cover =Red=		
2	282308G	Harness Cover Plate RH =Green=	1	
	282308R	Harness Cover Plate RH =Red=		
3	282309G	Harness Cover Plate LH =Green=	1	
	282309R	Harness Cover Plate LH =Red=		
4	284358B	Lamp Assembly LH =Black=	1	
5	284359B	Lamp Assembly RH =Black=	1	
6	9390-003	Capscrew 1/4"-20UNC x 3/4" Grade 5	4	
7	9390-005	Capscrew 1/4"-20UNC x 1" Grade 5	12	
8	97189	Large Flange Hex Nut 1/4"-20UNC Grade 5	4	
9	9936	Locknut 1/4"-20UNC	12	
10	9405-064	Flat Washer 1/4"	12	
11	TA510514	SMV Emblem	1	
12	9009931	Plug, 1 1/2" x 3"	2	

Electrical Components

Please visit www.unverferth.com/parts/ for the most current parts listing.

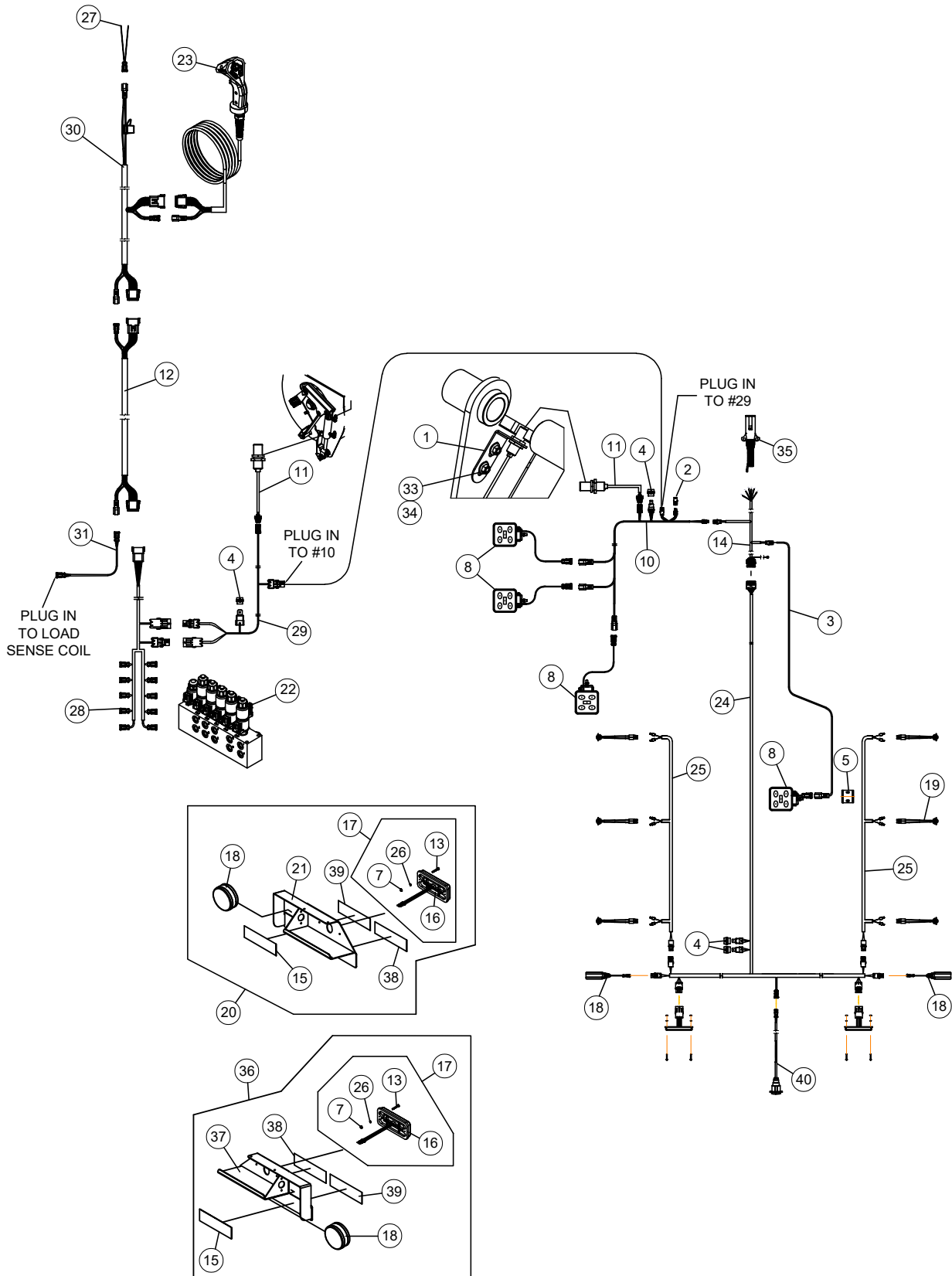

Electrical Components

Please visit www.unverferth.com/parts/ for the most current parts listing.

ITEM	PART NO.	DESCRIPTION	QTY	NOTES
1	272645B	Switch Plate Bracket =Black=	1	
2	252386	Plug Assembly, 2 Pin Shroud	1	
3	9008969	Wiring Harness - 226" (w/2-Pin Connectors)	1	For SN B41030100 & Higher
	9008502		1	For SN B41030099 & Lower
4	9005618	Relay - 12VDC	4	
5	271574B	Lamp Mount Plate =Black=	1	
7	9830-016	Hex Nut, #10-32 Grade 2	4	
8	9008957	Work Light (LED) (w/2-Pin Connector)	4	For SN B41030100 & Higher
	9007186		3	For SN B41030099 & Lower
10	9008956	Switch Wiring Harness (w/2-Pin Connector Ends)	1	For SN B41030100 & Higher
	9008107		1	For SN B41030099 & Lower
11	9007223	Proximity Switch	2	
12	9008252	Joystick Controller Extension Harness	1	
13	903172-350	Phillips Pan Head Screw, #10-32UNF x 1-1/4"	4	
14	9008501	Front Harness - 296" (w/2 Pin Shroud Connectors)	1	
15	9003127	Reflector 2" x 9" =Amber=	2	
16	9006282	LED Lamp - Red	2	
17	232170	LED Lamp - Red - Replacement Kit	2	Includes Items 7, 13, 16 & 26
18	9005142	LED Lamp - Amber	2	
19	9006107	Micro Dot, LED Amber Light	6	
20	284359B	Lamp Assembly Right-Hand =Black=	1	
21	284371B	Lamp Mount Weldment Right-Hand =Black=	1	
22	293416	EOH Block Assembly - 5 Spool Replacement Kit	1	
23	9008265	L-Series Control Grip - 5 Function	1	
24	9009586	Rear Harness	1	For SN B44630100 & Higher
	9006480		1	For SN B44630099 & Lower
25	9006520	Clearance Harness	2	
26	9404-013	Lock Washer, #10	4	
27	9006907	Power Harness, 2-Pin	1	
28	9007290	"T" Main Wiring Harness - 189"	1	
29	9007286	Wiring Harness - 205" EOH for Proximity Switch	1	
30	9008251	Harness - Joystick Power	1	
31	9007266	Wire Harness, 218 5/16" (2 Pin Diverter)	1	
33	91262	Large Flange Screw, 3/8"-16UNC x 1" Grade 5	2	
34	91263	Large Flange Nut, 3/8"-16UNC Grade 5	2	
35	92450	7-Way Plug	1	
36	284358B	Lamp Assembly Left-Hand =Black=	1	
37	284370B	Lamp Mount Weldment Left-Hand =Black=	1	
38	9003125	Decal, 2" x 9" =Fluorescent=	2	
39	9003126	Reflector 2" x 9" =Red=	2	
40	9009843	7-Blade Connector	1	Optional Rear Hitch For SN B44630100 & Higher

End Caps, Tarp Bows & Mounting Brackets

Please visit www.unverferth.com/parts/ for the most current parts listing.

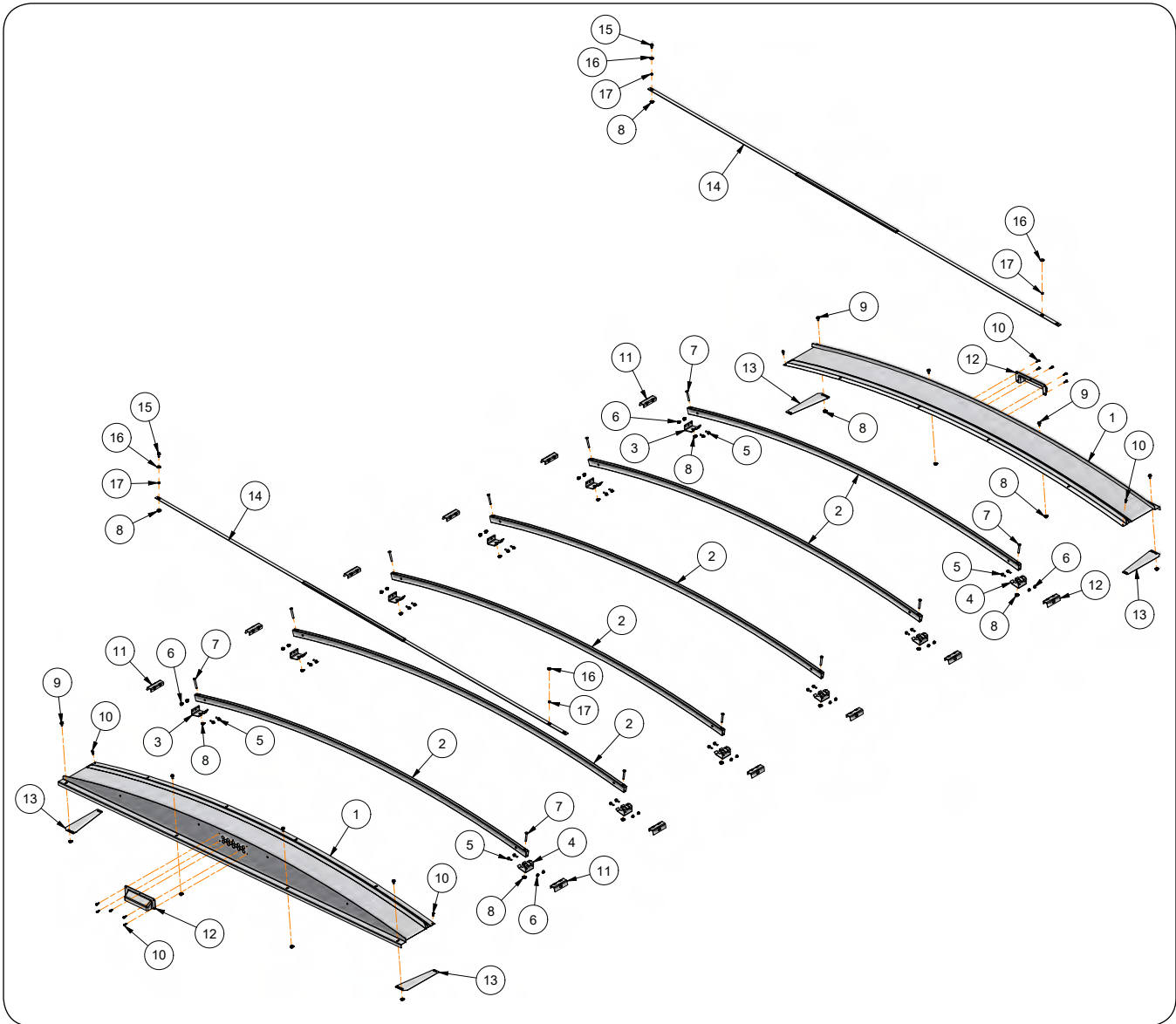

End Caps, Tarp Bows & Mounting Brackets

Please visit www.unverferth.com/parts/ for the most current parts listing.

ITEM	PART NO.	DESCRIPTION	QTY	NOTES
1	295997B	End Cap Weldment =Black=	2	296750B End Cap Service Kit Includes Items 1, 10, 12
2	283424B	Tarp Bow Weldment =Black=	6	
3	283425B	Tarp Bow Bracket =Black= (Right-Hand Side)	6	
4	283427B	Tarp Bow Bracket =Black= (Left-Hand Side)	6	
5	97604	Screw/Large Flange 5/16"-18UNC x 1"	24	
6	91257	Flange Nut 5/16"-18UNC	24	
7	902703-046	Socket Flat Countersunk Capscrew, 3/8"-16UNC x 3"	12	
8	91263	Nut/Large Flange 3/8"-16UNC Grade 5	22	
9	95585	Capscrew/Large Flange 3/8"-16UNC x 3/4" Grade 5	8	
10	9512	Screw/Self Drilling 1/4"-14 x 1	14	
11	294660B	Doubler Plate =Black=	12	
12	9009504	Endcap Vent Cover	2	
13	295668B	Sideboard Cover Plate =Black=	4	
14	9008948	Hurricane Strap For 12 FT Wide Hopper	2	
15	96972	Screw/Self Tapping 3/8"-16UNC x 1"	2	
16	9008972	Flat Washer, 3/8" Aluminum	4	
17	9008949	Tarp Strap Spacer Bushing	4	

Weather Guard Tarp

Please visit www.unverferth.com/parts/ for the most current parts listing.

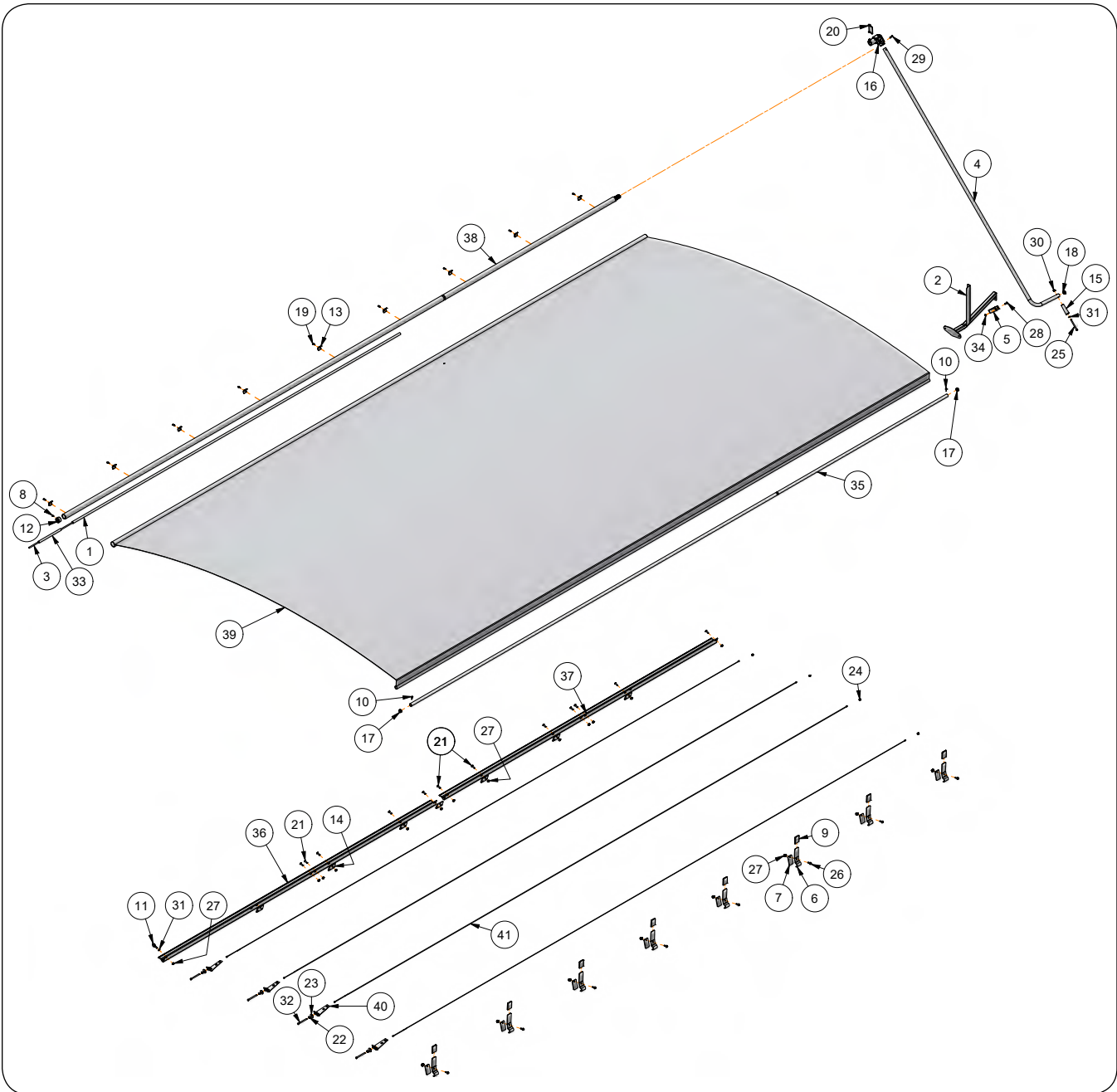

Weather Guard Tarp

Please visit www.unverferth.com/parts/ for the most current parts listing.

ITEM	PART NO.	DESCRIPTION	QTY	NOTES
1	221668	Pipe - 180"	1	
2	296423B	Handle Bracket Weldment =Black=	1	For SN B44630100 & Higher
	221696B			For SN B44630099 & Lower
3	221722	Bungee 3/8" Dia. x 204"	1	
4	221749	Tarp Handle Weldment	1	
5	221770B	Handle Retainer Weldment =Black=	1	
6	291661B	Tarp Stop Plate =Black=	8	
7	295183B	Tarp Stop Spacer Plate =Black=	8	
8	9001396	Pan Head Screw #10-16 x 1/2"	1	
9	9003078	Cap - Plastic (2" x 3")	8	
10	9003378	Rivet/Pop 3/16"	2	
11	9004548	Eye Bolt 3/8"-16UNC x 1 3/4"	1	
12	9004947	Plug 2"	1	
13	9004949	U-Clamp	9	
14	295259B	Tarp Spacer Plate =Black=	7	
15	9004969	Handle	1	
16	9004977	U-Joint w/ 1 3/8"-21 Spline	1	
17	9005088	Plug 1 1/8"	2	
18	9005089	Plug 1 1/4"	1	
19	9005197	Screw/Self Drilling #10-16 x 3/4" Pan Head	9	
20	9005305	Lynch Pin 3/8" x 3"	1	
21	9009089	Torx Head Machine Screw 3/8-16UNC x 1 1/4 Grade 5	12	
22	9005688	Star Washer	4	
23	9005696	Fender Washer	4	
24	9005727	Plug 7/16"	4	
25	903172-450	Phillips Pan Head Screw 3/8"-16UNC x 4 1/2"	1	
26	9003259	Flange Screw 3/8"-16UNC x 1 1/4" Grade 5	8	
27	91263	Nut/Large Flange 3/8"-16UNC Grade 5	21	
28	9390-055	Capscrew 3/8"-16UNC x 1" Grade 5	1	
29	9392-180	Roll Pin 3/8" Dia. x 2"	1	
30	9398-012	Elastic Stop Nut 3/8"-16UNC	1	
31	9405-074	Flat Washer 3/8"	3	
32	TA0-907131-0	Capscrew 3/8"-16UNC x 4 1/2" (Full Threaded)	4	
33	TA806225	Hose 1/2" EPDM	1	
34	9928	Locknut 3/8-16UNC	1	
35	221615	Fixed Tube Weldment	1	
36	296834	Plate - Latch 149 1/2" (Front)	1	
37	296835	Plate - Latch 149 1/2" (Rear)	1	
38	221789	Roll Tube Weldment	1	
39	9005046	Tarp 166" x 293"	1	
	9005581	Tarp Patch Kit	-	
40	281712B	Bracket & U-Nut Assembly =Black=	4	
41	9005677	Cable Assembly 282"	4	

Hydraulic Jack - Kit #296289B (Optional)

Please visit www.unverferth.com/parts/ for the most current parts listing.

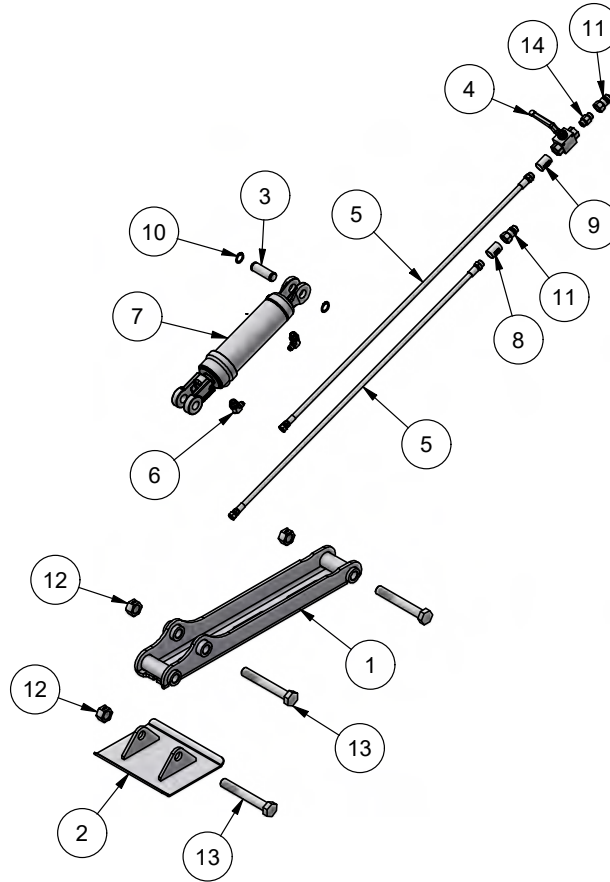

ITEM	PART NO.	DESCRIPTION	QTY	NOTES
1	271712B	Jack Weldment =Black=	1	
2	271723B	Jack Foot Weldment =Black=	1	
3	272587	Pin, 1" Dia. x 3 1/8"	1	
4	9005426	High Pressure Ball Valve	1	
5	9006068	Hydraulic Hose, 1/4" x 92" - 3000 PSI	2	
6	9006173	Elbow, 90°	2	
7	9009047	Hydraulic Cylinder, 3 1/2" x 8" - 3000 PSI	1	
8	9006651	Sleeve Hose Marker - Raise Jack	1	
9	9006652	Sleeve Hose Marker - Lower Jack	1	
10	91192	Retaining Ring, 1"	2	
11	91383	Male Tip Coupling	2	
12	92199	Center Locknut, 1"-8UNC	3	
13	9390-197	Capscrew, 1"-8UNC x 7" Grade 5	3	
14	98508	Adapter, 3/4"-16 OR Male x 3/4"-16 OR Male	1	

**Rear Drop Hitch Components (Optional)
For SN B44630100 and Higher**

Please visit www.unverferth.com/parts/ for the most current parts listing.

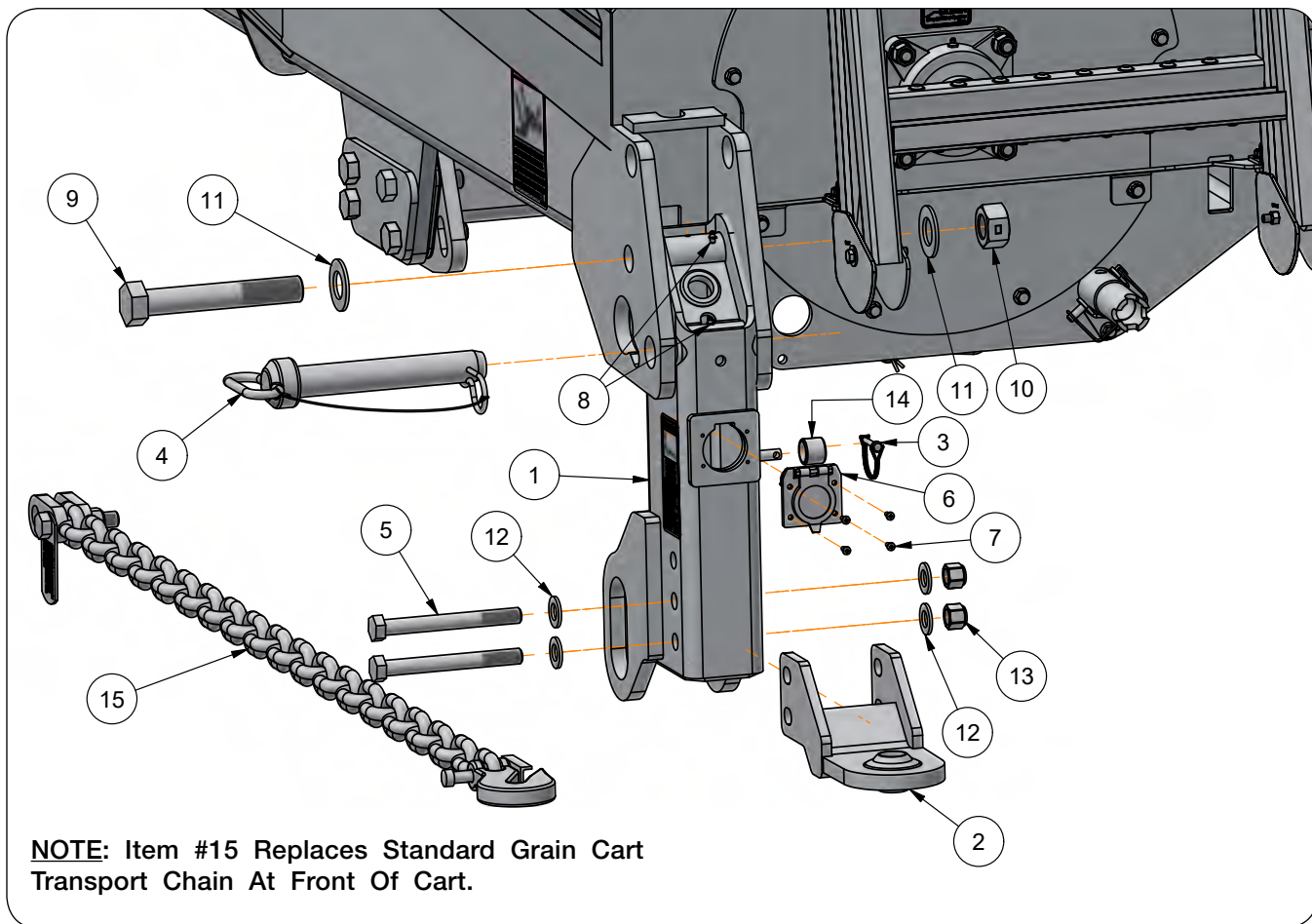

ITEM	PART NO.	DESCRIPTION	QTY	NOTES
	296960B	Rear Drop Hitch Kit (Black)	-	Includes Items 1-15. See "Front End Components" For Additional Details.
1	297128B	Rear Drop Hitch Assembly (Black)	1	Includes Decal, WARNING (Towing Capacity) 9009646
2	295978B	Rear Hitch Weldment =Black=	1	
3	9000936	Lynch Pin	1	
4	9009656	Pivot Pin	1	
5	9390-159	Capscrew 3/4"-10UNC x 7" Grade 5	2	
6	9009843	7-Blade Connector	1	
7	903172-133	Phillips Head Screw #10-24 x 1/2"	4	
8	91160	Grease Zerk	2	
9	9390-225	Capscrew 1 1/4"-7UNC x 8" Grade 5	1	
10	93476	Lock Nut 1 1/4"-7UNC Grade 5	1	
11	9405-128	Flat Washer 1 1/4" SAE	2	
12	9405-104	Flat Washer 3/4" SAE	4	
13	9398-021	Lock Nut 3/4"-10UNC	2	
14	91268	Tension Bushing	1	
15	PF1238-19	Transport Chain #61,000	1	Replaces Standard Grain Cart Transport Chain If Equipped With Optional Rear Hitch

Video System (Optional)

Please visit www.unverferth.com/parts/ for the most current parts listing.

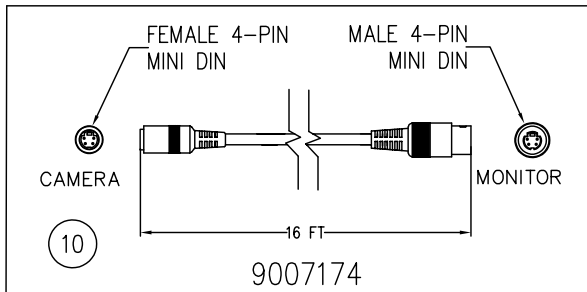
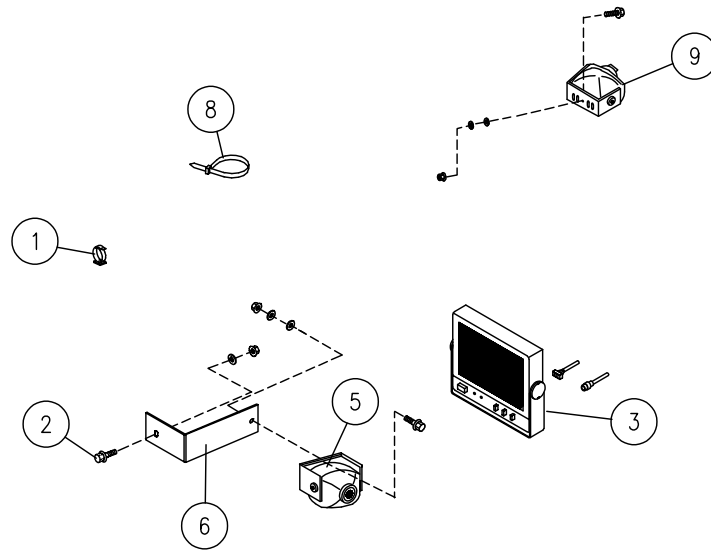

9004510 CABLE W/FUSE WIRES

- Red -- Key Switched Power
- Black -- Ground
- Green -- **NOT USED**
- White -- **NOT USED**

IMPORTANT ! Do not operate Video System below 15° F.

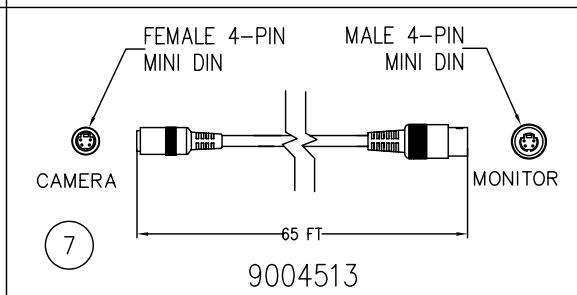
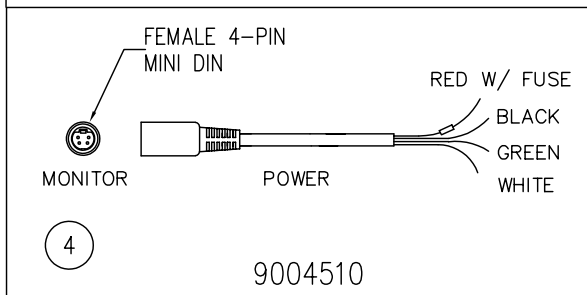

ITEM	PART NO.	DESCRIPTION	QTY	NOTES
	265770	Video System Kit for Front View	1	Includes Items 1-8 and own Instruction Sheet
	9004506	Additional Camera for Rear View	1	Includes Items 6 & 7
1	TAAU14007	Snap Clip, Adhesive	10	
2	9512	Self-Drilling Screw 1/4"-14 x 1	10	
3	9006273	Monitor, 7" LCD/LED	1	
4	9004510	Cable w/Fuse	1	
5	9006274	Camera	1	
6	265771B	Bracket	1	
7	9004513	Cable, 65'	1	
8	9000107	Cable Tie	AR	
9	9004506	Camera Kit for Rear View with 65' Cable	1	
10	9007174	Camera Cable, 16 ft.	1	

Notes

Please visit www.unverferth.com/parts/ for the most current parts listing.



Unverferth.
Manufacturing Company, Inc.

www.unverferth.com